



SAF7118

Multistandard video decoder with adaptive comb filter and component video input

Rev. 03 — 16 February 2006

Product data sheet

1. General description

The SAF7118 is a video capture device for applications at the image port of Video Graphics Array (VGA) controllers.

Philips X-VIP is a new multistandard comb filter video decoder chip with additional component processing, providing high quality, optionally scaled and video.

The SAF7118 is a combination of a four-channel analog preprocessing circuit including source selection, anti-aliasing filter and Analog-to-Digital Converter (ADC) with succeeding decimation filters from 27 MHz to 13.5 MHz data rate. Each preprocessing channel comes with an automatic clamp and gain control. The SAF7118 combines a Clock Generation Circuit (CGC), a digital multistandard decoder containing two-dimensional chrominance/luminance separation by an adaptive comb filter and a high performance scaler, including variable horizontal and vertical up and downscaling and a brightness, contrast and saturation control circuit.

It is a highly integrated circuit for desktop video and similar applications. The decoder is based on the principle of line-locked clock decoding and is able to decode the color of PAL, SECAM and NTSC signals into ITU 601 compatible color component values. The SAF7118 accepts CVBS or S-video (Y/C) as analog inputs from TV or VCR sources, including weak and distorted signals as well as baseband component signals Y-P_B-P_R or RGB. An expansion port (X port) for digital video (bidirectional half duplex, D1 compatible) is also supported to connect to MPEG or a video phone codec. At the so called image port (I port) the SAF7118 supports 8-bit or 16-bit wide output data with auxiliary reference data for interfacing to VGA controllers.

The target application for the SAF7118 is to capture and scale video images, to be provided as a digital video stream through the image port of a VGA controller, for capture to system memory, or just to provide digital baseband video to any picture improvement processing.

The SAF7118 also provides a means for capturing the serially coded data in the Vertical Blanking Interval (VBI) data. Two principal functions are available:

1. To capture raw video samples, after interpolation to the required output data rate, via the scaler
2. A versatile data slicer (data recovery) unit

The SAF7118 also incorporates field-locked audio clock generation. This function ensures that there is always the same number of audio samples associated with a field, or a set of fields. This prevents the loss of synchronization between video and audio during capture or playback.

PHILIPS

All of the ADCs may be used to digitize a VSB signal for subsequent decoding; a dedicated output port and a selectable VSB clock input is provided.

The circuit is I²C-bus controlled (full write/read capability for all programming registers, bit rate up to 400 kbit/s).

2. Features

2.1 Video acquisition/clock

- Up to sixteen analog CVBS, split as desired (all of the CVBS inputs optionally can be used to convert e.g. Vestigial Side Band (VSB) signals)
- Up to eight analog Y + C inputs, split as desired
- Up to four analog component inputs, with embedded or separate sync, split as desired
- Four on-chip anti-aliasing filters in front of the ADCs
- Automatic Clamp Control (ACC) for CVBS, Y and C (or VSB) and component signals
- Switchable white peak control
- Four 9-bit low noise CMOS ADCs running at twice the oversampling rate (27 MHz)
- Fully programmable static gain or Automatic Gain Control (AGC), matching to the particular signal properties
- On-chip line-locked clock generation in accordance with "ITU 601"
- Requires only one crystal (32.11 MHz or 24.576 MHz) for all standards
- Horizontal and vertical sync detection

2.2 Video decoder

- Digital Phase-Locked Loop (PLL) for synchronization and clock generation from all standards and non-standard video sources e.g. consumer grade VTR
- Automatic detection of any supported color standard
- Luminance and chrominance signal processing for PAL B, G, D, H, I and N, combination PAL N, PAL M, NTSC M, NTSC-Japan, NTSC 4.43 and SECAM
- Adaptive 2/4-line comb filter for two dimensional chrominance/luminance separation, also with VTR signals
 - ◆ Increased luminance and chrominance bandwidth for all PAL and NTSC standards
 - ◆ Reduced cross color and cross luminance artefacts
- PAL delay line for correcting PAL phase errors
- Brightness Contrast Saturation (BCS) adjustment, separately for composite and baseband signals
- User programmable sharpness control
- Detection of copy-protected signals according to the Macrovision standard, indicating level of protection
- Independent gain and offset adjustment for raw data path

2.3 Component video processing

- RGB component inputs
- Y-P_B-P_R component inputs
- Fast blanking between CVBS and synchronous component inputs
- Digital RGB to Y-C_B-C_R matrix

2.4 Video scaler

- Horizontal and vertical downscaling and upscaling to randomly sized windows
- Horizontal and vertical scaling range: variable zoom to $\frac{1}{64}$ (icon) (it should be noted that the H and V zoom are restricted by the transfer data rates)
- Anti-alias and accumulating filter for horizontal scaling
- Vertical scaling with linear phase interpolation and accumulating filter for anti-aliasing (6-bit phase accuracy)
- Horizontal phase correct up and downscaling for improved signal quality of scaled data, especially for compression and video phone applications, with 6-bit phase accuracy (1.2 ns step width)
- Two independent programming sets for scaler part, to define two 'ranges' per field or sequences over frames
- Fieldwise switching between decoder part and expansion port (X port) input
- Brightness, contrast and saturation controls for scaled outputs

2.5 VBI data decoder and slicer

- Versatile VBI data decoder, slicer, clock regeneration and byte synchronization e.g. for World Standard Teletext (WST), North American Broadcast Text System (NABTS), closed caption, Wide Screen Signalling (WSS), etc.

2.6 Audio clock generation

- Generation of a field-locked audio master clock to support a constant number of audio clocks per video field
- Generation of an audio serial and left/right (channel) clock signal

2.7 Digital I/O interfaces

- Real-time signal port (R port), inclusive continuous line-locked reference clock and real-time status information supporting RTC level 3.1 (refer to document "*RTC Functional Specification*" for details)
- Bidirectional expansion port (X port) with half duplex functionality (D1), 8-bit Y-C_B-C_R:
 - ◆ Output from decoder part, real-time and unscaled
 - ◆ Input to scaler part, e.g. video from MPEG decoder (extension to 16-bit possible)
- Video image port (I port) configurable for 8-bit data (extension to 16-bit possible) in master mode (own clock), or slave mode (external clock), with auxiliary timing and handshake signals
- Discontinuous data streams supported
- 32-word × 4-byte FIFO register for video output data
- 28-word × 4-byte FIFO register for decoded VBI data output
- Scaled 4 : 2 : 2, 4 : 1 : 1, 4 : 2 : 0, 4 : 1 : 0 Y-C_B-C_R output

- Scaled 8-bit luminance only and raw CVBS data output
- Sliced, decoded VBI data output

2.8 Miscellaneous

- Power-on control
- 5 V tolerant digital inputs and I/O ports
- Software controlled power saving standby modes supported
- Programming via serial I²C-bus, full read back ability by an external controller, bit rate up to 400 kbit/s
- Boundary scan test circuit complies with the "IEEE Std. 1149.b1 - 1994".

3. Applications

- PC-video capture and editing
- Personal video recorders (time shifting)
- Cable, terrestrial, and satellite set-top boxes
- Internet terminals
- Flat-panel monitors
- DVD recordable players
- AV-ready hard-disk drivers
- Digital televisions/scan conversion
- Video surveillance/security
- Video editing/post production
- Video phones
- Video projectors
- Digital VCRs

4. Quick reference data

Table 1: Quick reference data

Symbol	Parameter	Conditions	Min	Typ	Max	Unit
V _{DDD}	digital supply voltage		3.0	3.3	3.6	V
V _{DDA}	analog supply voltage		3.1	3.3	3.5	V
T _{amb}	ambient temperature		-40	-	+85	°C
P _{tot(A+D)}	total power dissipation analog and digital part	component mode	[1] -	1105	1350	mW

[1] 8-bit image port output mode, expansion port is 3-stated.

5. Ordering information

Table 2: Ordering information

Type number	Package		
	Name	Description	Version
SAF7118EH	HBGA156	plastic thermal enhanced ball grid array package; 156 balls; body 15 × 15 × 1.15 mm	SOT807-1
SAF7118H	QFP160	plastic quad flat package; 160 leads (lead length 1.6 mm); body 28 × 28 × 3.4 mm; high stand-off height	SOT322-2

6. Block diagram

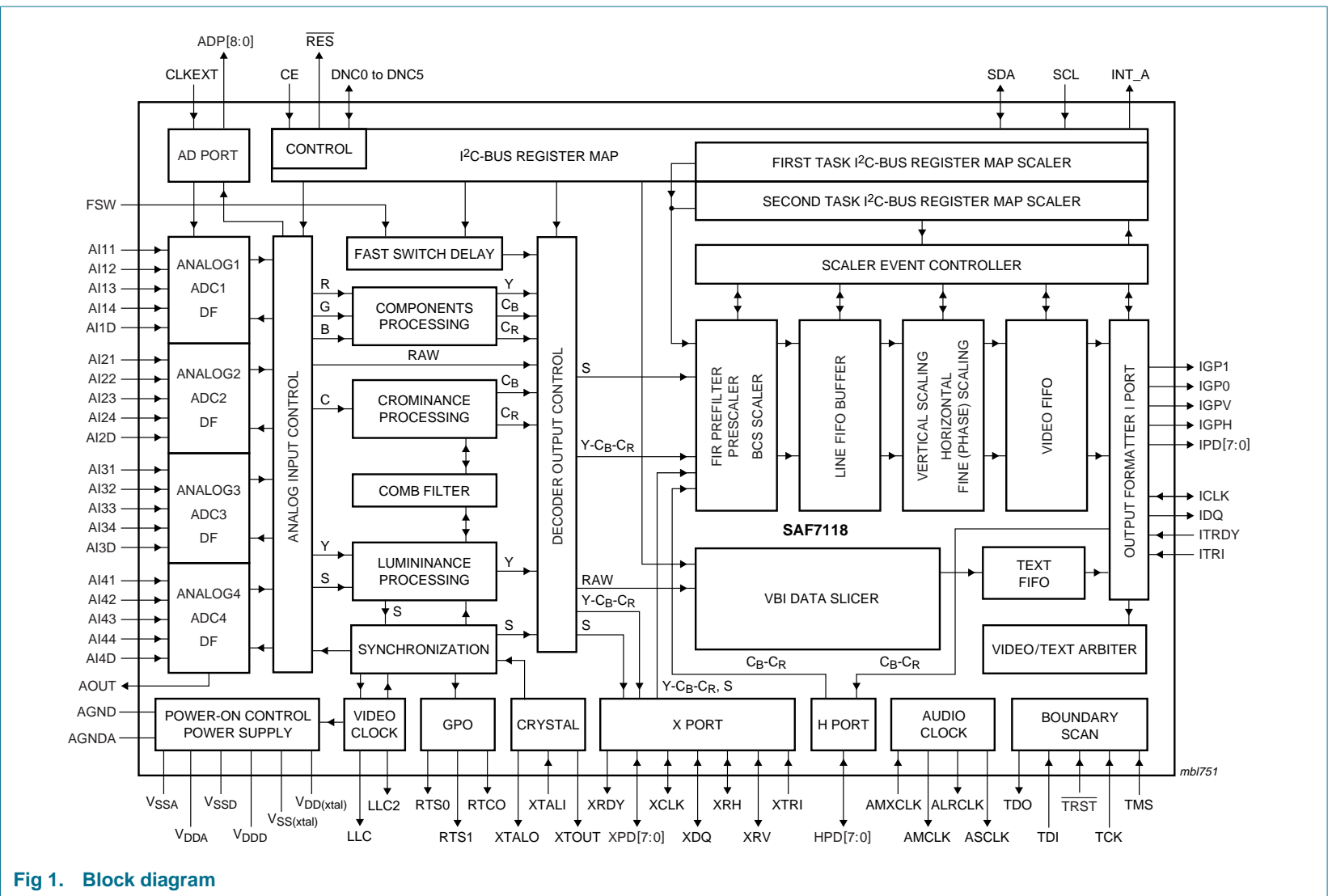

Fig 1. Block diagram

7. Pinning information

7.1 Pinning

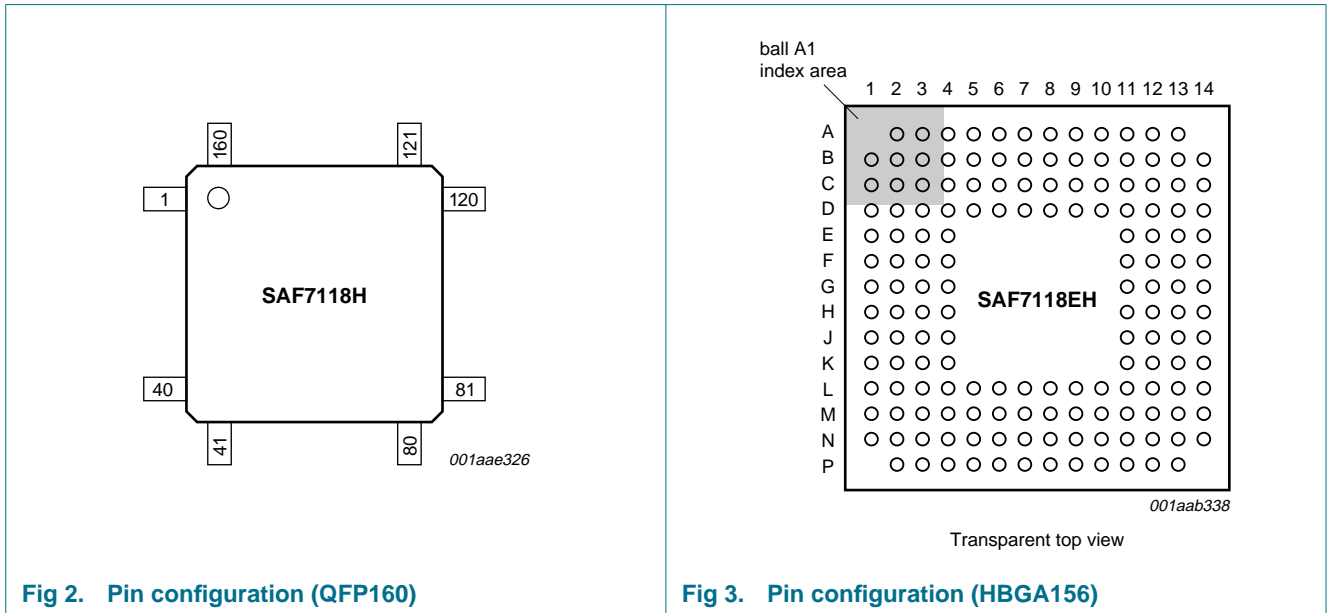

Fig 2. Pin configuration (QFP160)

Fig 3. Pin configuration (HBGA156)

Table 3: Pin allocation table

Pin	Symbol	Pin	Symbol	Pin	Symbol	Pin	Symbol
A2	XTOUT	A3	XTALO	A4	V _{SS(xtal)}	A5	TDO
A6	XRDY	A7	XCLK	A8	XPDO	A9	XPD2
A10	XPD4	A11	XPD6	A12	TEST1	A13	TEST2
B1	AI41	B2	TEST3	B3	V _{DD(xtal)}	B4	XTALI
B5	TDI	B6	TCK	B7	XDQ	B8	XPD1
B9	XPD3	B10	XPD5	B11	XTRI	B12	TEST4
B13	TEST5	B14	TEST6	C1	V _{SSA4}	C2	AGND
C3	TEST7	C4	TEST8	C5	V _{DDD13}	C6	TRST
C7	XRH	C8	V _{DDD12}	C9	V _{DDD11}	C10	V _{DDD10}
C11	XPD7	C12	TEST9	C13	TEST10	C14	TEST11
D1	AI43	D2	AI42	D3	AI4D	D4	V _{DDA4}
D5	V _{SSD13}	D6	TMS	D7	V _{SSD12}	D8	XRV
D9	V _{SSD11}	D10	V _{SSD10}	D11	V _{SSD9}	D12	V _{DDD9}
D13	TEST12	D14	HPD0	E1	AI44	E2	V _{DDA4A}
E3	AI31	E4	V _{SSA3}	E11	HPD1	E12	HPD3
E13	HPD2	E14	HPD4	F1	AI3D	F2	AI32
F3	AI33	F4	V _{DDA3}	F11	V _{SSD8}	F12	V _{DDD8}
F13	HPD5	F14	HPD6	G1	AI34	G2	V _{DDA3A}
G3	AI22	G4	AI21	G11	V _{SSD7}	G12	IPD1
G13	HPD7	G14	IPD0	H1	AI2D	H2	AI23
H3	V _{SSA2}	H4	V _{DDA2}	H11	IPD2	H12	V _{DDD7}

Table 3: Pin allocation table...continued

Pin	Symbol	Pin	Symbol	Pin	Symbol	Pin	Symbol
H13	IPD4	H14	IPD3	J1	V _{DDA2A}	J2	AI11
J3	AI24	J4	V _{SSA1}	J11	V _{SSD6}	J12	V _{DDD6}
J13	IPD6	J14	IPD5	K1	AI12	K2	AI13
K3	AI1D	K4	V _{DDA1}	K11	IPD7	K12	IGPH
K13	IGP1	K14	IGPV	L1	V _{DDA1A}	L2	AGNDA
L3	AI14	L4	V _{SSD1}	L5	V _{SSD2}	L6	ADP6
L7	ADP3	L8	V _{SSD3}	L9	V _{SSD4}	L10	RTCO
L11	V _{SSD5}	L12	ITRI	L13	IDQ	L14	IGP0
M1	AOUT	M2	V _{SSA0}	M3	V _{DDA0}	M4	V _{DDD1}
M5	V _{DDD2}	M6	ADP7	M7	ADP6	M8	V _{DDD3}
M9	V _{DDD4}	M10	RTS0	M11	V _{DDD5}	M12	AMXCLK
M13	FSW	M14	ICLK	N1	TEST13	N2	TEST14
N3	TEST15	N4	CE	N5	LLC2	N6	CLKEXT
N7	ADP5	N8	ADP0	N9	SCL	N10	RTS1
N11	ASCLK	N12	ITRDY	N13	TEST16	N14	TEST17
P2	TEST18	P3	EXMCLR	P4	LLC	P5	RES
P6	ADP8	P7	ADP4	P8	ADP1	P9	INT_A
P10	SDA	P11	AMCLK	P12	ALRCLK	P13	TEST19

7.2 Pin description

Table 4: Pin description

Symbol	Pin		Type (1)	Description
	QFP160	HBGA156		
DNC6	1	B2	O	do not connect, reserved for future extensions and for testing
AI41	2	B1	I	analog input 41
AGND	3	C2	P	analog ground
V _{SSA4}	4	C1	P	ground for analog inputs AI4x
AI42	5	D2	I	analog input 42
AI4D	6	D3	I	differential input for ADC channel 4 (pins AI41 to AI44)
AI43	7	D1	I	analog input 43
V _{DDA4}	8	D4	P	analog supply voltage for analog inputs AI4x (3.3 V)
V _{DDA4A}	9	E2	P	analog supply voltage for analog inputs AI4x (3.3 V)
AI44	10	E1	I	analog input 44
AI31	11	E3	I	analog input 31
V _{SSA3}	12	E4	P	ground for analog inputs AI3x
AI32	13	F2	I	analog input 32
AI3D	14	F1	I	differential input for ADC channel 3 (pins AI31 to AI34)
AI33	15	F3	I	analog input 33
V _{DDA3}	16	F4	P	analog supply voltage for analog inputs AI3x (3.3 V)
V _{DDA3A}	17	G2	P	analog supply voltage for analog inputs AI3x (3.3 V)

Table 4: Pin description...continued

Symbol	Pin		Type ^[1]	Description
	QFP160	HBGA156		
AI34	18	G1	I	analog input 34
AI21	19	G4	I	analog input 21
V _{SSA2}	20	H3	P	ground for analog inputs AI2x
AI22	21	G3	I	analog input 22
AI2D	22	H1	I	differential input for ADC channel 2 (pins AI24 to AI21)
AI23	23	H2	I	analog input 23
V _{DDA2}	24	H4	P	analog supply voltage for analog inputs AI2x (3.3 V)
V _{DDA2A}	25	J1	P	analog supply voltage for analog inputs AI2x (3.3 V)
AI24	26	J3	I	analog input 24
AI11	27	J2	I	analog input 11
V _{SSA1}	28	J4	P	ground for analog inputs AI1x
AI12	29	K1	I	analog input 12
AI1D	30	K3	I	differential input for ADC channel 1 (pins AI14 to AI11)
AI13	31	K2	I	analog input 13
V _{DDA1}	32	K4	P	analog supply voltage for analog inputs AI1x (3.3 V)
V _{DDA1A}	33	L1	P	analog supply voltage for analog inputs AI1x (3.3 V)
AI14	34	L3	I	analog input 14
AGNDA	35	L2	P	analog signal ground
AOUT	36	M1	O	analog test output (do not connect)
V _{DDA0}	37	M3	P	analog supply voltage (3.3 V) for internal clock generation circuit
V _{SSA0}	38	M2	P	ground for internal Clock Generation Circuit (CGC)
DNC13	39	N1	NC	do not connect, reserved for future extensions and for testing
DNC14	40	N2	I/pu	do not connect, reserved for future extensions and for testing
DNC18	41	P2	I/O	do not connect, reserved for future extensions and for testing
DNC15	42	N3	I/pd	do not connect, reserved for future extensions and for testing
EXMCLR	43	P3	I/pd	external mode clear (with internal pull-down)
CE	44	N4	I/pu	Chip Enable (CE) or reset input (with internal pull-up)
V _{DDD1}	45	M4	P	digital supply voltage 1 (peripheral cells)
LLC	46	P4	O	line-locked system clock output (27 MHz nominal)
V _{SSD1}	47	L4	P	digital ground 1 (peripheral cells)
LLC2	48	N5	O	line-locked 1/2 clock output (13.5 MHz nominal)
RES	49	P5	O	reset output (active LOW)
V _{DDD2}	50	M5	P	digital supply voltage 2 (core)
V _{SSD2}	51	L5	P	digital ground 2 (core; substrate connection)
CLKEXT	52	N6	I	external clock input intended for analog-to-digital conversion of VSB signals (36 MHz)
ADP8	53	P6	O	MSB of direct analog-to-digital converted output data (VSB)
ADP7	54	M6	O	MSB – 1 of direct analog-to-digital converted output data (VSB)
ADP6	55	L6	O	MSB – 2 of direct analog-to-digital converted output data (VSB)
ADP5	56	N7	O	MSB – 3 of direct analog-to-digital converted output data (VSB)

Table 4: Pin description...continued

Symbol	Pin		Type ^[1]	Description
	QFP160	HBGA156		
ADP4	57	P7	O	MSB – 4 of direct analog-to-digital converted output data (VSB)
ADP3	58	L7	O	MSB – 5 of direct analog-to-digital converted output data (VSB)
V _{DD3}	59	M8	P	digital supply voltage 3 (peripheral cells)
ADP2	60	M7	O	MSB – 6 of direct analog-to-digital converted output data (VSB)
ADP1	61	P8	O	MSB – 7 of direct analog-to-digital converted output data (VSB)
ADP0	62	N8	O	LSB of direct analog-to-digital converted output data (VSB)
V _{SS3}	63	L8	P	digital ground 3 (peripheral cells)
INT_A	64	P9	O/od	I ² C-bus interrupt flag (LOW if any enabled status bit has changed)
V _{DD4}	65	M9	P	digital supply voltage 4 (core)
SCL	66	N9	I(O)	serial clock input (I ² C-bus) with inactive output path
V _{SS4}	67	L9	P	digital ground 4 (core)
SDA	68	P10	I/O/od	serial data input/output (I ² C-bus)
RTS0	69	M10	O	real-time status or sync information, controlled by subaddresses 11h and 12h; see Section 10.2.18 and Section 10.2.19
RTS1	70	N10	O	real-time status or sync information, controlled by subaddresses 11h and 12h; see Section 10.2.18 and Section 10.2.19
RTCO	71	L10	O/st/pd	real-time control output; contains information about actual system clock frequency, field rate, odd/even sequence, decoder status, subcarrier frequency and phase and PAL sequence (see document “RTC Functional Description”, available on request); the RTCO pin is enabled via I ² C-bus bit RTCE; see Table 35 ^[2] ^[3]
AMCLK	72	P11	O	audio master clock output, up to 50 % of crystal clock
V _{DD5}	73	M11	P	digital supply voltage 5 (peripheral cells)
ASCLK	74	N11	O	audio serial clock output
ALRCLK	75	P12	O/st/pd	audio left/right clock output; can be strapped to supply via a 3.3 kΩ resistor to indicate that the default 24.576 MHz crystal (pin ALRCLK = LOW; internal pull-down) has been replaced by a 32.110 MHz crystal (pin ALRCLK = HIGH) ^[2] ^[4]
AMXCLK	76	M12	I	audio master external clock input
ITRDY	77	N12	I/pu	target ready input for image port data
DNC0	78	P13	I/pu	do not connect, reserved for future extensions and for testing: scan input
DNC16	79	N13	NC	do not connect, reserved for future extensions and for testing
DNC17	80	N14	NC	do not connect, reserved for future extensions and for testing
DNC19	81	-	NC	do not connect, reserved for future extensions and for testing
DNC20	82	-	NC	do not connect, reserved for future extensions and for testing
FSW	83	M13	I/pd	fast switch (blanking) with internal pull-down inserts component inputs into CVBS signal
ICLK	84	M14	I/O	clock output signal for image port, or optional asynchronous back-end clock input
IDQ	85	L13	O	output data qualifier for image port (optional: gated clock output)
ITRI	86	L12	I(O)	image port output control signal, affects all input port pins inclusive ICLK, enable and active polarity is under software control (bits IPE in subaddress 87h); output path used for testing: scan output

Table 4: Pin description...continued

Symbol	Pin		Type ^[1]	Description
	QFP160	HBGA156		
IGP0	87	L14	O	general purpose output signal 0; image port (controlled by subaddresses 84h and 85h)
V _{SSD5}	88	L11	P	digital ground 5 (peripheral cells)
IGP1	89	K13	O	general purpose output signal 1; image port (controlled by subaddresses 84h and 85h)
IGPV	90	K14	O	multi purpose vertical reference output signal; image port (controlled by subaddresses 84h and 85h)
IGPH	91	K12	O	multi purpose horizontal reference output signal; image port (controlled by subaddresses 84h and 85h)
IPD7	92	K11	O	MSB of image port data output
IPD6	93	J13	O	MSB – 1 of image port data output
IPD5	94	J14	O	MSB – 2 of image port data output
V _{DD6}	95	J12	P	digital supply voltage 6 (core)
V _{SS6}	96	J11	P	digital ground 6 (core)
IPD4	97	H13	O	MSB – 3 of image port data output
IPD3	98	H14	O	MSB – 4 of image port data output
IPD2	99	H11	O	MSB – 5 of image port data output
IPD1	100	G12	O	MSB – 6 of image port data output
V _{DD7}	101	H12	P	digital supply voltage 7 (peripheral cells)
IPD0	102	G14	O	LSB of image port data output
HPD7	103	G13	I/O	MSB of host port data I/O, extended C _B -C _R input for expansion port, extended C _B -C _R output for image port
V _{SS7}	104	G11	P	digital ground 7 (peripheral cells)
HPD6	105	F14	I/O	MSB – 1 of host port data I/O, extended C _B -C _R input for expansion port, extended C _B -C _R output for image port
V _{DD8}	106	F12	P	digital supply voltage 8 (core)
HPD5	107	F13	I/O	MSB – 2 of host port data I/O, extended C _B -C _R input for expansion port, extended C _B -C _R output for image port
V _{SS8}	108	F11	P	digital ground 8 (core)
HPD4	109	E14	I/O	MSB – 3 of host port data I/O, extended C _B -C _R input for expansion port, extended C _B -C _R output for image port
HPD3	110	E12	I/O	MSB – 4 of host port data I/O, extended C _B -C _R input for expansion port, extended C _B -C _R output for image port
HPD2	111	E13	I/O	MSB – 5 of host port data I/O, extended C _B -C _R input for expansion port, extended C _B -C _R output for image port
HPD1	112	E11	I/O	MSB – 6 of host port data I/O, extended C _B -C _R input for expansion port, extended C _B -C _R output for image port
HPD0	113	D14	I/O	LSB of host port data I/O, extended C _B -C _R input for expansion port, extended C _B -C _R output for image port
V _{DD9}	114	D12	P	digital supply voltage 9 (peripheral cells)
DNC1	115	D13	I/pu	do not connect, reserved for future extensions and for testing: scan input
DNC2	116	C14	I/pu	do not connect, reserved for future extensions and for testing: scan input

Table 4: Pin description...continued

Symbol	Pin		Type ^[1]	Description
	QFP160	HBGA156		
DNC7	117	B13	NC	do not connect, reserved for future extensions and for testing
DNC8	118	B14	NC	do not connect, reserved for future extensions and for testing
DNC11	119	C12	NC	do not connect, reserved for future extensions and for testing
DNC12	120	C13	NC	do not connect, reserved for future extensions and for testing
DNC21	121	-	NC	do not connect, reserved for future extensions and for testing
DNC22	122	-	NC	do not connect, reserved for future extensions and for testing
DNC3	123	A13	I/pu	do not connect, reserved for future extensions and for testing: scan input
DNC4	124	B12	O	do not connect, reserved for future extensions and for testing: scan output
DNC5	125	A12	I/pu	do not connect, reserved for future extensions and for testing: scan input
XTRI	126	B11	I	X port output control signal, affects all X port pins (XPD7 to XPD0, XRH, XRV, XDQ and XCLK), enable and active polarity is under software control (bits XPE in subaddress 83h)
XPD7	127	C11	I/O	MSB of expansion port data
XPD6	128	A11	I/O	MSB – 1 of expansion port data
V _{SSD9}	129	D11	P	digital ground 9 (peripheral cells)
XPD5	130	B10	I/O	MSB – 2 of expansion port data
XPD4	131	A10	I/O	MSB – 3 of expansion port data
V _{DDD10}	132	C10	P	digital supply voltage 10 (core)
V _{SSD10}	133	D10	P	digital ground 10 (core)
XPD3	134	B9	I/O	MSB – 4 of expansion port data
XPD2	135	A9	I/O	MSB – 5 of expansion port data
V _{DDD11}	136	C9	P	digital supply voltage 11 (peripheral cells)
V _{SSD11}	137	D9	P	digital ground 11 (peripheral cells)
XPD1	138	B8	I/O	MSB – 6 of expansion port data
XPD0	139	A8	I/O	LSB of expansion port data
XRV	140	D8	I/O	vertical reference I/O expansion port
XRH	141	C7	I/O	horizontal reference I/O expansion port
V _{DDD12}	142	C8	P	digital supply voltage 12 (core)
XCLK	143	A7	I/O	clock I/O expansion port
XDQ	144	B7	I/O	data qualifier for expansion port
V _{SSD12}	145	D7	P	digital ground 12 (core)
XRDY	146	A6	O	task flag or ready signal from scaler, controlled by XRQT
TRST	147	C6	I/pu	test reset input (active LOW), for boundary scan test (with internal pull-up) ^[5] ^[6] ^[7]
TCK	148	B6	I/pu	test clock for boundary scan test ^[5]
TMS	149	D6	I/pu	test mode select input for boundary scan test or scan test ^[5]
TDO	150	A5	O	test data output for boundary scan test ^[5]
V _{DDD13}	151	C5	P	digital supply voltage 13 (peripheral cells)

Table 4: Pin description...continued

Symbol	Pin		Type ^[1]	Description
	QFP160	HBGA156		
TDI	152	B5	I/pu	test data input for boundary scan test ^[5]
V _{SSD13}	153	D5	P	digital ground 13 (peripheral cells)
V _{SS(xtal)}	154	A4	P	ground for crystal oscillator
XTALI	155	B4	I	input terminal for 24.576 MHz (32.11 MHz) crystal oscillator or connection of external oscillator with TTL compatible square wave clock signal
XTALO	156	A3	O	24.576 MHz (32.11 MHz) crystal oscillator output; not connected if TTL clock input of XTALI is used
V _{DD(xtal)}	157	B3	P	supply voltage for crystal oscillator
XTOUT	158	A2	O	crystal oscillator output signal; auxiliary signal
DNC9	159	C3	NC	do not connect, reserved for future extensions and for testing
DNC10	160	C4	NC	do not connect, reserved for future extensions and for testing

- [1] I = input, O = output, P = power, NC = not connected, st = strapping, pu = pull-up, pd = pull-down, od = open-drain.
- [2] Pin strapping is done by connecting the pin to the supply via a 3.3 kΩ resistor. During the power-up reset sequence the corresponding pins are switched to input mode to read the strapping level. For the default setting no strapping resistor is necessary (internal pull-down).
- [3] Pin RTCO operates as I²C-bus slave address pin; RTCO = 0 slave address 42h/43h (default); RTCO = 1 slave address 40h/41h.
- [4] Pin ALRCLK = LOW for 24.576 MHz crystal (default); pin ALRCLK = HIGH for 32.110 MHz crystal.
- [5] In accordance with the "IEEE1149.1" standard the pads TDI, TMS, TCK and $\overline{\text{TRST}}$ are input pads with an internal pull-up transistor and TDO is a 3-state output pad.
- [6] For board design without boundary scan implementation connect the $\overline{\text{TRST}}$ pin to ground.
- [7] This pin provides easy initialization of the Boundary Scan Test (BST) circuit. $\overline{\text{TRST}}$ can be used to force the Test Access Port (TAP) controller to the TEST_LOGIC_RESET state (normal operation) at once.

Table 5: 8-bit/16-bit and alternative pin function configurations

Pin [1]	Symbol	Input			Output			I/O configuration programming bits
		8-bit input modes	16-bit input modes (only for I ² C-bus programming)	Alternative input functions	8-bit output modes	16-bit output modes (only for I ² C-bus programming)	Alternative output functions	
C11, A11, B10, A10, B9, A9, B8, A8 (127, 128, 130, 131, 134, 135, 138, 139)	XPD7 to XPD0	D1 data input	Y data input	-	D1 decoder output	-	-	XCODE[92h[3]], XPE[1:0] 83h[1:0] + pin XTRI
A7 (143)	XCLK	clock input	-	gated clock input	decoder clock output	-	-	XPE[1:0] 83h[1:0] + pin XTRI, XPCK[1:0] 83h[5:4], XCKS[92h[0]]
B7 (144)	XDQ	data qualifier input	-	-	data qualifier output (HREF and VREF gate)	-	-	XDQ[92h[1]], XPE[1:0] 83h[1:0] + pin XTRI
A6 (146)	XRDY	input ready output	-	active task A/B flag	-	-	-	XRQT[83h[2]], XPE[1:0] 83h[1:0] + pin XTRI
C7 (141)	XRH	horizontal reference input	-	-	decoder horizontal reference output	-	-	XDH[92h[2]], XPE[1:0] 83h[1:0] + pin XTRI
D8 (140)	XRV	vertical reference input	-	-	decoder vertical reference output	-	-	XDV[1:0] 92h[5:4], XPE[1:0] 83h[1:0] + pin XTRI
B11 (126)	XTRI	output enable input	-	-	-	-	-	XPE[1:0] 83h[1:0]
G13, F14, F13, E14, E12, E13, E11, D14 (103, 105, 107, 109 to 113)	HPD7 to HPD0	-	C _B -C _R data input	-	-	C _B -C _R scaler output	-	ICODE[93h[7]], ISWP[1:0] 85h[7:6], I8_16[93h[6]], IPE[1:0] 87h[1:0] + pin ITRI
K11, J13, J14, H13, H14, H11, G12, G14 (92 to 94, 97 to 99, 100, 102)	IPD7 to IPD0	-	-	-	D1 scaler output	Y scaler output	-	ICODE[93h[7]], ISWP[1:0] 85h[7:6], I8_16[93h[6]], IPE[1:0] 87h[1:0] + pin ITRI
M14 (84)	ICLK	-	-	-	clock output	-	clock input	ICKS[1:0] 80h[1:0], IPE[1:0] 87h[1:0] + pin ITRI
L13 (85)	IDQ	-	-	-	data qualifier output	-	gated clock output	ICKS[3:2] 80h[3:2], IDQP[85h[0]], IPE[1:0] 87h[1:0] + pin ITRI

Table 5: 8-bit/16-bit and alternative pin function configurations...continued

Pin [1]	Symbol	Input			Output			I/O configuration programming bits
		8-bit input modes	16-bit input modes (only for I ² C-bus programming)	Alternative input functions	8-bit output modes	16-bit output modes (only for I ² C-bus programming)	Alternative output functions	
N12 (77)	ITRDY	-	-	-	target ready input	-	-	-
K12 (91)	IGPH	-	-	-	H gate output	-	extended H gate, horizontal pulses	IDH[1:0] 84h[1:0], IRHP[85h[1]], IPE[1:0] 87h[1:0] + pin ITRI
K14 (90)	IGPV	-	-	-	V gate output	-	V-sync, vertical pulses	IDV[1:0] 84h[3:2], IRVP[85h[2]], IPE[1:0] 87h[1:0] + pin ITRI
K13 (89)	IGP1	-	-	-	general purpose	-	-	IDG1[1:0] 84h[5:4], IG1P[85h[3]], IPE[1:0] 87h[1:0] + pin ITRI
L14 (87)	IGP0	-	-	-	general purpose	-	-	IDG0[1:0] 84h[7:6], IG0P[85h[4]], IPE[1:0] 87h[1:0] + pin ITRI
L12 (86)	ITRI	-	-	-	output enable input	-	-	-

[1] Pin numbers for QFP160 in parenthesis.

8. Functional description

8.1 Decoder

8.1.1 Analog input processing

The SAF7118 offers sixteen analog signal inputs, four analog main channels with source switch, clamp circuit, analog amplifier, anti-alias filter and video 9-bit CMOS ADC with a Decimation Filter (DF); see [Figure 5](#) and [Figure 6](#).

The anti-alias filters are adapted to the line-locked clock frequency via a filter control circuit. The characteristic is shown in [Figure 4](#). During the vertical blanking period gain and clamping control are frozen.

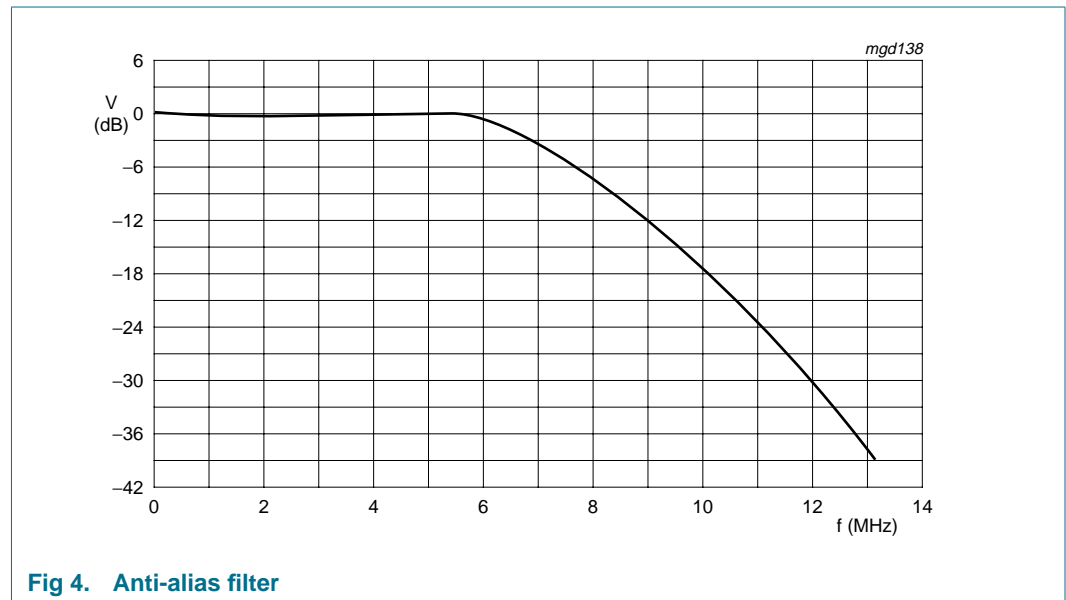

Fig 4. Anti-alias filter

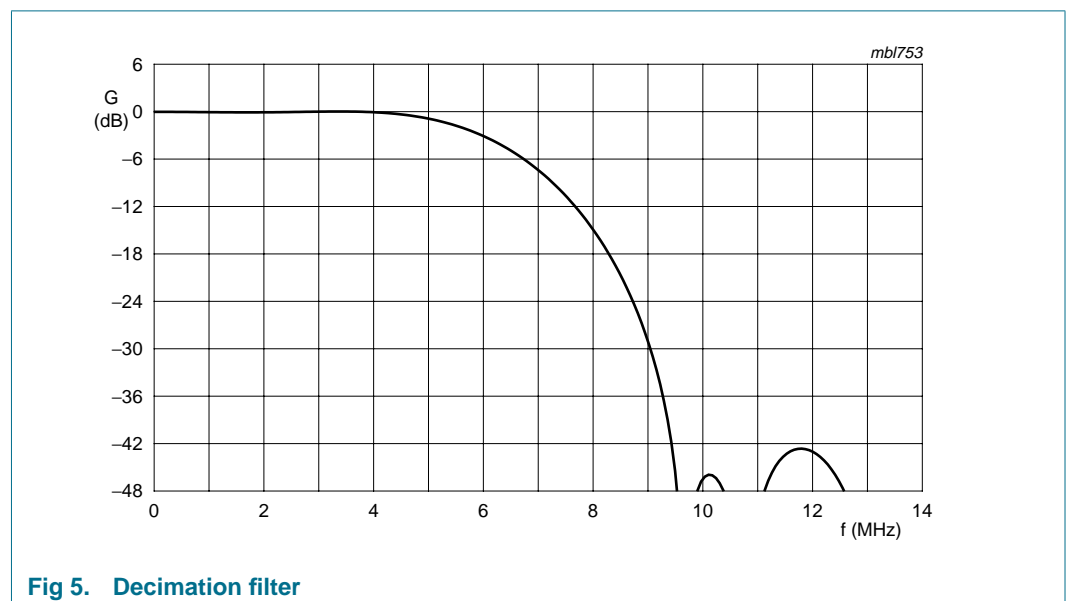

Fig 5. Decimation filter

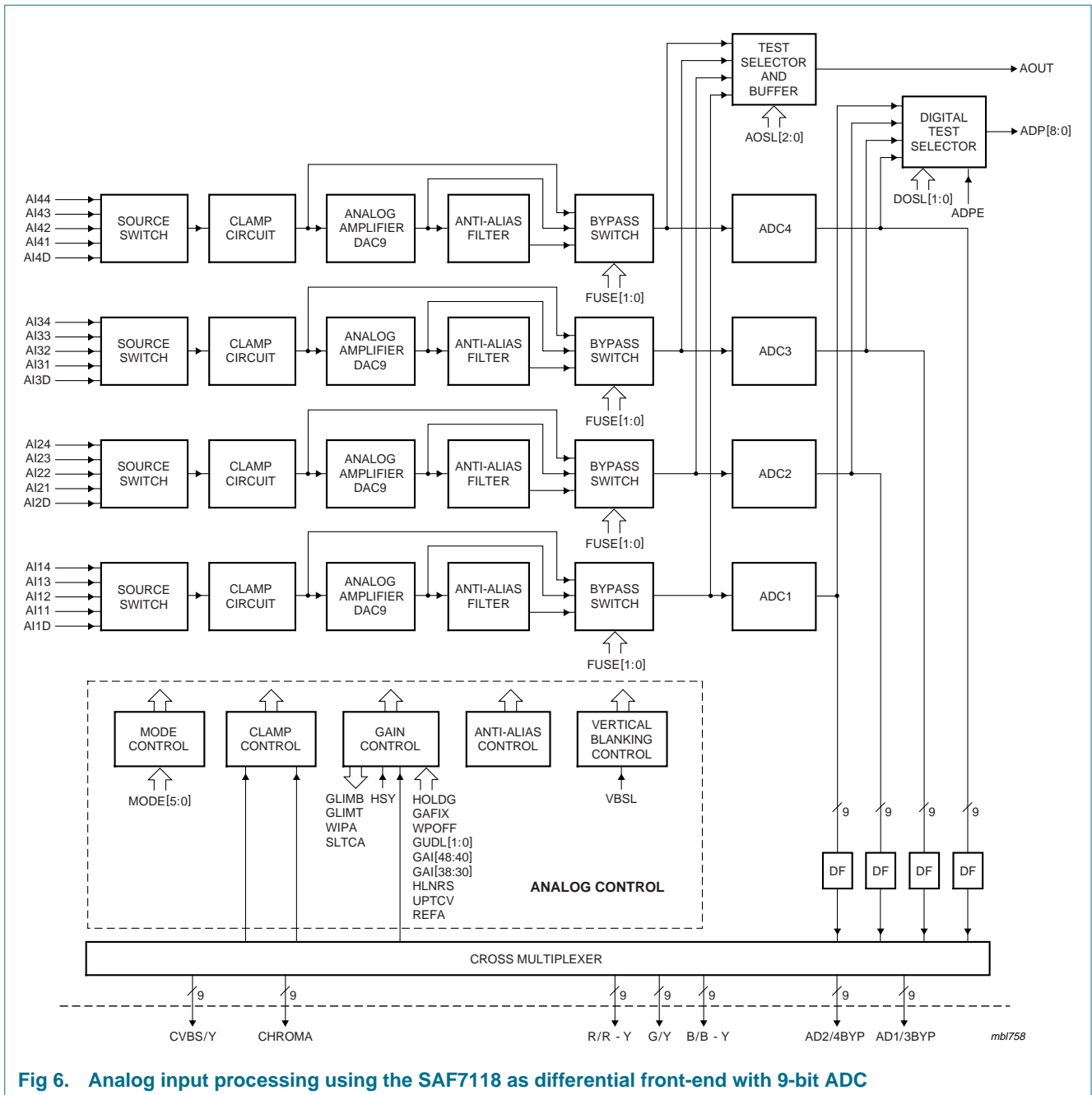

Fig 6. Analog input processing using the SAF7118 as differential front-end with 9-bit ADC

8.1.1.1 Clamping

The clamp control circuit controls the correct clamping of the analog input signals. The coupling capacitor is also used to store and filter the clamping voltage. An internal digital clamp comparator generates the information with respect to clamp-up or clamp-down. The clamping levels for the four ADC channels are fixed for luminance (120), chrominance (256) and for component inputs as component Y (32), components P_B and P_R (256) or components RGB (32). Clamping time in normal use is set with the HCL pulse on the back porch of the video signal.

8.1.1.2 Gain control

The gain control circuit receives (via the I²C-bus) the static gain levels for the four analog amplifiers or controls one of these amplifiers automatically via a built-in Automatic Gain Control (AGC) as part of the Analog Input Control (AICO).

The AGC for luminance is used to amplify a CVBS or Y signal to the required signal amplitude, matched to the ADCs input voltage range. Component inputs are gain adjusted manually at a fixed gain. The AGC active time is the sync bottom of the video signal.

Signal (white) peak control limits the gain at signal overshoots. The flow charts (see [Figure 9](#) and [Figure 10](#)) show more details of the AGC. The influence of supply voltage variation within the specified range is automatically eliminated by clamp and automatic gain control.

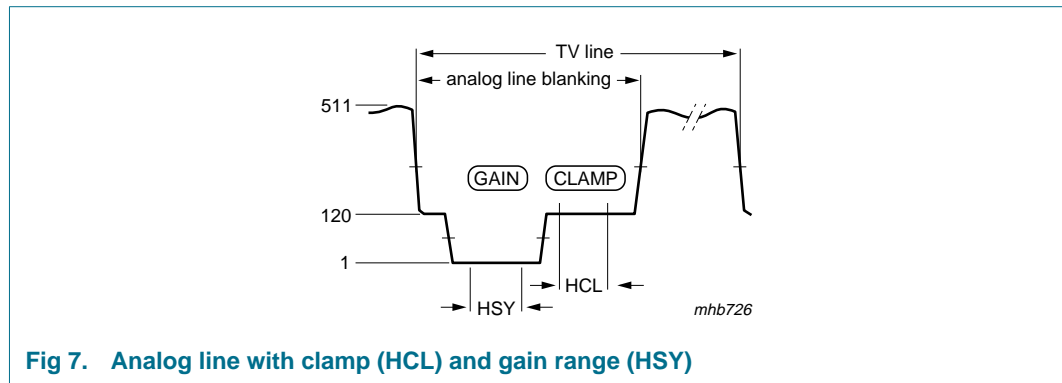

Fig 7. Analog line with clamp (HCL) and gain range (HSY)

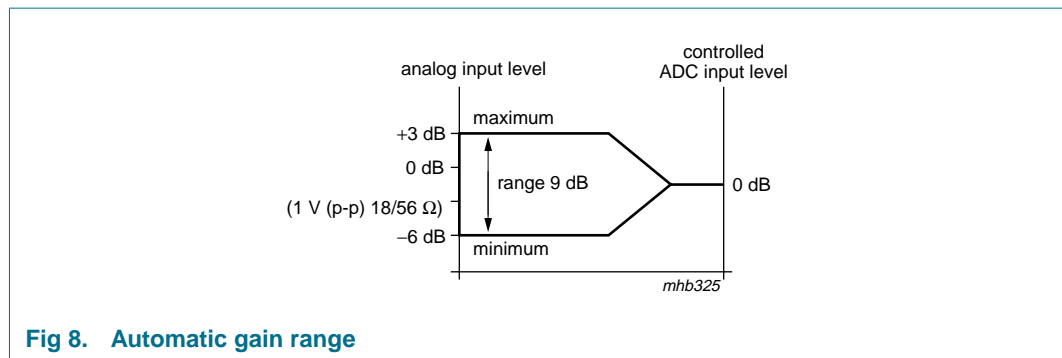
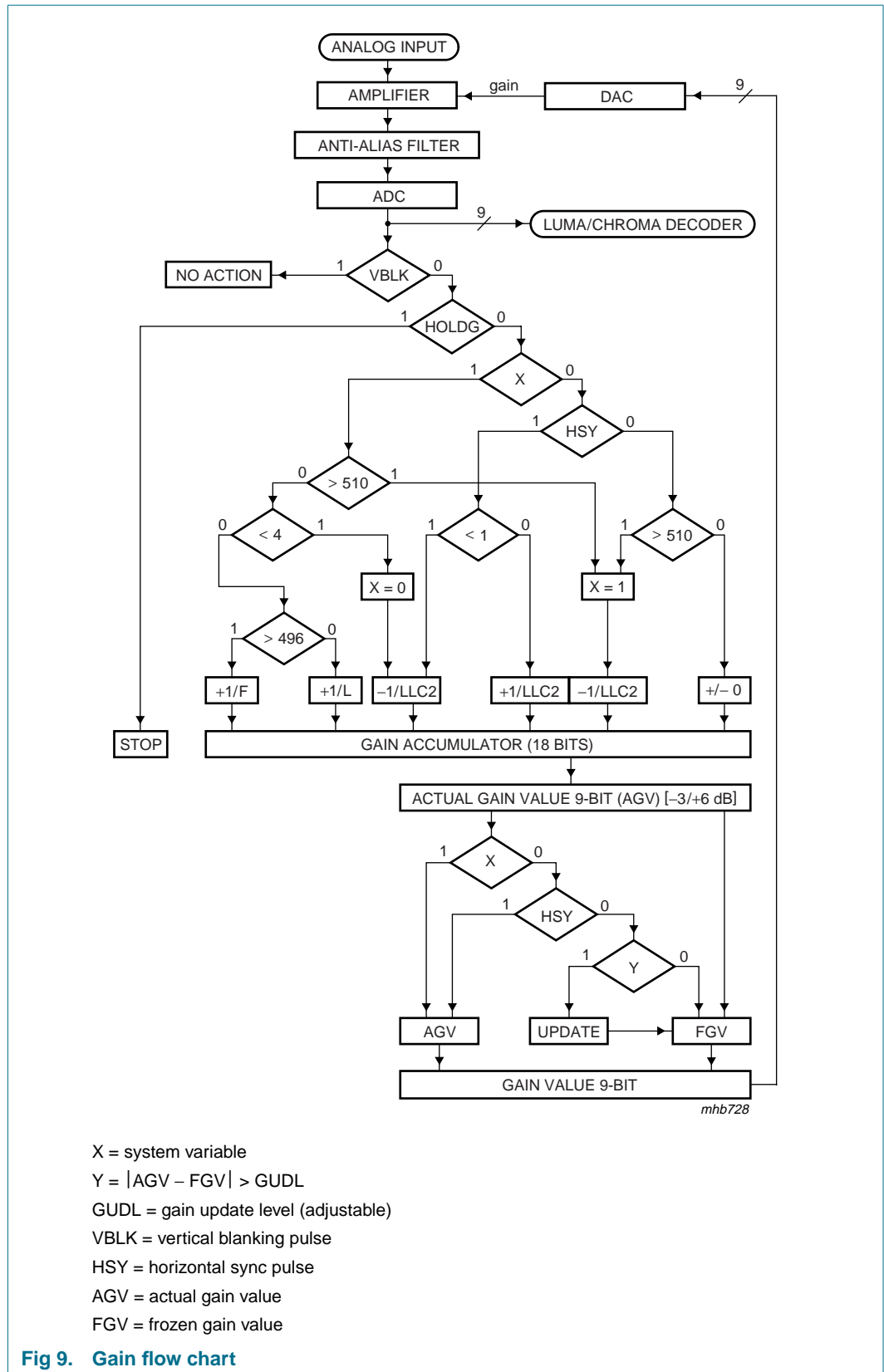
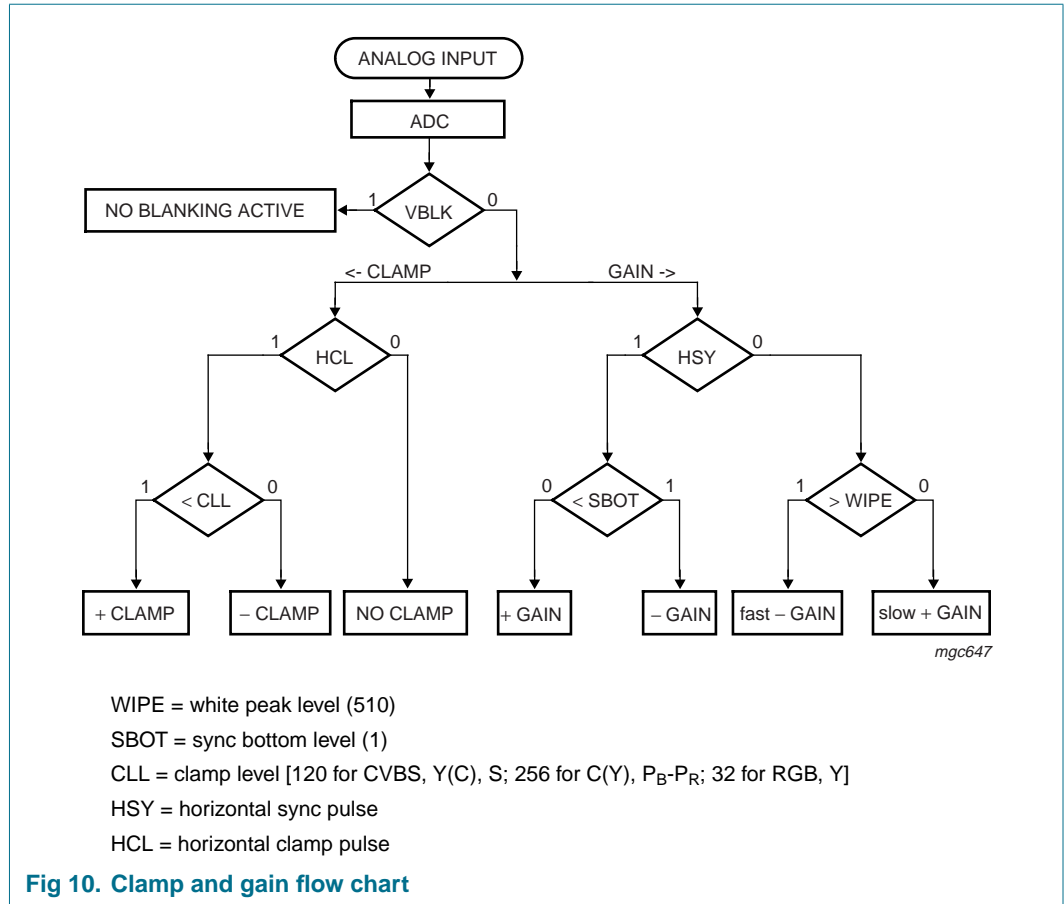

Fig 8. Automatic gain range





8.1.2 Chrominance and luminance processing

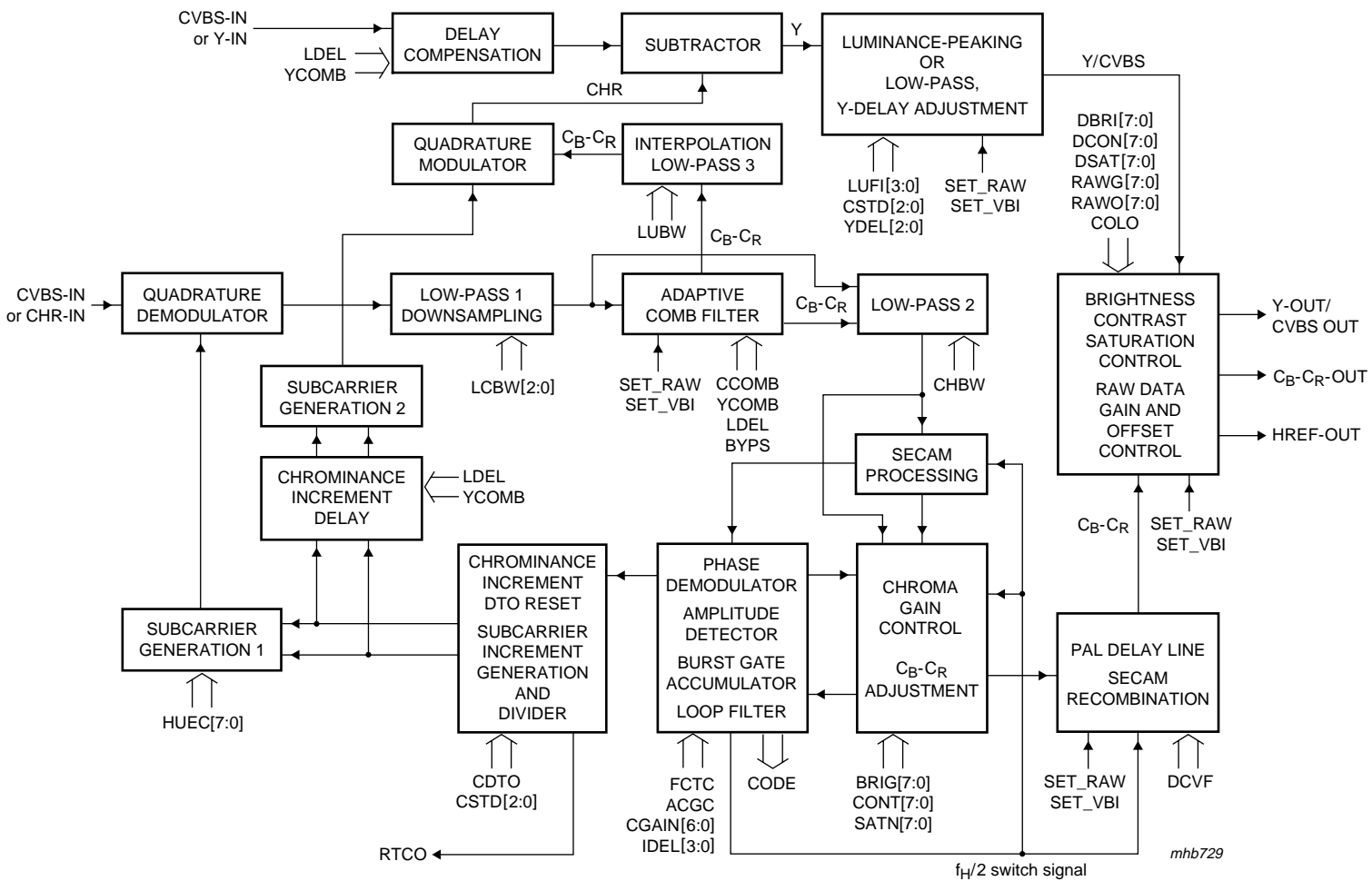

Fig 11. Chrominance and luminance processing

8.1.2.1 Chrominance path

The 9-bit CVBS or chrominance input signal is fed to the input of a quadrature demodulator, where it is multiplied by two time-multiplexed subcarrier signals from the subcarrier generation block 1 (0° and 90° phase relationship to the demodulator axis). The frequency is dependent on the chosen color standard.

The time-multiplexed output signals of the multipliers are low-pass filtered (low-pass 1). Eight characteristics are programmable via LCBW3 to LCBW0 to achieve the desired bandwidth for the color difference signals (PAL and NTSC) or the 0° and 90° FM signals (SECAM).

The chrominance low-pass 1 characteristic also influences the grade of cross luminance reduction during horizontal color transients (large chrominance bandwidth means strong suppression of cross luminance). If the Y-comb filter is disabled by YCOMB = 0 the filter influences directly the width of the chrominance notch within the luminance path (a large chrominance bandwidth means wide chrominance notch resulting in a lower luminance bandwidth).

The low-pass filtered signals are fed to the adaptive comb filter block. The chrominance components are separated from the luminance via a two-line vertical stage (four lines for PAL standards) and a decision logic between the filtered and the non-filtered output signals. This block is bypassed for SECAM signals. The comb filter logic can be enabled independently for the succeeding luminance and chrominance processing by YCOMB (subaddress 09h, bit D6) and/or CCOMB (subaddress 0Eh, bit D0). It is always bypassed during VBI or raw data lines programmable by the LCRn registers (subaddresses 41h to 57h); see [Section 8.3](#).

The separated C_B - C_R components are further processed by a second filter stage (low-pass 2) to modify the chrominance bandwidth without influencing the luminance path. Its characteristic is controlled by CHBW (subaddress 10h, bit D3). For the complete transfer characteristic of low-passes 1 and 2, see [Figure 12](#) and [Figure 13](#).

The SECAM processing (bypassed for QAM standards) contains the following blocks:

- Baseband 'bell' filters to reconstruct the amplitude and phase equalized 0° and 90° FM signals
- Phase demodulator and differentiator (FM-demodulation)
- De-emphasis filter to compensate the pre-emphasized input signal, including frequency offset compensation (DB or DR white carrier values are subtracted from the signal, controlled by the SECAM switch signal)

The succeeding chrominance gain control block amplifies or attenuates the C_B - C_R signal according to the required ITU 601/656 levels. It is controlled by the output signal from the amplitude detection circuit within the burst processing block.

The burst processing block provides the feedback loop of the chrominance PLL and contains the following:

- Burst gate accumulator
- color identification and color killer
- Comparison nominal/actual burst amplitude (PAL/NTSC standards only)
- Loop filter chrominance gain control (PAL/NTSC standards only)

- Loop filter chrominance PLL (only active for PAL/NTSC standards)
- PAL/SECAM sequence detection, H/2-switch generation

The increment generation circuit produces the Discrete Time Oscillator (DTO) increment for both subcarrier generation blocks. It contains a division by the increment of the line-locked clock generator to create a stable phase-locked sine signal under all conditions (e.g. for non-standard signals).

The PAL delay line block eliminates crosstalk between the chrominance channels in accordance with the PAL standard requirements. For NTSC color standards the delay line can be used as an additional vertical filter. If desired, it can be switched off by $DCVF = 1$. It is always disabled during VBI or raw data lines programmable by the LCRn registers (subaddresses 41h to 57h); see [Section 8.3](#). The embedded line delay is also used for SECAM recombination (cross-over switches).

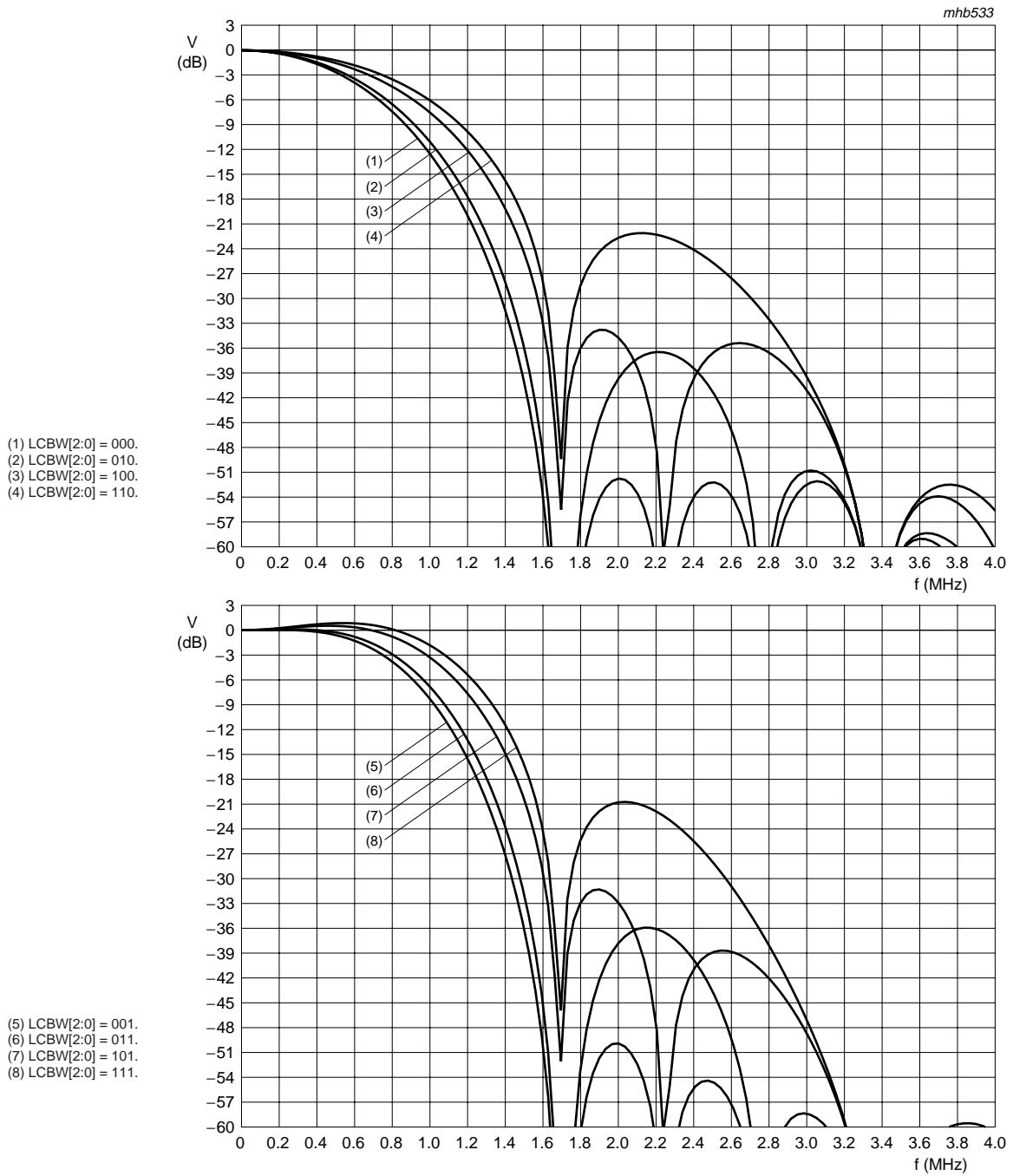

Fig 12. Transfer characteristics of the chrominance low-pass at CHBW = 0

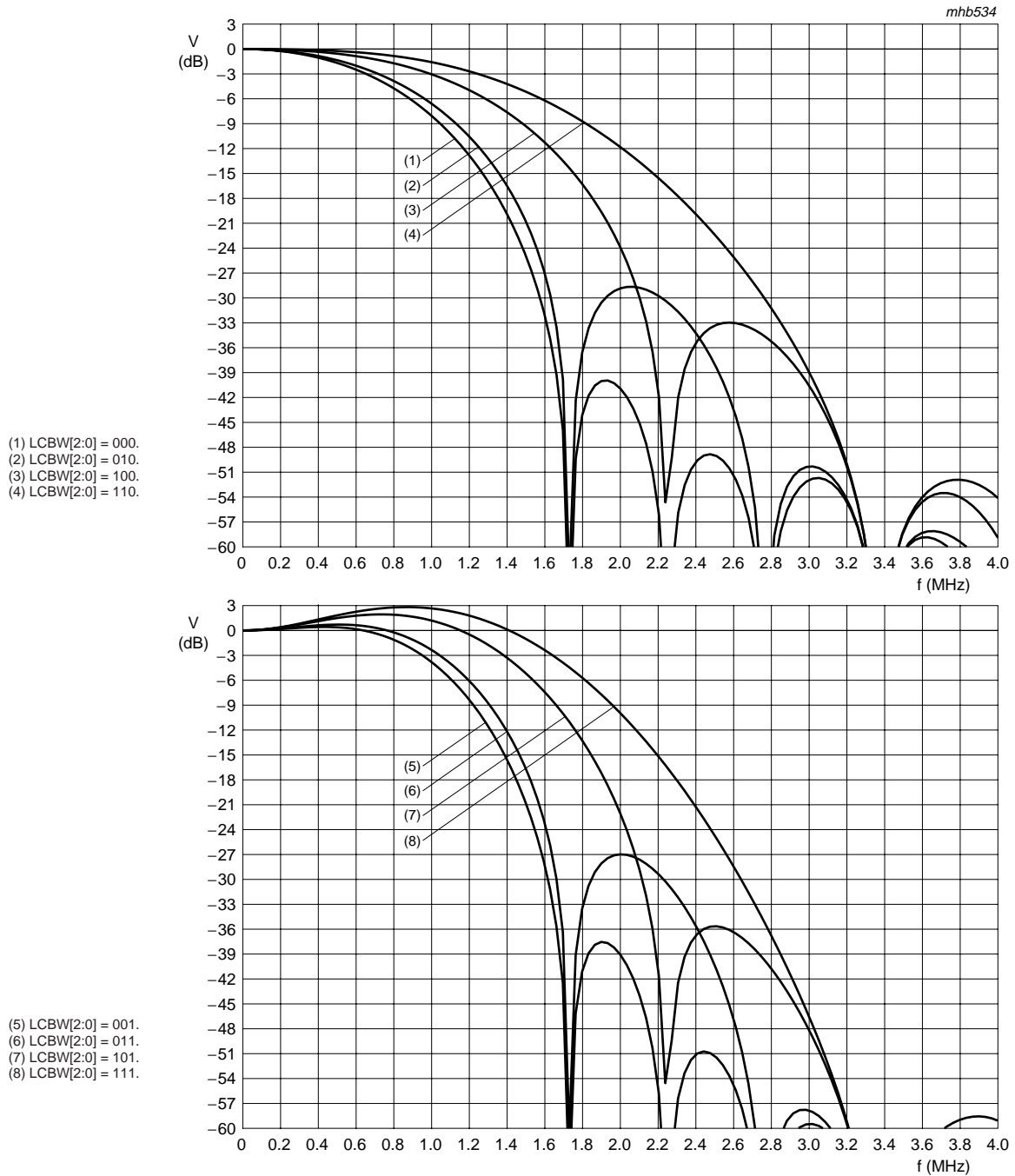

Fig 13. Transfer characteristics of the chrominance low-pass at CHBW = 1

8.1.2.2 Luminance path

The rejection of the chrominance components within the 9-bit CVBS or Y input signal is achieved by subtracting the remodulated chrominance signal from the CVBS input.

The comb filtered C_B - C_R components are interpolated (upsampled) by the low-pass 3 block. Its characteristic is controlled by LUBW (subaddress 09h, bit D4) to modify the width of the chrominance 'notch' without influencing the chrominance path. The programmable frequency characteristics available, in conjunction with the LCBW2 to LCBW0 settings, can be seen in [Figure 14](#) to [Figure 17](#). It should be noted that these frequency curves are only valid for Y-comb disabled filter mode ($YCOMB = 0$). In comb filter mode the frequency response is flat. The centre frequency of the notch is automatically adapted to the chosen color standard.

The interpolated C_B - C_R samples are multiplied by two time-multiplexed subcarrier signals from the subcarrier generation block 2. This second DTO is locked to the first subcarrier generator by an increment delay circuit matched to the processing delay, which is different for PAL and NTSC standards according to the chosen comb filter algorithm. The two modulated signals are finally added to build the remodulated chrominance signal.

The frequency characteristic of the separated luminance signal can be further modified by the succeeding luminance filter block. It can be configured as peaking (resolution enhancement) or low-pass block by LUF13 to LUF10 (subaddress 09h, bits D3 to D0). The 16 resulting frequency characteristics can be seen in [Figure 18](#). The LUF13 to LUF10 settings can be used as a user programmable sharpness control.

The luminance filter block also contains the adjustable Y-delay part; programmable by YDEL2 to YDEL0 (subaddress 11h, bits D2 to D0).

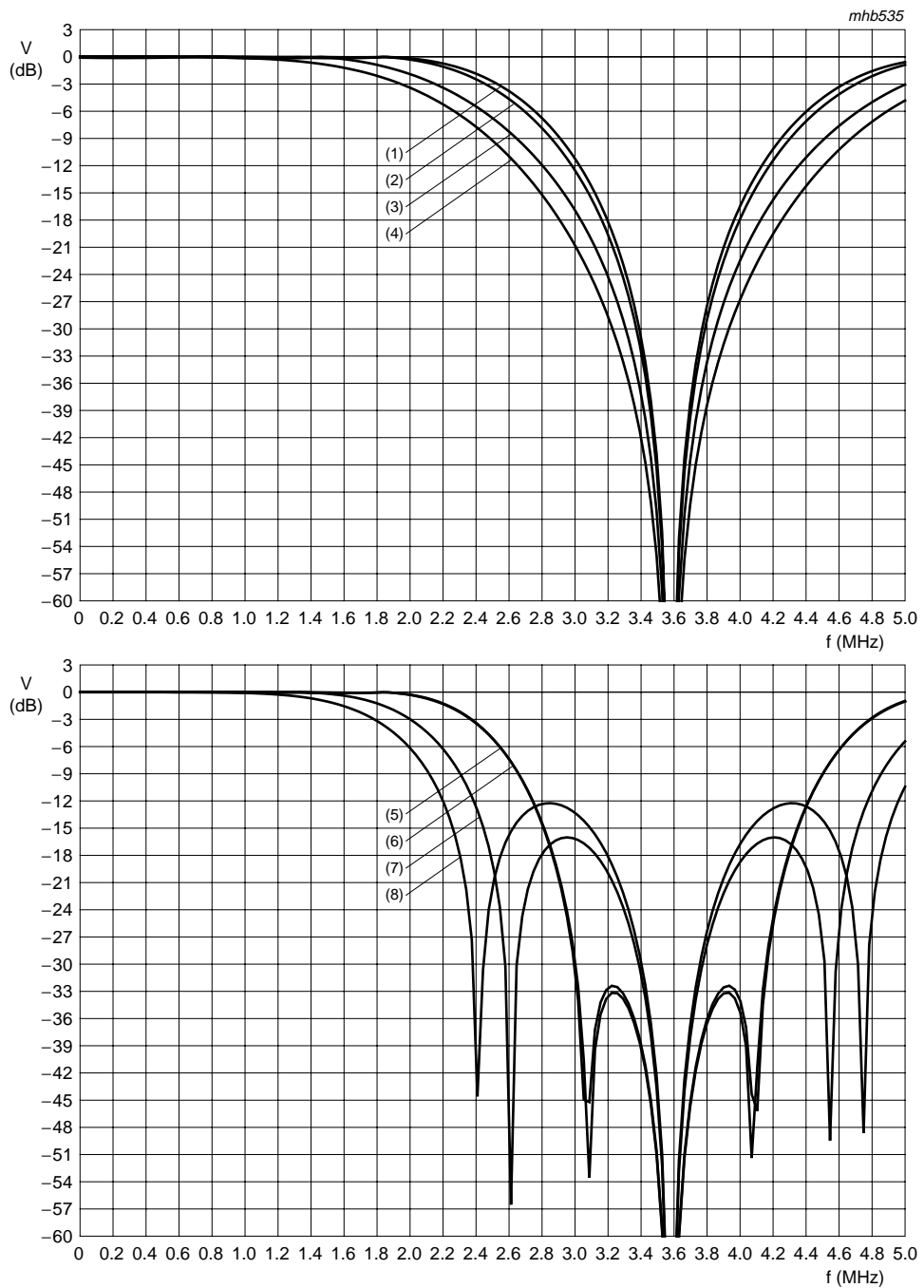

Fig 14. Transfer characteristics of the luminance notch filter in 3.58 MHz mode (Y-comb filter disabled) at LUBW = 0

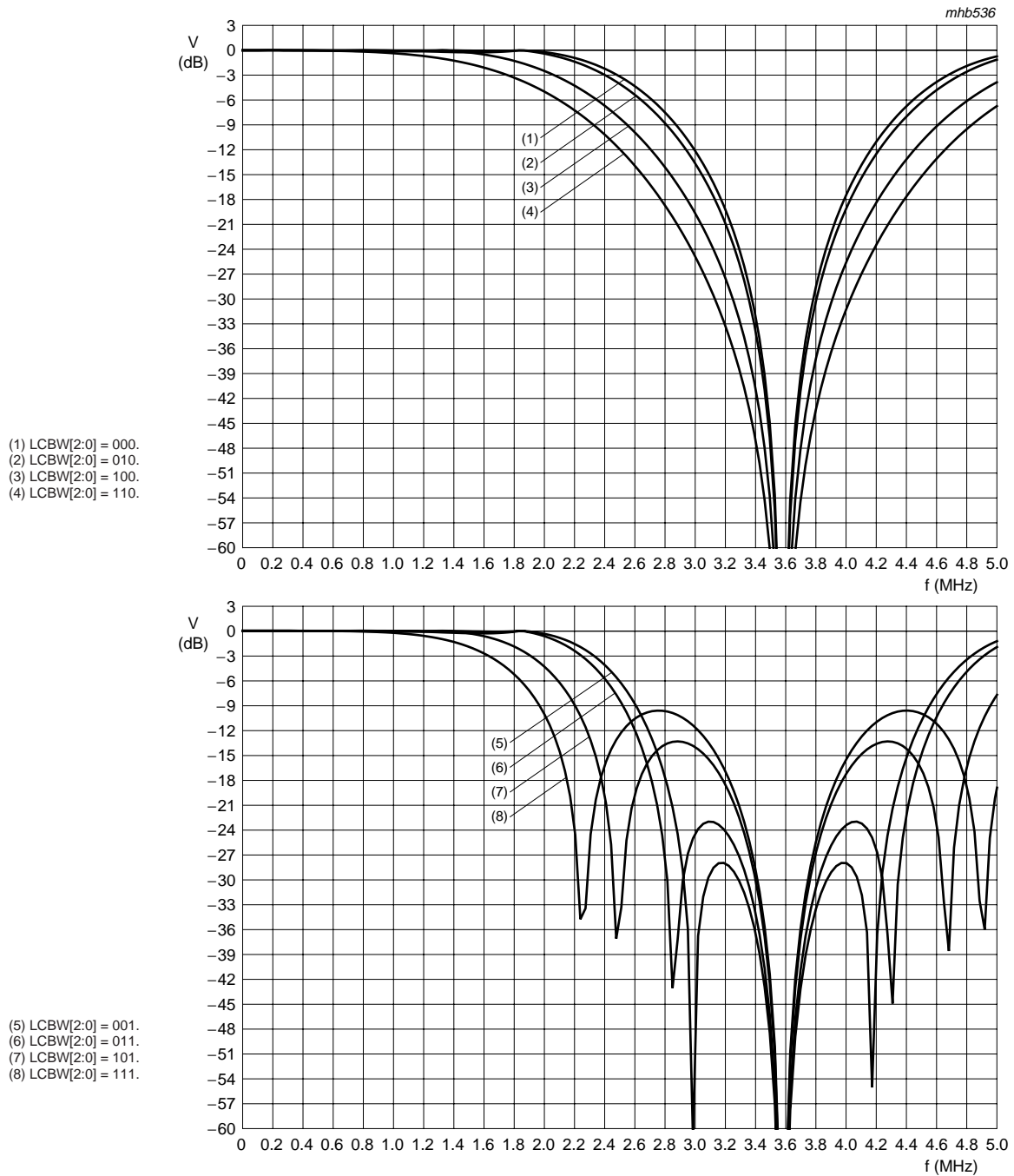

Fig 15. Transfer characteristics of the luminance notch filter in 3.58 MHz mode (Y-comb filter disabled) at LUBW = 1

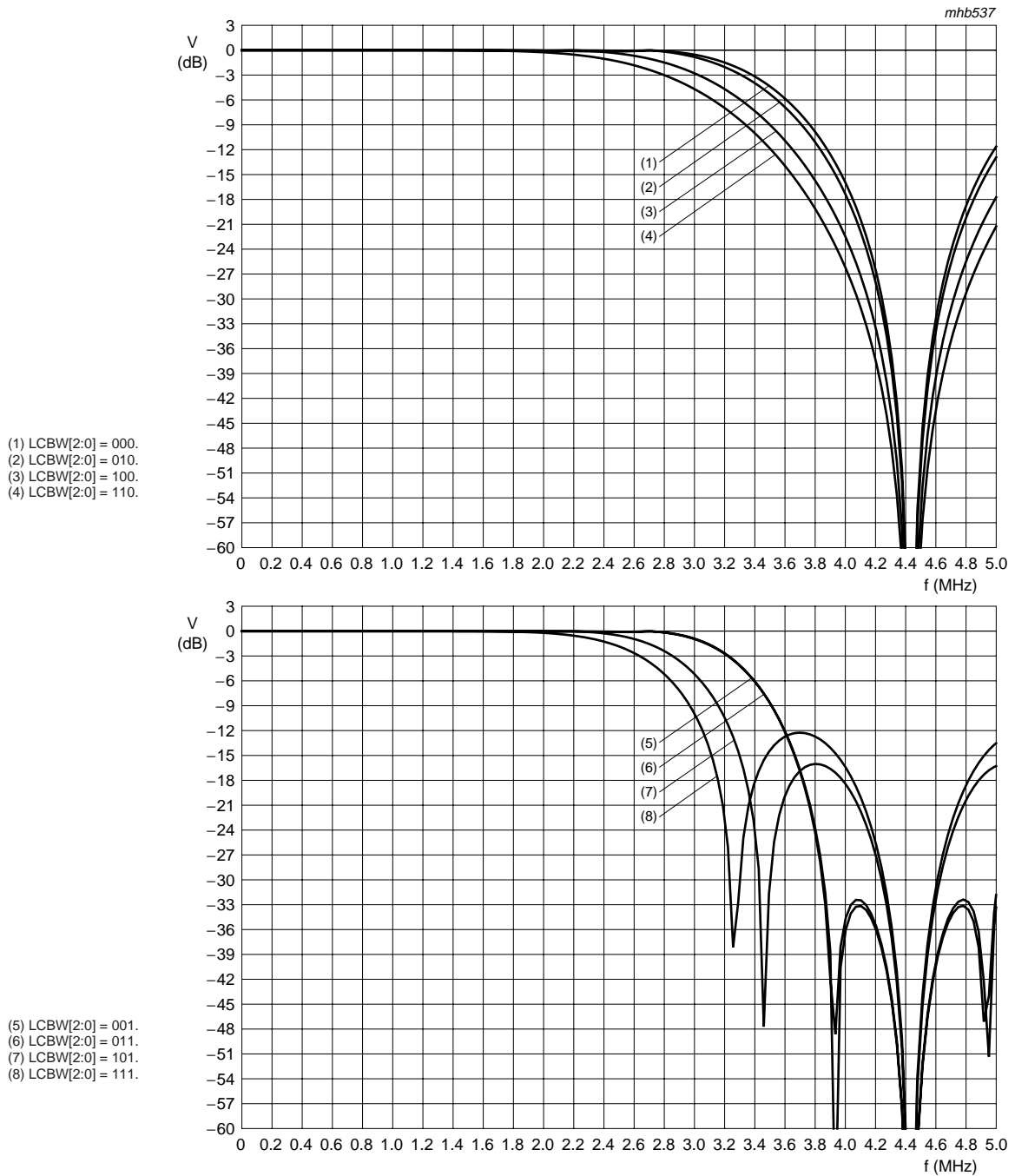

Fig 16. Transfer characteristics of the luminance notch filter in 4.43 MHz mode (Y-comb filter disabled) at LUBW = 0

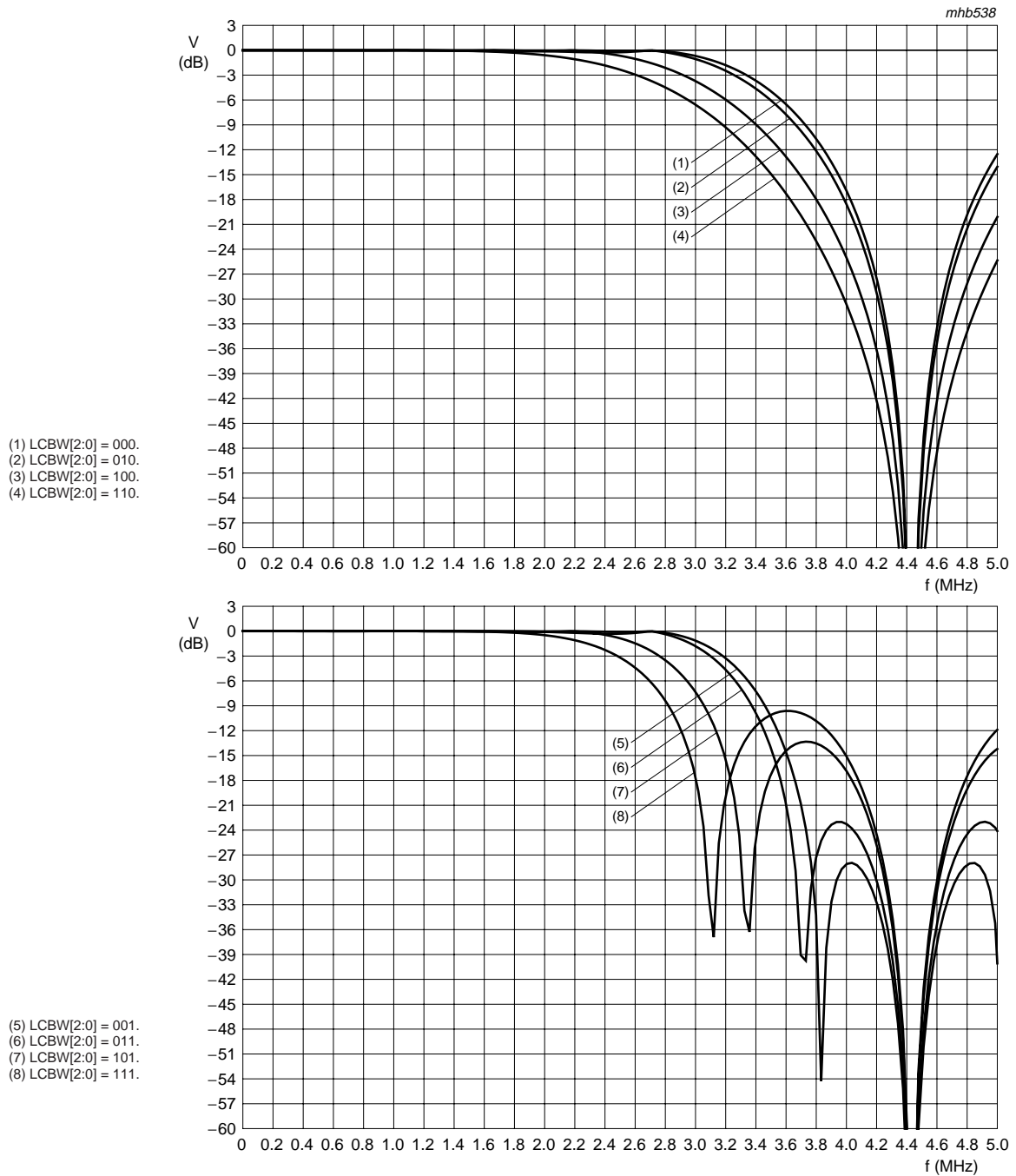

Fig 17. Transfer characteristics of the luminance notch filter in 4.43 MHz mode (Y-comb filter disabled) at LUBW = 1

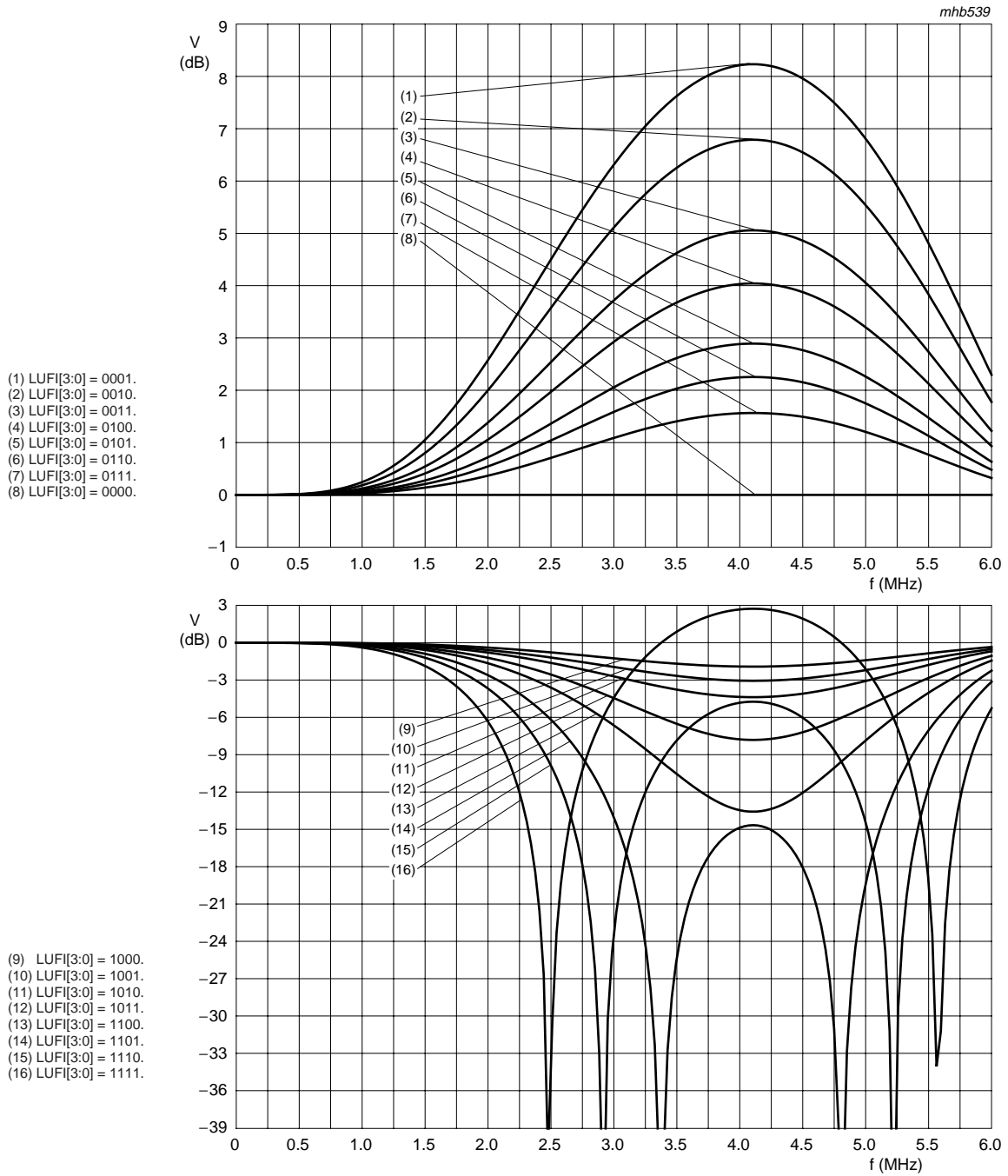
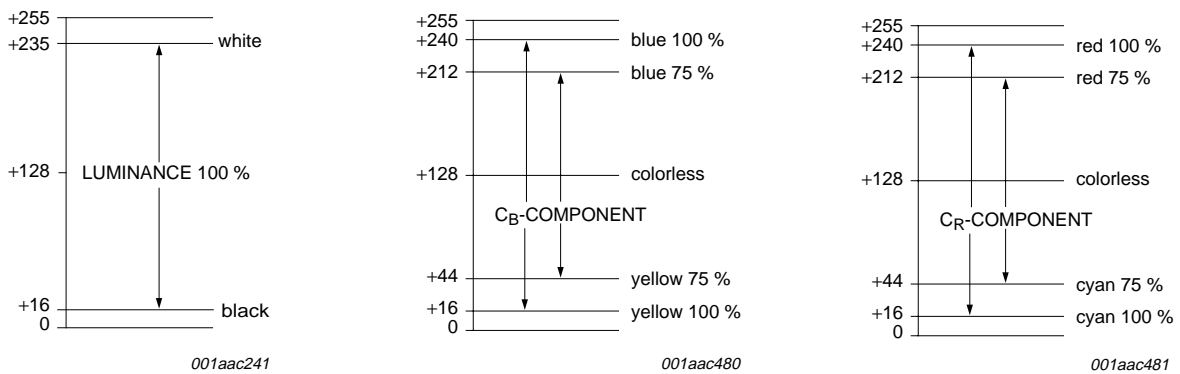

Fig 18. Transfer characteristics of the luminance peaking/low-pass filter (sharpness)

8.1.2.3 Brightness Contrast Saturation (BCS) control and decoder output levels

The resulting Y (CVBS) and C_B-C_R signals are fed to the BCS block, which contains the following functions:

- Chrominance saturation control by DSAT7 to DSAT0
- Luminance contrast and brightness control by DCON7 to DCON0 and DBRI7 to DBRI0
- Raw data (CVBS) gain and offset adjustment by RAWG7 to RAWG0 and RAWO7 to RAWO0
- Limiting Y-C_B-C_R or CVBS to the values 1 (minimum) and 254 (maximum) to fulfil "ITU Recommendation 601/656".



"ITU Recommendation 601/656" digital levels with default BCS (decoder) settings DCON[7:0] = 44h, DBRI[7:0] = 80h and DSAT[7:0] = 40h.

Equations for modification to the Y-C_B-C_R levels via BCS control I²C-bus bytes DBRI, DCON and DSAT.

$$\text{Luminance: } Y_{OUT} = \text{Int} \left[\frac{DCON}{68} \times (Y - 128) \right] + DBRI$$

$$\text{Chrominance: } (C_R C_B)_{OUT} = \text{Int} \left[\frac{DSAT}{64} \times (C_R C_B - 128) \right] + 128$$

It should be noted that the resulting levels are limited to 1 to 254 in accordance with "ITU Recommendation 601/656".

- a. Y output range.
- b. C_B output range.
- c. C_R output range.

Fig 19. Y-C_B-C_R range for scaler input and X port output

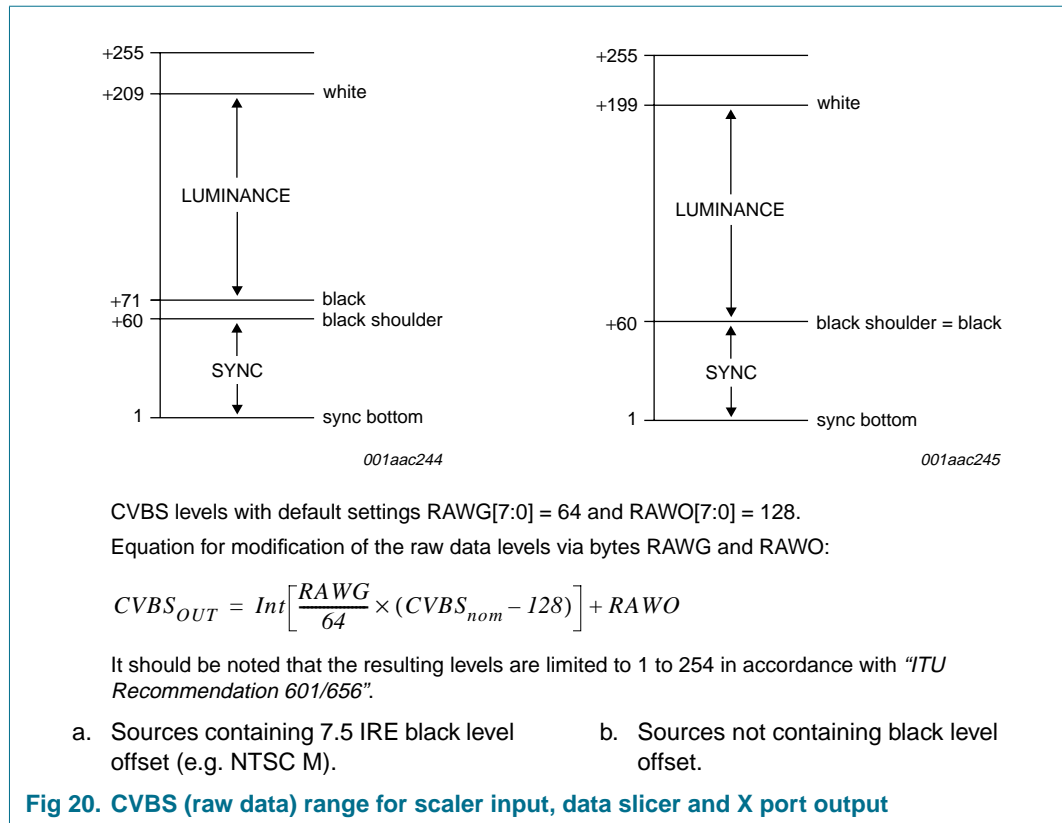

8.1.3 Synchronization

The prefiltered luminance signal is fed to the synchronization stage. Its bandwidth is further reduced to 1 MHz in a low-pass filter. The sync pulses are sliced and fed to the phase detectors where they are compared with the sub-divided clock frequency. The resulting output signal is applied to the loop filter to accumulate all phase deviations. Internal signals (e.g. HCL and HSY) are generated in accordance with analog front-end requirements. The loop filter signal drives an oscillator to generate the line frequency control signal LFCO; see [Figure 21](#).

The detection of 'pseudo syncs' as part of the Macrovision copy protection standard is also achieved within the synchronization circuit.

The result is reported as flag COPRO within the decoder status byte at subaddress 1Fh.

8.1.4 Clock generation circuit

The internal CGC generates all clock signals required for the video input processor.

The internal signal LFCO is a digital-to-analog converted signal provided by the horizontal PLL. It is the multiple of the line frequency:

- 6.75 MHz = 429 × f_H (50 Hz), or
- 6.75 MHz = 432 × f_H (60 Hz)

The LFCO signal is multiplied by a factor of 2 and 4 in the internal PLL circuit (including phase detector, loop filtering, VCO and frequency divider) to obtain the output clock signals. The rectangular output clocks have a 50 % duty factor.

Table 6: Decoder clock frequencies

Clock	Frequency (MHz)
XTALO	24.576 or 32.110
LLC	27
LLC2	13.5
LLC4 (internal)	6.75
LLC8 (virtual)	3.375

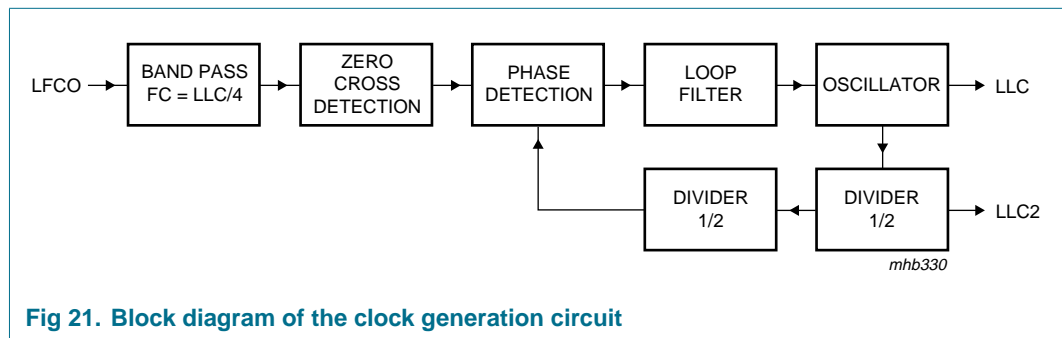
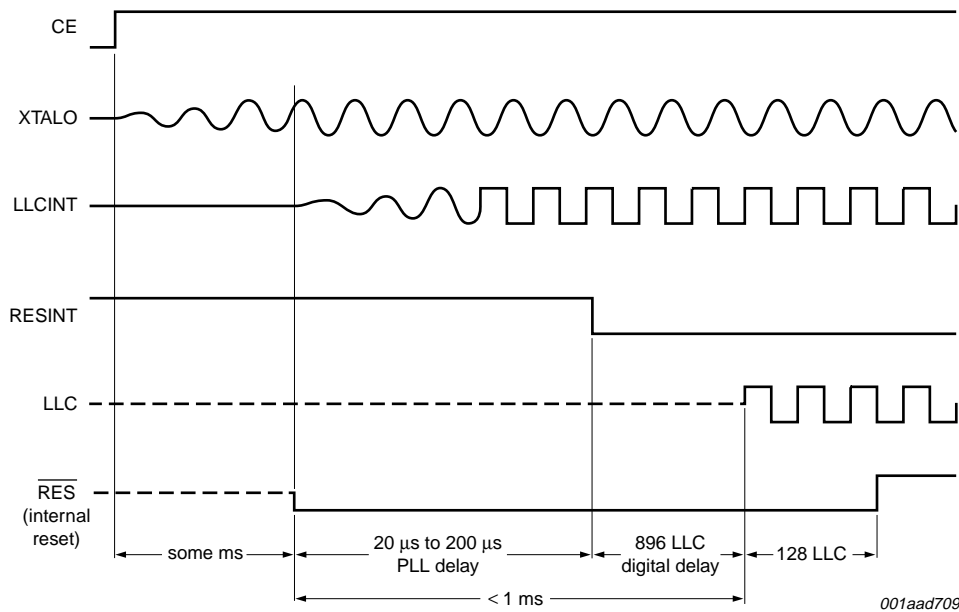
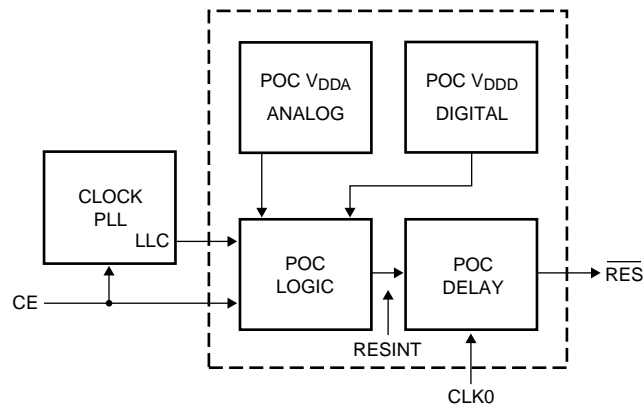

Fig 21. Block diagram of the clock generation circuit

8.1.5 Power-on reset and CE input

A missing clock, insufficient digital or analog V_{DDA0} supply voltages (below 2.8 V) will start the reset sequence; all outputs are forced to 3-state (see Figure 22). The indicator output \overline{RES} is LOW for approximately 128 LLC after the internal reset and can be applied to reset other circuits of the digital TV system.

It is possible to force a reset by pulling the CE input to ground. After the rising edge of CE and sufficient power supply voltage, the outputs LLC, LLC2 and SDA return from 3-state to active, while the other signals have to be activated via programming.



001aad709

- POC = Power-on control
- CE = chip enable input
- XTALO = crystal oscillator output
- LLCINT = internal system clock
- RESINT = internal reset
- LLC = line-locked clock output
- $\overline{\text{RES}}$ = reset output

Fig 22. Power-on control circuit

8.2 Component video processing

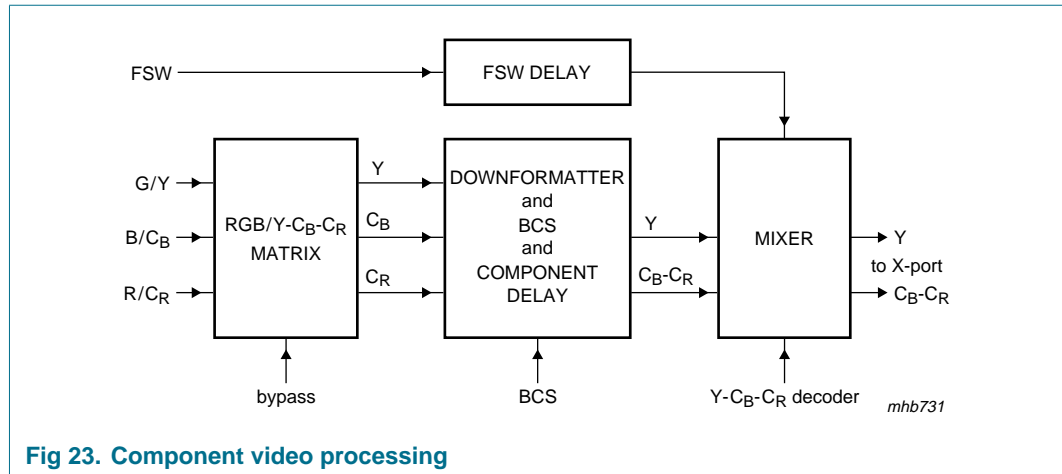

Fig 23. Component video processing

8.2.1 RGB-to-(Y-C_B-C_R) matrix

The matrix converts the RGB signals from the analog-to-digital converters/downsamplers to the Y-C_B-C_R representation. The input and output word widths are 9 bits. The matrix has a gain factor of 1. The block provides a delay compensated bypass for component input signals.

The matrix is represented by the following equations:

- $Y = 0.299 \times R + 0.587 \times G + 0.114 \times B$
- $C_B = 0.5772 \times (B - Y)$
- $C_R = 0.7296 \times (R - Y)$

8.2.2 Downformatter

The block mainly consists of 2 parts: the color difference signal downsampler and the Y-path.

The color difference signals are first passed through low-pass filters which reduce alias effects due to the lower data rate. The ITU sampling scheme requires that both color difference samples fit to the first Y sample of the current time slot. Thus the C_R signal is delayed by 1 clock before it is fed to the multiplexer. The switch signal defines the data multiplex phase at the output: a '0' marks the first clock of a time slot, this is a C_B sample. The output is fed through a register, so that the multiplexer runs with the opposite phase.

The delay compensation for the Y signal already provides most of the registers required for a small high-pass filter. It can be used to compensate high frequency losses in the analog part. It provides 2 dB gain at 6.75 MHz.

The Y high-pass filter frequency response is shown in [Figure 26](#). The DC gain of the filter is 1, so a limiter is required at the filter output. The current implementation clips at the maximum values of 0 and 511. The entire filter can be controlled by the I²C-bus bit CMFI in subaddress 29h.

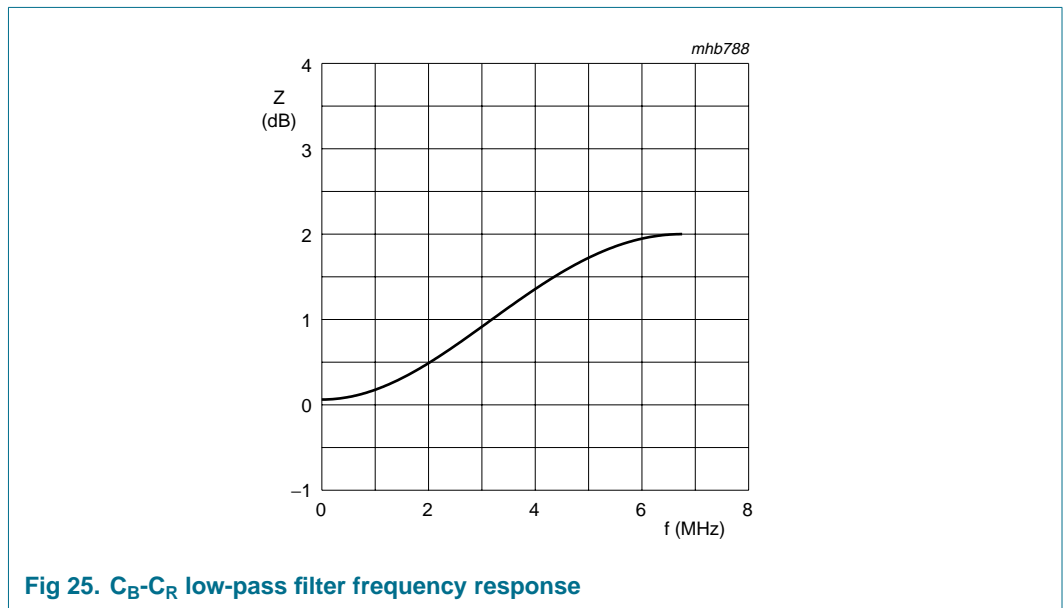
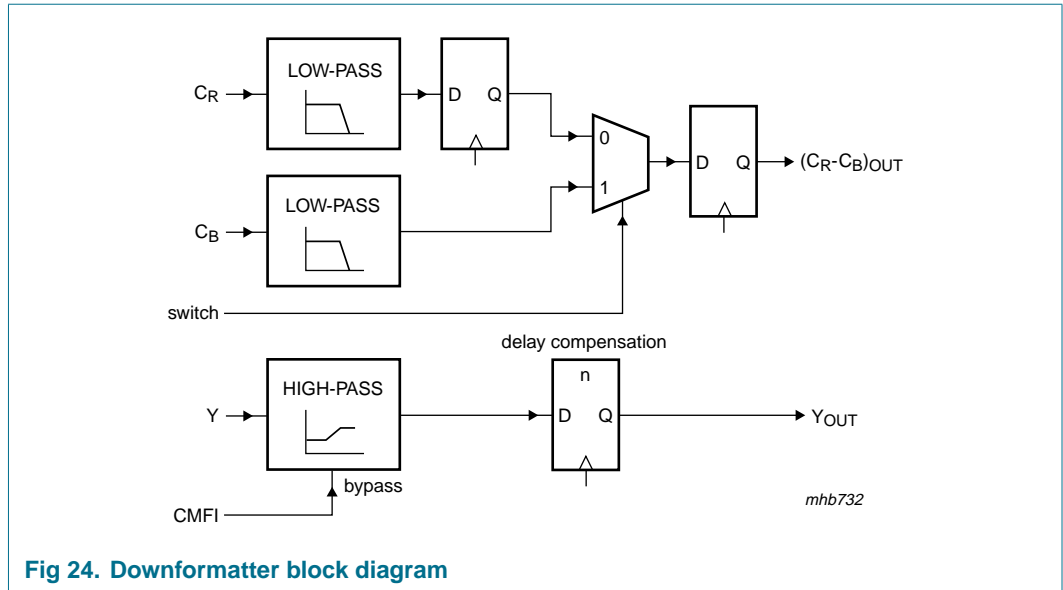

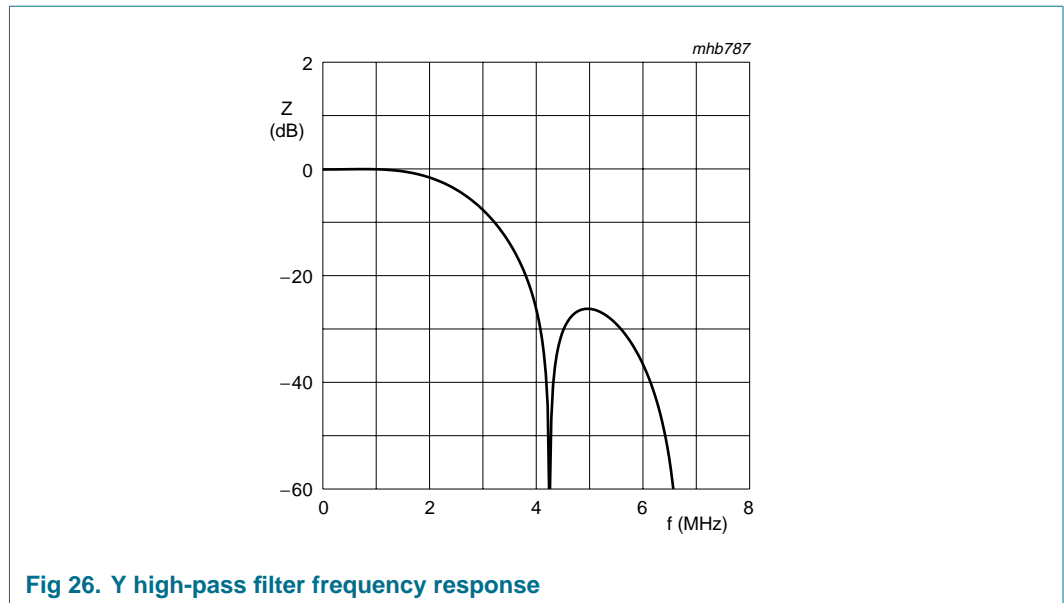

8.2.3 Component video BCS control

The resulting Y and C_B - C_R signals are fed to the Component BCS (CBCS) block, which contains the following functions:

- Chrominance saturation control by CSAT7 to CSAT0
- Luminance contrast and brightness control by CCON7 to CCON0 and CBRI7 to CBRI0
- Limiting Y- C_B - C_R or CVBS to the values 1 (minimum) and 254 (maximum) to fulfil "ITU Recommendation 601/656".

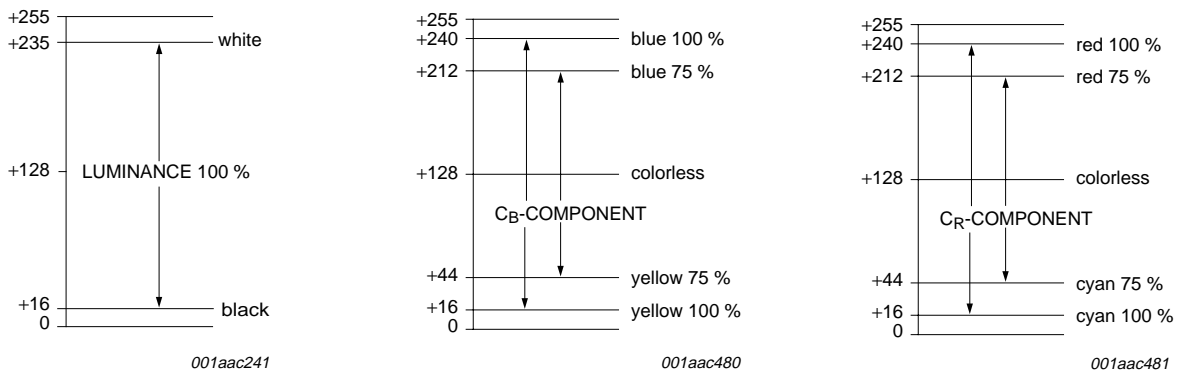

"ITU Recommendation 601/656" digital levels with default CBCS (decoder) settings CCON[7:0] = 44h, CBRI[7:0] = 80h and CSAT[7:0] = 40h.

Equations for modification to the Y-C_B-C_R levels via CBCS control I²C-bus bytes CBRI, CCON and CSAT.

$$\text{Luminance: } Y_{OUT} = \text{Int} \left[\frac{CCON}{68} \times (Y - 128) \right] + CBRI$$

$$\text{Chrominance: } (C_B C_R)_{OUT} = \text{Int} \left[\frac{CSAT}{64} \times (C_B, C_R - 128) \right] + 128$$

It should be noted that the resulting levels are limited to 1 to 254 in accordance with "ITU Recommendation 601/656".

- a. Y output range.
- b. C_B output range.
- c. C_R output range.

Fig 27. Components Y-C_B-C_R range

8.3 Decoder output formatter

The output interface block of the decoder part contains the ITU 656 formatter for the expansion port data output XPD7 to XPD0 (for a detailed description see [Section 9.5.1](#)) and the control circuit for the signals needed for the internal paths to the scaler and data slicer part. It also controls the selection of the reference signals for the RT port (RTCO, RTS0 and RTS1) and the expansion port (XRH, XRV and XDQ).

The generation of the decoder data type control signals SET_RAW and SET_VBI is also done within this block. These signals are decoded from the requested data type for the scaler input and/or the data slicer, selectable by the control registers LCR2 to LCR24 (see [Section 10](#); subaddresses 41h to 57h).

For each LCR value from 2 to 23 the data type can be programmed individually; LCR2 to LCR23 refer to line numbers. The selection in LCR24 values is valid for the rest of the corresponding field. The upper nibble contains the value for field 1 (odd), the lower nibble for field 2 (even). The relationship between LCR values and line numbers can be adjusted via VOFF8 to VOFF0, located in subaddresses 5Bh (bit D4) and 5Ah (bits D7 to D0) and FOFF subaddress 5Bh (bit D7). The recommended values are VOFF[8:0] = 03h for 50 Hz sources (with FOFF = 0) and VOFF[8:0] = 06h for 60 Hz sources (with FOFF = 1), to accommodate line number conventions as used for PAL, SECAM and NTSC standards; see [Figure 28](#) and [Figure 29](#).

Table 7: Data formats at decoder output

Data type number	Data type	Decoder output data format
0	teletext EuroWST, CCST	raw
1	European closed caption	raw
2	Video Programming Service (VPS)	raw
3	wide screen signalling bits	raw
4	US teletext (WST)	raw
5	US closed caption (line 21)	raw
6	video component signal, VBI region	Y-C _B -C _R 4 : 2 : 2
7	CVBS data	raw
8	teletext	raw
9	VITC/EBU time codes (Europe)	raw
10	VITC/SMPTE time codes (USA)	raw
11	reserved	raw
12	US NABTS	raw
13	MOJI (Japanese)	raw
14	Japanese format switch (L20/22)	raw
15	video component signal, active video region	Y-C _B -C _R 4 : 2 : 2

LINE NUMBER (1st FIELD)	521	522	523	524	525	1	2	3	4	5	6	7	8	9
	active video					equalization pulses			serration pulses			equalization pulses		
LINE NUMBER (2nd FIELD)	259	260	261	262	263	264	265	266	267	268	269	270	271	272
	active video					equalization pulses			serration pulses			equalization pulses		
LCR	24					2		3	4	5	6	7	8	9

LINE NUMBER (1st FIELD)	10	11	12	13	14	15	16	17	18	19	20	21	22	23	24	25
	nominal VBI lines F1												active video			
LINE NUMBER (2nd FIELD)	273	274	275	276	277	278	279	280	281	282	283	284	285	286	287	288
	nominal VBI lines F2												active video			
LCR	10	11	12	13	14	15	16	17	18	19	20	21	22	23	24	

001aad425

Vertical line offset, VOFF[8:0] = 06h (subaddresses 5Bh[4] and 5Ah[7:0]); horizontal pixel offset, HOFF[10:0] = 347h (subaddresses 5Bh[2:0] and 59h[7:0]); FOFF = 1 (subaddress 5Bh[7])

Fig 28. Relationship of LCR to line numbers in 525 lines/60 Hz systems

LINE NUMBER (1st FIELD)	621	622	623	624	625	1	2	3	4	5
	active video			equalization pulses		serration pulses			equalization pulses	
LINE NUMBER (2nd FIELD)	309	310	311	312	313	314	315	316	317	318
	active video			equalization pulses		serration pulses			equalization pulses	
LCR	24					2		3	4	5

LINE NUMBER (1st FIELD)	6	7	8	9	10	11	12	13	14	15	16	17	18	19	20	21	22	23	24	25
	nominal VBI lines F1																			active video
LINE NUMBER (2nd FIELD)	319	320	321	322	323	324	325	326	327	328	329	330	331	332	333	334	335	336	337	338
	nominal VBI lines F2																			active video
LCR	6	7	8	9	10	11	12	13	14	15	16	17	18	19	20	21	22	23	24	

001aad426

Vertical line offset, VOFF[8:0] = 03h (subaddresses 5Bh[4] and 5Ah[7:0]); horizontal pixel offset, HOFF[10:0] = 347h (subaddresses 5Bh[2:0] and 59h[7:0]); FOFF = 0 (subaddress 5Bh[7])

Fig 29. Relationship of LCR to line numbers in 625 lines/50 Hz systems

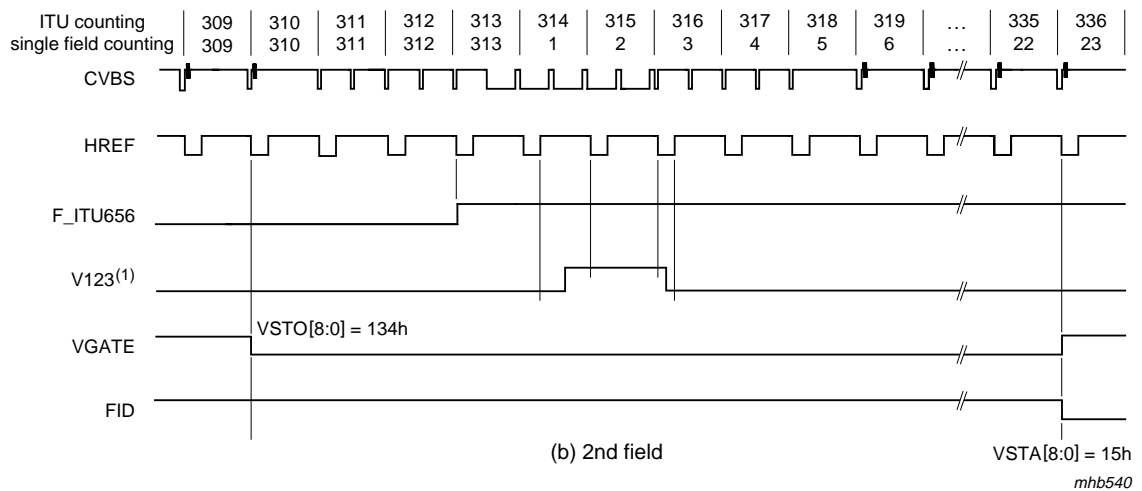
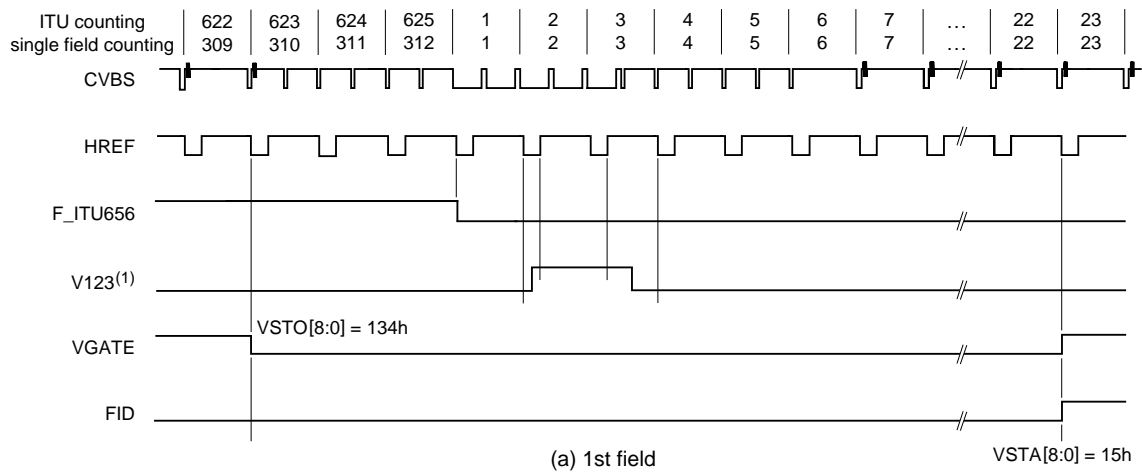

(1) The inactive going edge of the V123 signal indicates whether the field is odd or even. If HREF is active during the falling edge of V123, the field is ODD (field 1). If HREF is inactive during the falling edge of V123, the field is EVEN. The specific position of the slope is dependent on the internal processing delay and may change a few clock cycles from version to version.

The control signals listed above are available on pins RTS0, RTS1, XRH and XRV according to [Table 8](#).

For further information see [Table 56](#), [Table 57](#) and [Table 58](#).

mhb540

Fig 30. Vertical timing diagram for 50 Hz/625 line systems

Table 8: Control signals

Name	RTS0	RTS1	XRH	XRV
HREF	X	X	X	-
F_ITU656	-	-	-	X
V123	X	X	-	X
VGATE	X	X	-	-
FID	X	X	-	-

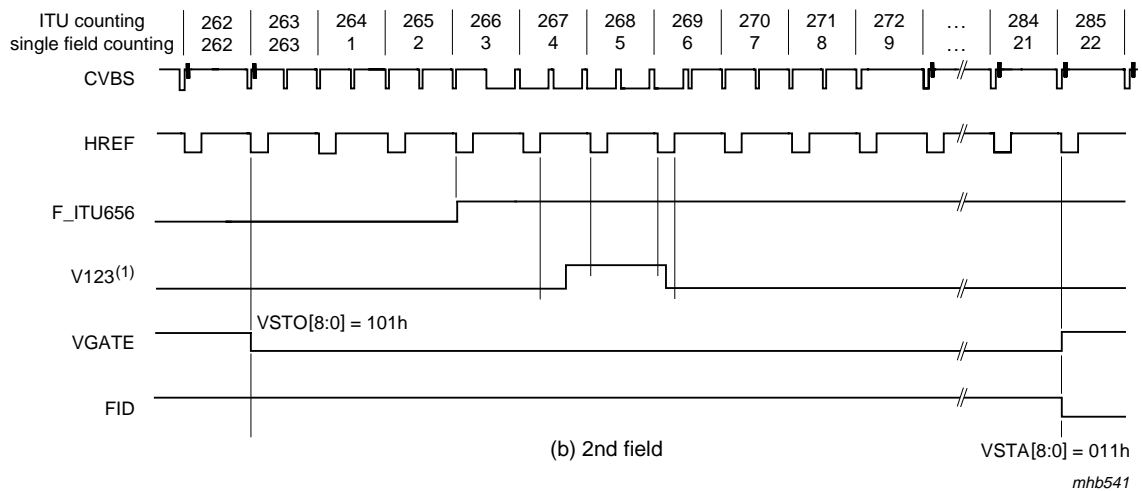
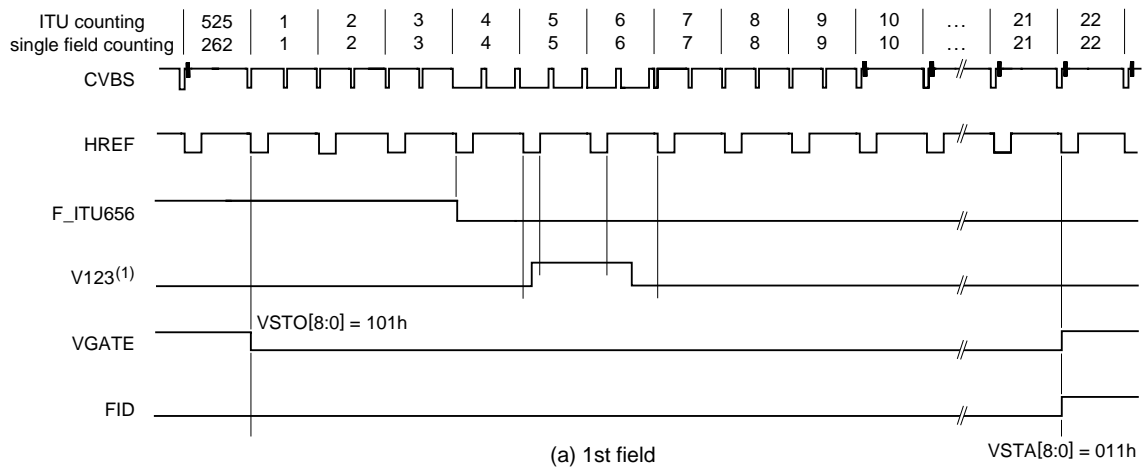

mhb541

- (1) The inactive going edge of the V123 signal indicates whether the field is odd or even. If HREF is active during the falling edge of V123, the field is ODD (field 1). If HREF is inactive during the falling edge of V123, the field is EVEN. The specific position of the slope is dependent on the internal processing delay and may change a few clock cycles from version to version.

The control signals listed above are available on pins RTS0, RTS1, XRH and XRV according to [Table 8](#).

For further information see [Table 56](#), [Table 57](#) and [Table 58](#).

Fig 31. Vertical timing diagram for 60 Hz/525 line systems

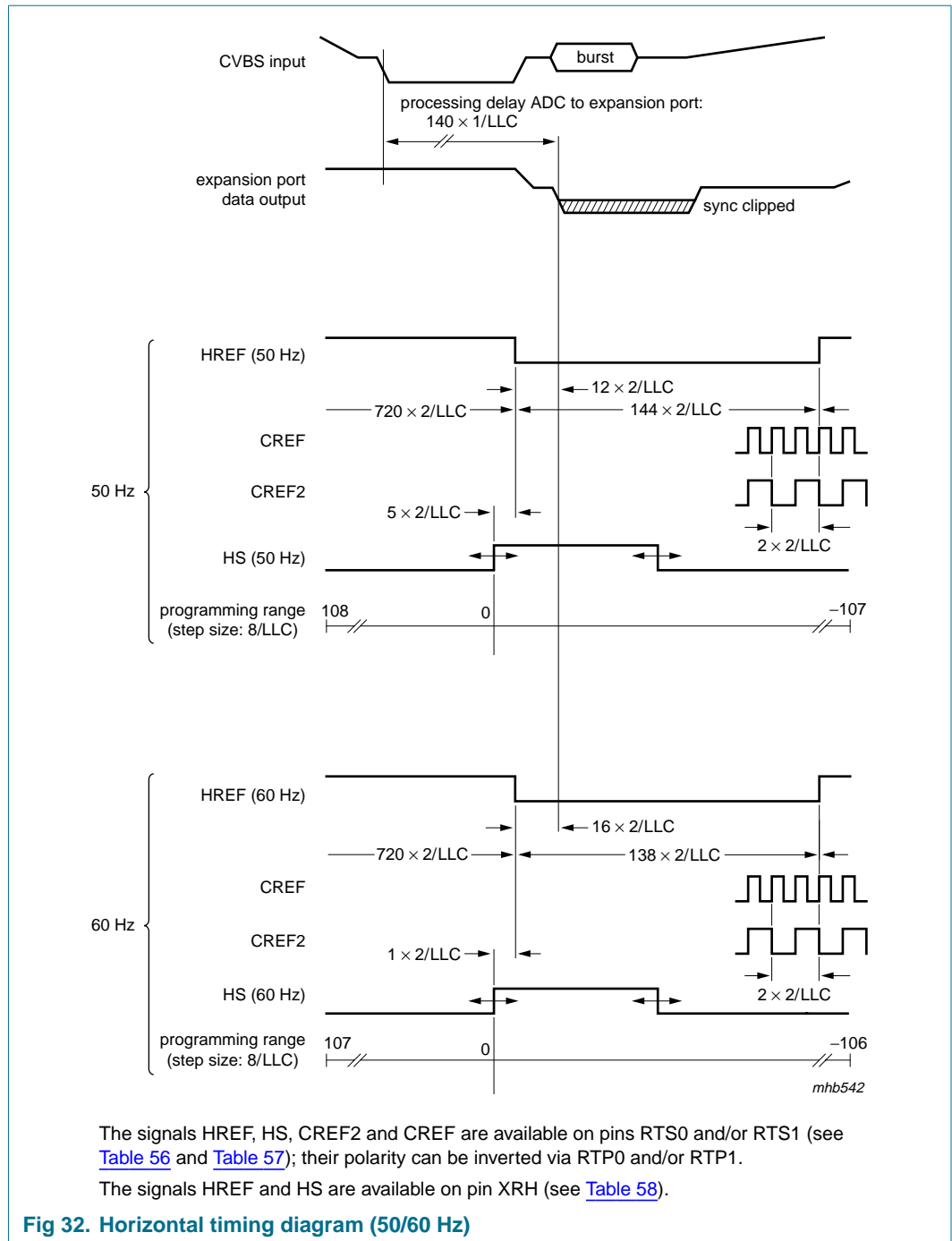

8.4 Scaler

The High Performance video Scaler (HPS) is based on the system as implemented in previous products, but with some aspects enhanced. Vertical upsampling is supported and the processing pipeline buffer capacity is enhanced, to allow more flexible video stream timing at the image port, discontinuous transfers, and handshake. The internal data flow from block to block is discontinuous dynamically, due to the scaling process.

The flow is controlled by internal data valid and data request flags (internal handshake signalling) between the sub-blocks; therefore the entire scaler acts as a pipeline buffer. Depending on the actual programmed scaling parameters the effective buffer can exceed to an entire line. The access/bandwidth requirements to the VGA frame buffer are reduced significantly.

The high performance video scaler in the SAF7118 has the following major blocks:

- Acquisition control (horizontal and vertical timer) and task handling (the region/field/frame based processing)
- Prescaler, for horizontal downscaling by an integer factor, combined with appropriate band limiting filters, especially anti-aliasing for CIF format
- Brightness, saturation, contrast control for scaled output data
- Line buffer, with asynchronous read and write, to support vertical upscaling (e.g. for videophone application, converting 240 into 288 lines, Y-C_B-C_R 4 : 2 : 2)
- Vertical scaling, with phase accurate Linear Phase Interpolation (LPI) for zoom and downscale, or phase accurate Accumulation Mode (ACM) for large downscaling ratios and better alias suppression
- Variable Phase Delay (VPD), operates as horizontal phase accurate interpolation for arbitrary non-integer scaling ratios, supporting conversion between square and rectangular pixel sampling
- Output formatter for scaled Y-C_B-C_R 4 : 2 : 2, Y-C_B-C_R 4 : 1 : 1 and Y only (format also used for raw data)
- FIFO, 32-bit wide, with 64 pixel capacity in Y-C_B-C_R formats
- Output interface, 8-bit or 16-bit (only if extended by H port) data pins wide, synchronous or asynchronous operation, with stream events on discrete pins, or coded in the data stream

The overall H and V zooming (HV_zoom) is restricted by the input/output data rate relationships. With a safety margin of 2 % for running in and running out, the maximum

$$\text{HV_zoom is equal to: } 0.98 \times \frac{T_{\text{input_field}} - T_{\text{v_blanking}}}{\text{in_pixel} \times \text{in_lines} \times \text{out_cycle_per_pix} \times T_{\text{out_clk}}}$$

For example:

1. Input from decoder: 50 Hz, 720 pixel, 288 lines, 16-bit data at 13.5 MHz data rate, 1 cycle per pixel; output: 8-bit data at 27 MHz, 2 cycles per pixel; the maximum

$$\text{HV_zoom is equal to: } 0.98 \times \frac{20 \text{ ms} - 24 \times 64 \mu\text{s}}{720 \times 288 \times 2 \times 37 \text{ ns}} = 1.18$$

2. Input from X port: 60 Hz, 720 pixel, 240 lines, 8-bit data at 27 MHz data rate (ITU 656), 2 cycles per pixel; output via I + H port: 16-bit data at 27 MHz clock, 1 cycle per pixel; the maximum HV_zoom is equal to:

$$0.98 \times \frac{16.666 \text{ ms} - 22 \times 64 \mu\text{s}}{720 \times 240 \times 1 \times 37 \text{ ns}} = 2.34$$

The video scaler receives its input signal from the video decoder or from the expansion port (X port). It gets 16-bit $Y-C_B-C_R$ 4 : 2 : 2 input data at a continuous rate of 13.5 MHz from the decoder. Discontinuous data stream can be accepted from the expansion port (X port), normally 8-bit wide ITU 656 such as $Y-C_B-C_R$ data, accompanied by a pixel qualifier on XDQ.

The input data stream is sorted into two data paths, one for luminance (or raw samples) and one for time-multiplexed chrominance C_B and C_R samples. An $Y-C_B-C_R$ 4 : 1 : 1 input format is converted to 4 : 2 : 2 for the horizontal prescaling and vertical filter scaling operation.

The scaler operation is defined by two programming pages A and B, representing two different tasks, that can be applied field alternating or to define two regions in a field (e.g. with different scaling range, factors and signal source during odd and even fields).

Each programming page contains control:

- For signal source selection and formats
- For task handling and trigger conditions
- For input and output acquisition window definition
- For H-prescaler, V-scaler and H-phase scaling

Raw VBI data is handled as a specific input format and needs its own programming page (equals own task).

In VBI pass through operation the processing of prescaler and vertical scaling has to be set to no-processing, however, the horizontal fine scaling VPD can be activated. Upscaling (oversampling, zooming), free of frequency folding, up to a factor of 3.5 can be achieved, as required by some software data slicing algorithms.

These raw samples are transported through the image port as valid data and can be output as Y only format. The lines are framed by SAV and EAV codes.

8.4.1 Acquisition control and task handling (subaddresses 80h, 90h, 91h, 94h to 9Fh and C4h to CFh)

The acquisition control receives horizontal and vertical synchronization signals from the decoder section or from the X port. The acquisition window is generated via pixel and line counters at the appropriate places in the data path. From X port only qualified pixels and lines (lines with qualified pixel) are counted.

The acquisition window parameters are as follows:

- Signal source selection regarding input video stream and formats from the decoder, or from X port (programming bits SCSRC[1:0] 91h[5:4] and FSC[2:0] 91h[2:0])

Remark: The input of raw VBI data from the internal decoder should be controlled via the decoder output formatter and the LCR registers; see [Section 8.3](#)

- Vertical offset defined in lines of the video source, parameter YO[11:0] 99h[3:0] 98h[7:0]
- Vertical length defined in lines of the video source, parameter YS[11:0] 9Bh[3:0] 9Ah[7:0]

- Vertical length defined in number of target lines, as a result of vertical scaling, parameter YD[11:0] 9Fh[3:0] 9Eh[7:0]
- Horizontal offset defined in number of pixels of the video source, parameter XO[11:0] 95h[3:0] 94h[7:0]
- Horizontal length defined in number of pixels of the video source, parameter XS[11:0] 97h[3:0] 96h[7:0]
- Horizontal destination size, defined in target pixels after fine scaling, parameter XD[11:0] 9Dh[3:0] 9Ch[7:0]

The source start offset (XO11 to XO0 and YO11 to YO0) opens the acquisition window, and the target size (XD11 to XD0 and YD11 to YD0) closes the window, however the window is cut vertically if there are less output lines than expected. The trigger events for the pixel and line counts are the horizontal and vertical reference edges as defined in subaddress 92h. The task handling is controlled by subaddress 90h; see [Section 8.4.1.2](#).

8.4.1.1 Input field processing

The trigger event for the field sequence detection from external signals (X port) are defined in subaddress 92h. From the X port the state of the scalers H reference signal at the time of the V reference edge is taken as field sequence identifier FID. For example, if the falling edge of the XRV input signal is the reference and the state of XRH input is logic 0 at that time, the detected field ID is logic 0.

The bits XFDV[92h[7]] and XFDH[92h[6]] define the detection event and state of the flag from the X port. For the default setting of XFDV and XFDH at '00' the state of the H-input at the falling edge of the V-input is taken.

The scaler directly gets a corresponding field ID information from the SAF7118 decoder path.

The FID flag is used to determine whether the first or second field of a frame is going to be processed within the scaler and it is used as trigger condition for the task handling (see bits STRC[1:0] 90h[1:0]).

According to ITU 656, when FID is at logic 0 means first field of a frame. To ease the application, the polarities of the detection results on the X port signals and the internal decoder ID can be changed via XFDH.

As the V-sync from the decoder path has a half line timing (due to the interlaced video signal), but the scaler processing only knows about full lines, during 1st fields from the decoder the line count of the scaler possibly shifts by one line, compared to the 2nd field. This can be compensated for by switching the V-trigger event, as defined by XDVO, to the opposite V-sync edge or by using the vertical scalers phase offsets. The vertical timing of the decoder can be seen in [Figure 30](#) and [Figure 31](#).

As the H and V reference events inside the ITU 656 data stream (from X port) and the real-time reference signals from the decoder path are processed differently, the trigger events for the input acquisition also have to be programmed differently.

Table 9: Processing trigger and start

XDV1 92h[5]	XDV0 92h[4]	XDH 92h[2]	Description
0	1	0	Internal decoder: The processing triggers at the falling edge of the V123 pulse [see Figure 30 (50 Hz) and Figure 31 (60 Hz)], and starts earliest with the rising edge of the decoder HREF at line number: 4/7 (50/60 Hz, 1st field), respectively 3/6 (50/60 Hz, 2nd field) (decoder count)
0	0	0	2/5 (50/60 Hz, 1st field), respectively 2/5 (50/60 Hz, 2nd field) (decoder count)
0	0	0	External ITU 656 stream: The processing starts earliest with SAV at line number 23 (50 Hz system), respectively line 20 (60 Hz system) (according to ITU 656 count)

8.4.1.2 Task handling

The task handler controls the switching between the two programming register sets. It is controlled by subaddresses 90h and C0h. A task is enabled via the global control bits TEA[80h[4]] and TEB[80h[5]].

The handler is then triggered by events, which can be defined for each register set.

In the event of a programming error the task handling and the complete scaler can be reset to the initial states by setting the software reset bit SWRST[88h[5]] to logic 0. Especially if the programming registers, related acquisition window and scale are reprogrammed while a task is active, a software reset **must** be performed after programming.

Contrary to the disabling/enabling of a task, which is evaluated at the end of a running task, when SWRST is at logic 0 it sets the internal state machines directly to their idle states.

The start condition for the handler is defined by bits STRC[1:0] 90h[1:0] and means: start immediately, wait for next V-sync, next FID at logic 0 or next FID at logic 1. The FID is evaluated, if the vertical and horizontal offsets are reached.

When RPTSK[90h[2]] is at logic 1 the actual running task is repeated (under the defined trigger conditions), before handing control over to the alternate task.

To support field rate reduction, the handler is also enabled to skip fields (bits FSKP[2:0] 90h[5:3]) before executing the task. A TOGGLE flag is generated (used for the correct output field processing), which changes state at the beginning of a task, every time a task is activated; examples are given in [Section 8.4.1.3](#).

Remarks:

- **To activate a task the start condition must be fulfilled and the acquisition window offsets must be reached.**

For example, in case of 'start immediately', and two regions are defined for one field, the offset of the lower region must be greater than (offset + length) of the upper region, if not, the actual counted H and V position at the end of the upper task is beyond the programmed offsets and the processing will 'wait for next V'.

- **Basically the trigger conditions are checked, when a task is activated.** It is important to realize, that they are not checked while a task is inactive. So you can not trigger to next logic 0 or logic 1 with overlapping offset and active video ranges between the tasks (e.g. task A STRC[1:0] = 2, YO[11:0] = 310 and task B STRC[1:0] = 3, YO[11:0] = 310 results in output field rate of $50\frac{2}{3}$ Hz).
- **After power-on or software reset (via SWRST[88h[5]]) task B gets priority over task A.**

8.4.1.3 Output field processing

As a reference for the output field processing, two signals are available for the back-end hardware.

These signals are the input field ID from the scaler source and a TOGGLE flag, which shows that an active task is used an odd (1, 3, 5...) or even (2, 4, 6...) number of times. Using a single or both tasks and reducing the field or frame rate with the task handling function, the TOGGLE information can be used to reconstruct an interlaced scaled picture at a reduced frame rate. The TOGGLE flag isn't synchronized to the input field detection, as it is only dependent on the interpretation of this information by the external hardware, whether the output of the scaler is processed correctly; see [Section 8.4.3](#).

With OFIDC = 0, the scalers input field ID is available as output field ID on bit D6 of SAV and EAV, respectively on pin IGP0 (IGP1), if FID output is selected.

When OFIDC[90h[6]] = 1, the TOGGLE information is available as output field ID on bit D6 of SAV and EAV, respectively on pin IGP0 (IGP1), if FID output is selected.

Additionally the bit D7 of SAV and EAV can be defined via CONLH[90h[7]]. CONLH[90h[7]] = 0 (default) sets D7 to logic 1, a logic 1 inverts the SAV/EAV bit D7. So it is possible to mark the output of both tasks by different SAV/EAV codes. This bit can also be seen as 'task flag' on pins IGP0 (IGP1), if TASK output is selected.

Table 10: Examples for field processing

Subject	Field sequence frame/field																				
	Example 1 [1]			Example 2 [2] [3]				Example 3 [2] [4] [5]						Example 4 [2] [4] [6]							
	1/1	1/2	2/1	1/1	1/2	2/1	2/2	1/1	1/2	2/1	2/2	3/1	3/2	1/1	1/2	2/1	2/2	3/1	3/2		
Processed by task	A	A	A	B	A	B	A	B	B	A	B	B	A	B	B	A	B	B	A	B	A
State of detected ITU 656 FID	0	1	0	0	1	0	1	0	1	0	1	0	1	0	1	0	1	0	1	0	1
TOGGLE flag	1	0	1	1	1	0	0	1	0	1	1	0	0	0 [7]	1	1	1 [7]	0	0		
Bit D6 of SAV/EAV byte	0	1	0	0	1	0	1	1	0	1	1	0	0	0 [7]	1	1	1 [7]	0	0		
Required sequence conversion at the vertical scaler [8]	UP↓ UP	LO↓ LO	UP↓ UP	UP↓ UP	LO↓ LO	UP↓ UP	LO↓ LO	UP↓ LO	LO↓ UP	UP↓ LO	LO↓ LO	UP↓ UP	LO↓ UP	UP↓ UP	LO↓ LO	UP↓ LO	LO↓ LO	UP↓ UP	LO↓ UP	LO↓ UP	
Output [9]	O	O	O	O	O	O	O	O	O	O	O	O	O	O	NO	O	O	NO	O	O	

[1] Single task every field; OFIDC = 0; subaddress 90h at 40h; TEB[80h[5]] = 0.

[2] Tasks are used to scale to different output windows, priority on task B after SWRST.

[3] Both tasks at 1/2 frame rate; OFIDC = 0; subaddresses 90h at 43h and C0h at 42h.

[4] In examples 3 and 4 the association between input FID and tasks can be flipped, dependent on which time the SWRST is de-asserted.

[5] Task B at 2/3 frame rate constructed from neighboring motion phases; task A at 1/3 frame rate of equidistant motion phases; OFIDC = 1; subaddresses 90h at 41h and C0h at 45h.

[6] Task A and B at 1/3 frame rate of equidistant motion phases; OFIDC = 1; subaddresses 90h at 41h and C0h at 49h.

[7] State of prior field.

[8] It is assumed that input/output FID = 0 (= upper lines); UP = upper lines; LO = lower lines.

[9] O = data output; NO = no output.

8.4.2 Horizontal scaling

The overall horizontal required scaling factor has to be split into a binary and a rational value according to the equation:

$$\text{H-scale ratio} = \frac{\text{output pixel}}{\text{input pixel}}$$

$$\text{H-scale ratio} = \frac{I}{\text{XPSC}[5:0]} \times \frac{1024}{\text{XSCY}[12:0]}$$

where the parameter of prescaler $\text{XPSC}[5:0] = 1$ to 63 and the parameter of VPD phase interpolation $\text{XSCY}[12:0] = 300$ to 8191 (0 to 299 are only theoretical values). For example, $\frac{1}{3.5}$ is to split in $\frac{1}{4} \times 1.14286$. The binary factor is processed by the prescaler, the arbitrary non-integer ratio is achieved via the variable phase delay VPD circuitry, called horizontal fine scaling. The latter calculates horizontally interpolated new samples with a 6-bit phase accuracy, which relates to less than 1 ns jitter for regular sampling scheme. Prescaler and fine scaler create the horizontal scaler of the SAF7118.

Using the accumulation length function of the prescaler ($\text{XACL}[5:0]$ A1h[5:0]), application and destination dependent (e.g. scale for display or for a compression machine), a compromise between visible bandwidth and alias suppression can be determined.

8.4.2.1 Horizontal prescaler (subaddresses A0h to A7h and D0h to D7h)

The prescaling function consists of an FIR anti-alias filter stage and an integer prescaler, which creates an adaptive prescale dependent low-pass filter to balance sharpness and aliasing effects.

The FIR prefilter stage implements different low-pass characteristics to reduce alias for downscales in the range of 1 to $\frac{1}{2}$. A CIF optimized filter is built-in, which reduces artefacts for CIF output formats (to be used in combination with the prescaler set to $\frac{1}{2}$ scale); see [Table 11](#).

The function of the prescaler is defined by:

- An integer prescaling ratio $\text{XPSC}[5:0]$ A0h[5:0] (equals 1 to 63), which covers the integer downscale range 1 to $\frac{1}{63}$
- An averaging sequence length $\text{XACL}[5:0]$ A1h[5:0] (equals 0 to 63); range 1 to 64
- A DC gain renormalization $\text{XDCG}[2:0]$ A2h[2:0]; 1 down to $\frac{1}{128}$
- The bit $\text{XC2_1}[A2h[3]]$, which defines the weighting of the incoming pixels during the averaging process:
 - $\text{XC2_1} = 0 \Rightarrow 1 + 1 \dots + 1 + 1$
 - $\text{XC2_1} = 1 \Rightarrow 1 + 2 \dots + 2 + 1$

The prescaler creates a prescale dependent FIR low-pass, with up to (64 + 7) filter taps. The parameter $\text{XACL}[5:0]$ can be used to vary the low-pass characteristic for a given integer prescale of $\frac{1}{\text{XPSC}[5:0]}$. The user can therefore decide between signal bandwidth (sharpness impression) and alias.

Equation for $\text{XPSC}[5:0]$ calculation is: $\text{XPSC}[5:0] = \text{lower integer of } \frac{N_{\text{pix_in}}}{N_{\text{pix_out}}}$

Where:

- The range is 1 to 63 (**value 0 is not allowed**)
- Npix_in = number of input pixel, and
- Npix_out = number of desired output pixel over the complete horizontal scaler

The use of the prescaler results in a XACL[5:0] and XC2_1 dependent gain amplification. The amplification can be calculated according to the equation:

$$\text{DC gain} = (\text{XC2_1} + 1) \times \text{XACL}[5:0] + (1 - \text{XC2_1})$$

It is recommended to use sequence lengths and weights, which results in a 2^N DC gain amplification, as these amplitudes can be re normalized by the XDCG[2:0] controlled $\frac{1}{2^N}$ shifter of the prescaler.

The renormalization range of XDCG[2:0] is 1, $\frac{1}{2}$ down to $\frac{1}{128}$.

Other amplifications have to be normalized by using the following BCS control circuitry. In these cases the prescaler has to be set to an overall gain of ≤ 1 , e.g. for an accumulation sequence of '1 + 1 + 1' (XACL[5:0] = 2 and XC2_1 = 0), XDCG[2:0] must be set to '010', this equals $\frac{1}{4}$ and the BCS has to amplify the signal to $\frac{4}{3}$ (SATN[7:0] and CONT[7:0] value = lower integer of $\frac{4}{3} \times 64$).

The use of XACL[5:0] is XPSC[5:0] dependent. XACL[5:0] must be $< 2 \times \text{XPSC}[5:0]$.

XACL[5:0] can be used to find a compromise between bandwidth (sharpness) and alias effects.

Remark: Due to bandwidth considerations XPSC[5:0] and XACL[5:0] can be chosen differently to the previously mentioned equations or [Table 12](#), as the H-phase scaling is able to scale in the range from zooming up by factor 3 to downscaling by a factor of $\frac{1024}{8191}$.

[Figure 35](#) and [Figure 36](#) show some resulting frequency characteristics of the prescaler.

[Table 12](#) shows the recommended prescaler programming. Other programming, other than given in [Table 12](#), may result in better alias suppression, but the resulting DC gain amplification needs to be compensated by the BCS control, according to the equation:

$$\text{CONT}[7:0] = \text{SATN}[7:0] = \text{low integer of } \frac{2^{\text{XDCG}[2:0]}}{\text{DC gain} \times 64}$$

Where:

- $2^{\text{XDCG}[2:0]} \geq \text{DC gain}$
- $\text{DC gain} = (\text{XC2_1} + 1) \times \text{XACL}[5:0] + (1 - \text{XC2_1})$

For example, if XACL[5:0] = 5, XC2_1 = 1, then the DC gain = 10 and the required XDCG[2:0] = 4.

The horizontal source acquisition timing and the prescaling ratio is identical for both the luminance path and chrominance path, but the FIR filter settings can be defined differently in the two channels.

Fade-in and fade-out of the filters is achieved by copying an original source sample each as first and last pixel after prescaling.

Figure 33 and Figure 34 show the frequency characteristics of the selectable FIR filters.

Table 11: FIR prefilter functions

PFUV[1:0] A2h[7:6] and PFY[1:0] A2h[5:4]	Luminance filter coefficients	Chrominance coefficients
00	bypassed	bypassed
01	1 2 1	1 2 1
10	-1 1 1.75 4.5 1.75 1 -1	3 8 10 8 3
11	1 2 2 2 1	1 2 2 2 1

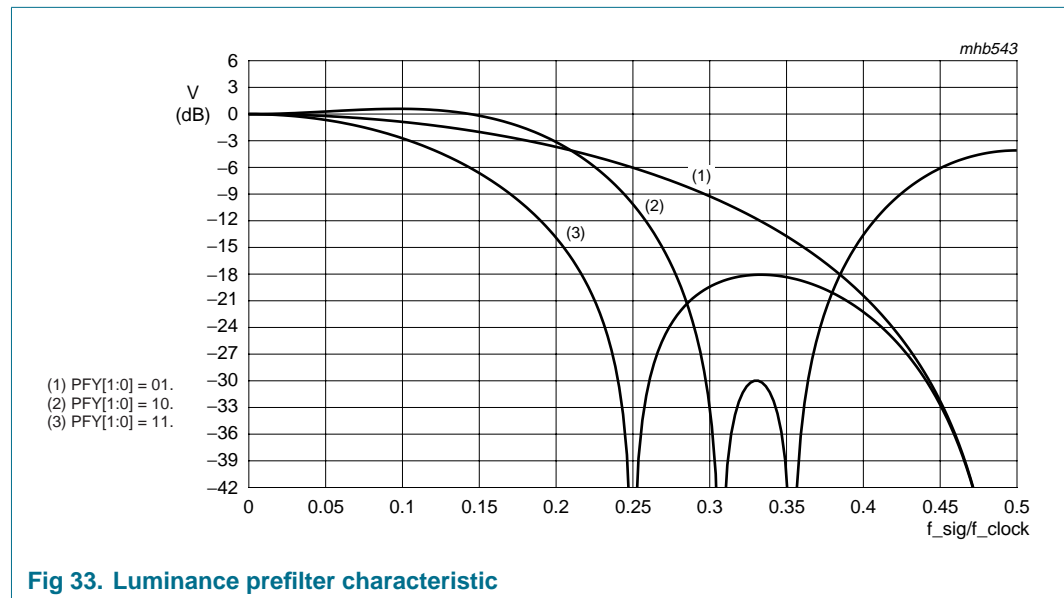

Fig 33. Luminance prefilter characteristic

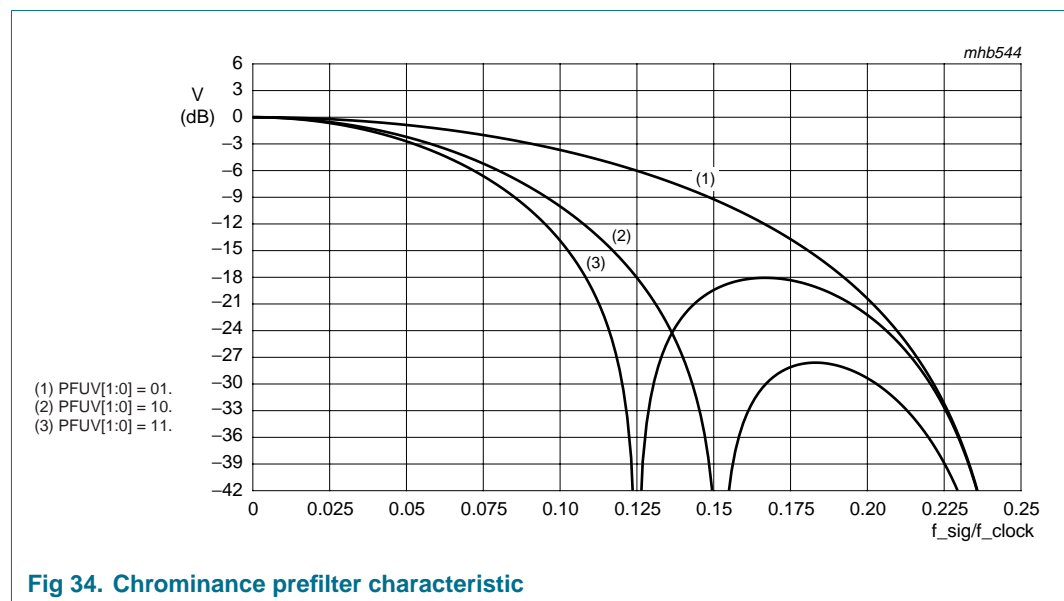
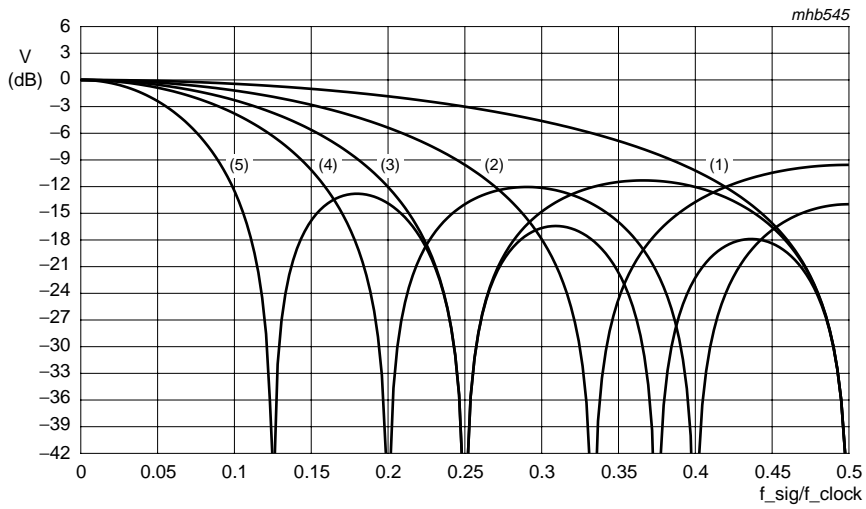
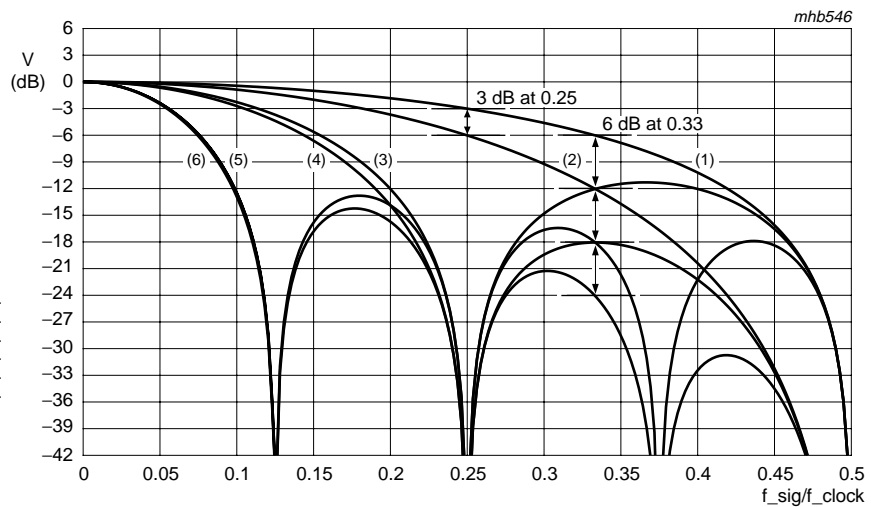

Fig 34. Chrominance prefilter characteristic



XC2_1 = 0; Zero's at $f = n \times \frac{1}{XACL + 1}$ with XACL = (1), (2), (3), (4) or (5)

Fig 35. Examples for prescaler filter characteristics: effect of increasing XACL[5:0]



- (1) XC2_1 = 0 and XACL[5:0] = 1.
- (2) XC2_1 = 1 and XACL[5:0] = 2.
- (3) XC2_1 = 0 and XACL[5:0] = 3.
- (4) XC2_1 = 1 and XACL[5:0] = 4.
- (5) XC2_1 = 0 and XACL[5:0] = 7.
- (6) XC2_1 = 1 and XACL[5:0] = 8.

Fig 36. Examples for prescaler filter characteristics: setting XC2_1 = 1

Table 12: XACL[5:0] example of usage

Prescale ratio	XPSC [5:0]	Recommended values						FIR prefilter PFY[1:0]/PFUV[1:0]
		For lower bandwidth requirements			For higher bandwidth requirements			
		XACL[5:0]	XC2_1	XDCG[2:0]	XACL[5:0]	XC2_1	XDCG[2:0]	
1	1	0	0	0	0	0	0	0 to 2
1/2	2	2	1	2	1	0	1	0 to 2
		(1 2 1) × 1/4 [1]			(1 1) × 1/2 [1]			
1/3	3	4	1	3	3	0	2	2
		(1 2 2 2 1) × 1/8 [1]			(1 1 1 1) × 1/4 [1]			
1/4	4	7	0	3	4	1	3	2
		(1 1 1 1 1 1 1 1) × 1/8 [1]			(1 2 2 2 1) × 1/8 [1]			
1/5	5	8	1	4	7	0	3	2
		(1 2 2 2 2 2 2 2 1) × 1/16 [1]			(1 1 1 1 1 1 1 1 1) × 1/8 [1]			
1/6	6	8	1	4	7	0	3	3
		(1 2 2 2 2 2 2 2 1) × 1/16 [1]			(1 1 1 1 1 1 1 1 1) × 1/8 [1]			
1/7	7	8	1	4	7	0	3	3
		(1 2 2 2 2 2 2 2 1) × 1/16 [1]			(1 1 1 1 1 1 1 1 1) × 1/8 [1]			
1/8	8	15	0	4	8	1	4	3
		(1 1 1 1 1 1 1 1 1 1 1 1 1 1 1 1) × 1/16 [1]			(1 2 2 2 2 2 2 2 1) × 1/16 [1]			
1/9	9	15	0	4	8	1	4	3
		(1 1 1 1 1 1 1 1 1 1 1 1 1 1 1 1) × 1/16 [1]			(1 2 2 2 2 2 2 2 1) × 1/16 [1]			
1/10	10	16	1	5	8	1	4	3
		(1 2 2 2 2 2 2 2 2 2 2 2 2 2 2 2 2 2 1) × 1/32 [1]			(1 2 2 2 2 2 2 2 1) × 1/16 [1]			
1/13	13	16	1	5	16	1	5	3
1/15	15	31	0	5	16	1	5	3
1/16	16	32	1	6	16	1	5	3
1/19	19	32	1	6	32	1	6	3
1/31	31	32	1	6	32	1	6	3
1/32	32	63	1	7	32	1	6	3
1/35	35	63	1	7	63	1	7	3

[1] Resulting FIR function.

8.4.2.2 Horizontal fine scaling (variable phase delay filter; subaddresses A8h to AFh and D8h to DFh)

The horizontal fine scaling (VPD) should operate at scaling ratios between 1/2 and 2 (0.8 and 1.6), but can also be used for direct scaling in the range from 1/7.999 to (theoretical) zoom 3.5 (restriction due to the internal data path architecture), without prescaler.

In combination with the prescaler a compromise between sharpness impression and alias can be found. This is signal source and application dependent.

For the luminance channel a filter structure with 10 taps is implemented, and for the chrominance a filter with 4 taps.

Luminance and chrominance scale increments (XSCY[12:0] A9h[4:0] A8h[7:0] and XSCC[12:0] ADh[4:0] ACh[7:0]) are defined independently, but must be set in a 2 : 1 relationship in the actual data path implementation. The phase offsets XPHY[7:0] AAh[7:0] and XPHC[7:0] AEh[7:0] can be used to shift the sample phases slightly. XPHY[7:0] and XPHC[7:0] covers the phase offset range $7.999T$ to $\frac{1}{32}T$. The phase offsets should also be programmed in a 2 : 1 ratio.

The underlying phase controlling DTO has a 13-bit resolution.

According the equations:

$$XSCY[12:0] = 1024 \times \frac{N_{\text{pix_in}}}{X_{\text{PSC}}[5:0]} \times \frac{I}{N_{\text{pix_out}}} \quad \text{and} \quad XSCC[12:0] = \frac{XSCY[12:0]}{2}$$

the VPD covers the scale range from 0.125 to zoom 3.5. VPD acts equivalent to a polyphase filter with 64 possible phases. In combination with the prescaler, it is possible to get very accurate samples from a highly anti-aliased integer downsampled input picture.

8.4.3 Vertical scaling

The vertical scaler of the SAF7118 consists of a line FIFO buffer for line repetition and the vertical scaler block, which implements the vertical scaling on the input data stream in 2 different operational modes from theoretical zoom by 64 down to icon size $\frac{1}{64}$. The vertical scaler is located between the BCS and horizontal fine scaler, so that the BCS can be used to compensate the DC gain amplification of the ACM mode (see [Section 8.4.3.2](#)) as the internal RAMs are only 8-bit wide.

8.4.3.1 Line FIFO buffer (subaddresses 91h, B4h and C1h, E4h)

The line FIFO buffer is a dual ported RAM structure for 768 pixels, with asynchronous write and read access. The line buffer can be used for various functions, but not all functions may be available simultaneously.

The line buffer can buffer a complete unscaled active video line or more than one shorter lines (only for non-mirror mode), for selective repetition for vertical zoom-up.

For zooming up 240 lines to 288 lines e.g., every fourth line is requested (read) twice from the vertical scaling circuitry for calculation.

For conversion of a 4 : 2 : 0 or 4 : 1 : 0 input sampling scheme (MPEG, video phone, Indeo YUV-9) to ITU like sampling scheme 4 : 2 : 2, the chrominance line buffer is read twice or four times, before being refilled again by the source. It has to be preserved by means of the input acquisition window definition, so that the processing starts with a line containing luminance and chrominance information for 4 : 2 : 0 and 4 : 1 : 0 input. The bits FSC[2:1] 91h[2:1] define the distance between the Y/C lines. In the event of 4 : 2 : 2 and 4 : 1 : 1 FSC2 and FSC1 have to be set to '00'.

The line buffer can also be used for mirroring, i.e. for flipping the image left to right, for the vanity picture in video phone applications (bit YMIR[B4h[4]]). In mirror mode only one active prescaled line can be held in the FIFO at a time.

The line buffer can be utilized as an excessive pipeline buffer for discontinuous and variable rate transfer conditions at the expansion port or image port.

8.4.3.2 Vertical scaler (subaddresses B0h to BFh and E0h to EFh)

Vertical scaling of any ratio from 64 (theoretical zoom) to $\frac{1}{63}$ (icon) can be applied.

The vertical scaling block consists of another line delay, and the vertical filter structure, that can operate in two different modes; Linear Phase Interpolation (LPI) and accumulation (ACM) mode. These are controlled by YMODE[B4h[0]]:

- **LPI mode:** In LPI mode (YMODE = 0) two neighboring lines of the source video stream are added together, but weighted by factors corresponding to the vertical position (phase) of the target output line relative to the source lines. This linear interpolation has a 6-bit phase resolution, which equals 64 intra line phases. It interpolates between two consecutive input lines only. LPI mode should be applied for scaling ratios around 1 (down to $\frac{1}{2}$), **it must be applied for vertical zooming**.
- **ACM mode:** The vertical Accumulation (ACM) mode (YMODE = 1) represents a vertical averaging window over multiple lines, sliding over the field. This mode also generates phase correct output lines. The averaging window length corresponds to the scaling ratio, resulting in an adaptive vertical low-pass effect, to greatly reduce aliasing artefacts. ACM can be applied for downscales only from ratio 1 down to $\frac{1}{64}$. ACM results in a scale dependent **DC gain amplification**, which has to be precorrected by the BCS control of the scaler part.

The phase and scale controlling DTO calculates in 16-bit resolution, controlled by parameters YSCY[15:0] B1h[7:0] B0h[7:0] and YSCC[15:0] B3h[7:0] B2h[7:0], continuously over the entire field. A start offset can be applied to the phase processing by means of the parameters YPY3[7:0] to YPY0[7:0] in BFh[7:0] to BCh[7:0] and YPC3[7:0] to YPC0[7:0] in BBh[7:0] to B8h[7:0]. The start phase covers the range of $\frac{255}{32}$ to $\frac{1}{32}$ lines offset.

By programming appropriate, opposite, vertical start phase values (subaddresses B8h to BFh and E8h to EFh) depending on odd or even field ID of the source video stream and A or B page cycle, frame ID conversion and field rate conversion are supported (i.e. de-interlacing, re-interlacing).

[Figure 37](#) and [Figure 38](#) and [Table 13](#) and [Table 14](#) describe the use of the offsets.

Remark: The vertical start phase, as well as scaling ratio are defined independently for the luminance and chrominance channel, but must be set to the same values in the actual implementation for accurate 4 : 2 : 2 output processing.

The vertical processing communicates on its input side with the line FIFO buffer. The scale related equations are:

- Scaling increment calculation for ACM and LPI mode, downscale and zoom:

$$YSCY[15:0] \text{ and } YSCC[15:0] = \text{lower integer of } \left(1024 \times \frac{N_{\text{line_in}}}{N_{\text{line_out}}} \right)$$

- BCS value to compensate DC gain in ACM mode (contrast and saturation have to be set): CONT[7:0] A5h[7:0] respectively SATN[7:0] A6h[7:0]

$$= \text{lower integer of } \left(\frac{N_{\text{line_out}}}{N_{\text{line_in}}} \times 64 \right), \text{ or } = \text{lower integer of } \left(\frac{1024}{YSCY[15:0]} \times 64 \right)$$

8.4.3.3 Use of the vertical phase offsets

As described in Section 8.4.1.3, the scaler processing may run randomly over the interlaced input sequence. Additionally the interpretation and timing between ITU 656 field ID and real-time detection by means of the state of H-sync at the falling edge of V-sync may result in different field ID interpretation.

A vertically scaled interlaced output also gets a larger vertical sampling phase error, if the interlaced input fields are processed, without regard to the actual scale at the starting point of operation Figure 37.

For correct interlaced processing the vertical scaler must be used with respect to the interlace properties of the input signal and, if required, for conversion of the field sequences.

Four events should be considered, they are illustrated in Figure 38.

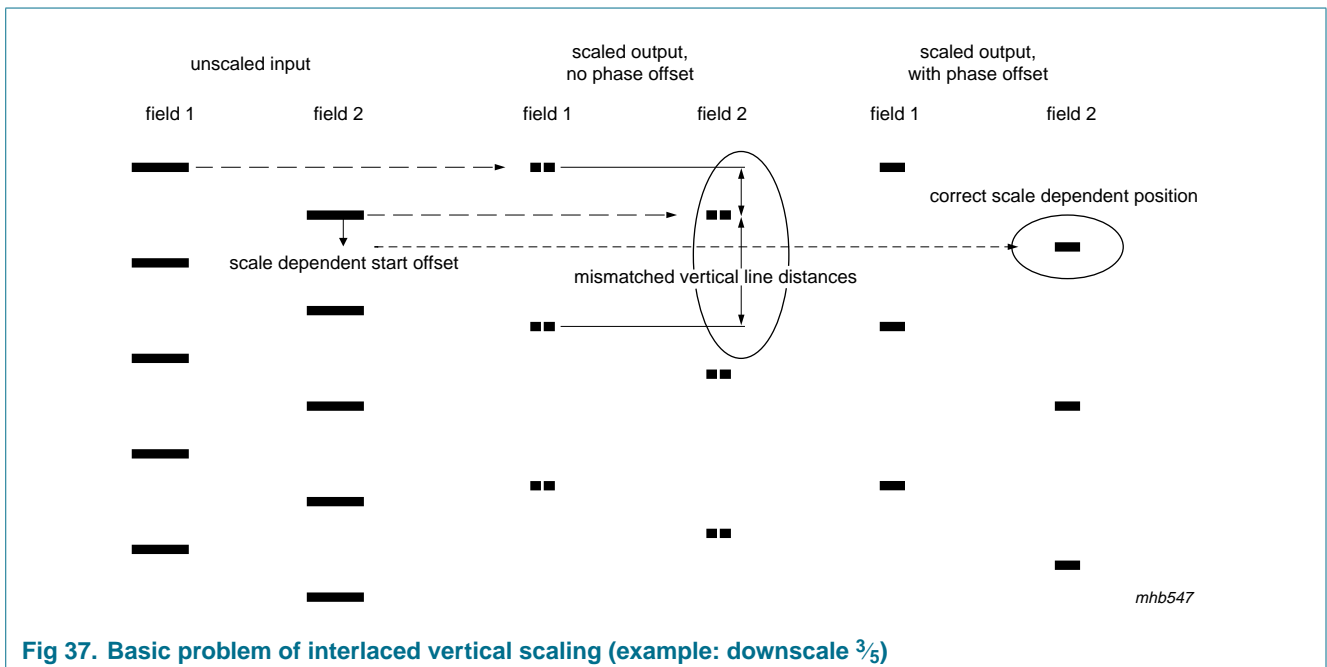
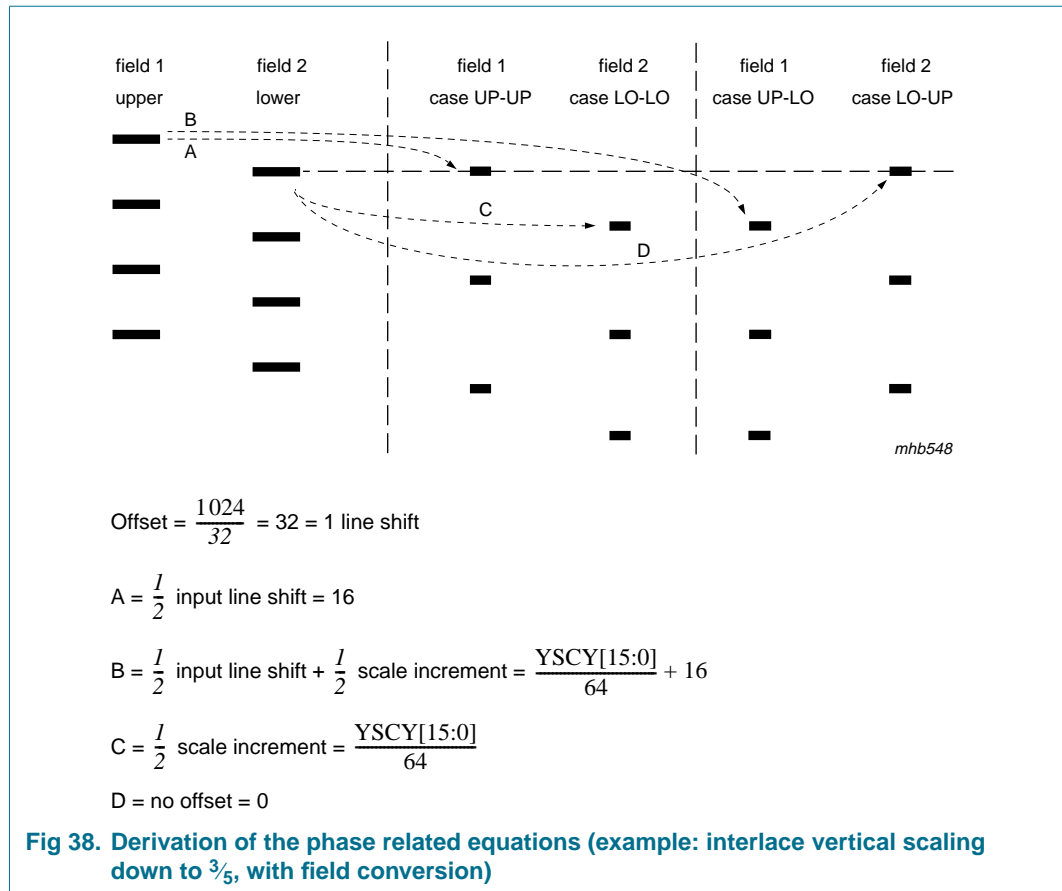

Fig 37. Basic problem of interlaced vertical scaling (example: downscale 3/5)



In [Table 13](#) and [Table 14](#) PHO is a usable common phase offset.

It should be noted that the equations of [Figure 38](#) produce an interpolated output, also for the unscaled case, as the geometrical reference position for all conversions is the position of the first line of the lower field; see [Table 13](#).

If there is no need for UP-LO and LO-UP conversion and the input field ID is the reference for the back-end operation, then it is UP-LO = UP-UP and LO-UP = LO-LO and the $\frac{1}{2}$ line phase shift (PHO + 16) that can be skipped. This case is listed in [Table 14](#).

The SAF7118 supports 4 phase offset registers per task and component (luminance and chrominance). The value of 20h represents a phase shift of one line.

The registers are assigned to the following events; e.g. subaddresses B8h to BBh:

- B8h: 00 = input field ID 0, task status bit D0 (toggle status; see [Section 8.4.1.3](#))
- B9h: 01 = input field ID 0, task status bit D1
- BAh: 10 = input field ID 1, task status bit D0
- BBh: 11 = input field ID 1, task status bit D1

Depending on the input signal (interlaced or non-interlaced) and the task processing 50 Hz or field reduced processing with one or two tasks (see examples in [Section 8.4.1.3](#)), other combinations may also be possible, but the basic equations are the same.

Table 13: Examples for vertical phase offset usage: global equations

Input field under processing	Output field interpretation	Used abbreviation	Equation for phase offset calculation (decimal values)
Upper input lines	upper output lines	UP-UP	PHO + 16
Upper input lines	lower output lines	UP-LO	$PHO + \frac{YSCY[15:0]}{64} + 16$
Lower input lines	upper output lines	LO-UP	PHO
Lower input lines	lower output lines	LO-LO	$PHO + \frac{YSCY[15:0]}{64}$

Table 14: Vertical phase offset usage; assignment of the phase offsets

Detected input field ID	Task status bit	Vertical phase offset	Case	Equation to be used
0 = upper lines	0	YPY0[7:0] and YPC0[7:0]	case 1 [1]	UP-UP (PHO)
			case 2 [2]	UP-UP
			case 3 [3]	UP-LO
0 = upper lines	1	YPY1[7:0] and YPC1[7:0]	case 1	UP-UP (PHO)
			case 2	UP-LO
			case 3	UP-UP
1 = lower lines	0	YPY2[7:0] and YPC2[7:0]	case 1	$LO-LO \left(PHO + \frac{YSCY[15:0]}{64} - 16 \right)$
			case 2	LO-UP
			case 3	LO-LO
1 = lower lines	1	YPY3[7:0] and YPC3[7:0]	case 1	$LO-LO \left(PHO + \frac{YSCY[15:0]}{64} - 16 \right)$
			case 2	LO-LO
			case 3	LO-UP

- [1] Case 1: OFIDC[90h[6]] = 0; scaler input field ID as output ID; back-end interprets output field ID at logic 0 as upper output lines.
- [2] Case 2: OFIDC[90h[6]] = 1; task status bit as output ID; back-end interprets output field ID at logic 0 as upper output lines.
- [3] Case 3: OFIDC[90h[6]] = 1; task status bit as output ID; back-end interprets output field ID at logic 1 as upper output lines.

8.5 VBI data decoder and capture (subaddresses 40h to 7Fh)

The SAF7118 contains a versatile VBI data decoder.

The implementation and programming model is in accordance with the VBI data slicer built into the multimedia video data acquisition circuit SAA5284.

The circuitry recovers the actual clock phase during the clock run-in period, slices the data bits with the selected data rate, and groups them into bytes. The result is buffered into a dedicated VBI data FIFO with a capacity of 2×56 bytes (2×14 Dwords). The clock frequency, signal source, field frequency and accepted error count must be defined in subaddress 40h.

The supported VBI data standards are shown in [Table 15](#).

For lines 2 to 24 of a field, per VBI line, 1 of 16 standards can be selected (LCR24_[7:0] to LCR2_[7:0] in 57h[7:0] to 41h[7:0]: $23 \times 2 \times 4$ bit programming bits).

The definition for line 24 is valid for the rest of the corresponding field, normally no text data (video data) should be selected there (LCR24_[7:0] = FFh) to stop the activity of the VBI data slicer during active video.

To adjust the slicers processing to the input signal source, there are offsets in the horizontal and vertical direction available: parameters HOFF[10:0] 5Bh[2:0] 59h[7:0], VOFF[8:0] 5Bh[4] 5Ah[7:0] and FOFF[5Bh[7]].

Contrary to the scalers counting, the slicers offsets define the position of the H and V trigger events related to the processed video field. The trigger events are the falling edge of HREF and the falling edge of V123 from the decoder processing part.

The relationship of these programming values to the input signal and the recommended values are given in [Figure 28](#) and [Figure 29](#).

Table 15: Data types supported by the data slicer block

DT[3:0] 62h[3:0]	Standard type	Data rate (Mbit/s)	Framing Code (FC)	FC window	Hamming check
0000	teletext EuroWST, CCST	6.9375	27h	WST625	always
0001	European closed caption	0.500	001	CC625	
0010	VPS	5	9951h	VPS	
0011	wide screen signalling bits	5	1E 3C1Fh	WSS	
0100	US teletext (WST)	5.7272	27h	WST525	always
0101	US closed caption (line 21)	0.503	001	CC525	
0110	(video data selected)	5	none	disable	
0111	(raw data selected)	5	none	disable	
1000	teletext	6.9375	programmable	general text	optional
1001	VITC/EBU time codes (Europe)	1.8125	programmable	VITC625	
1010	VITC/SMPTE time codes (USA)	1.7898	programmable	VITC525	
1011	reserved				
1100	US NABTS	5.7272	programmable	NABTS	optional

Table 15: Data types supported by the data slicer block...continued

DT[3:0] 62h[3:0]	Standard type	Data rate (Mbit/s)	Framing Code (FC)	FC window	Hamming check
1101	MOJI (Japanese)	5.7272	programmable (A7h)	Japtext	
1110	Japanese format switch (L20/22)	5	programmable	open	
1111	no sliced data transmitted (video data selected)	5	none	disable	

8.6 Image port output formatter (subaddresses 84h to 87h)

The output interface consists of a FIFO for video and for sliced text data, an arbitration circuit, which controls the mixed transfer of video and sliced text data over the I port and a decoding and multiplexing unit, which generates the 8-bit or 16-bit wide output data stream and the accompanied reference and supporting information.

The clock for the output interface can be derived from an internal clock, decoder, expansion port, or an externally provided clock which is appropriate for e.g. VGA and frame buffer. The clock can be up to 33 MHz. The scaler provides the following video related timing reference events (signals), which are available on pins as defined by subaddresses 84h and 85h:

- Output field ID
- Start and end of vertical active video range
- Start and end of active video line
- Data qualifier or gated clock
- Actually activated programming page (if CONLH is used)
- Threshold controlled FIFO filling flags (empty, full and filled)
- Sliced data marker

The discontinuous data stream at the scaler output is accompanied by a data valid flag (or data qualifier), or is transported via a gated clock. Clock cycles with invalid data on the I port data bus (including the HPD pins in 16-bit output mode) are marked with code 00h.

The output interface also arbitrates the transfer between scaled video data and sliced text data over the I port output.

The bits VITX1 and VITX0 (subaddress 86h) are used to control the arbitration.

As a further operation the serialization of the internal 32-bit Dwords to 8-bit or optional 16-bit output, as well as the insertion of the extended ITU 656 codes (SAV/EAV for video data, ANC or SAV/EAV codes for sliced text data) are done here.

For handshake with the VGA controller, or other memory or bus interface circuitry, programmable FIFO flags are provided; see [Section 8.6.2](#).

8.6.1 Scaler output formatter (subaddresses 93h and C3h)

The output formatter organizes the packing into the output FIFO. The following formats are available: Y-C_B-C_R 4 : 2 : 2, Y-C_B-C_R 4 : 1 : 1, Y-C_B-C_R 4 : 2 : 0, Y-C_B-C_R 4 : 1 : 0 and Y only (e.g. for raw samples). The formatting is controlled by FSI[2:0] 93h[2:0], FOI[1:0] 93h[4:3] and FYSK[93h[5]].

The data formats are defined on Dwords, or multiples, and are similar to the video formats as recommended for PCI multimedia applications (compares to SAA7146A), but planar formats are not supported.

FSI[2:0] defines the horizontal packing of the data, FOI[1:0] defines how many Y only lines are expected, before a Y/C line will be formatted. If FYSK is set to logic 0 preceding Y only lines will be skipped, and the output will always start with a Y/C line.

Additionally the output formatter limits the amplitude range of the video data (controlled by ILLV[85h[5]]); see [Table 18](#).

Table 16: Byte stream for different output formats

Output format	Byte sequence for 8-bit output modes													
Y-C _B -C _R 4 : 2 : 2	C _{B0}	Y0	C _{R0}	Y1	C _{B2}	Y2	C _{R2}	Y3	C _{B4}	Y4	C _{R4}	Y5	C _{B6}	Y6
Y-C _B -C _R 4 : 1 : 1	C _{B0}	Y0	C _{R0}	Y1	C _{B4}	Y2	C _{R4}	Y3	Y4	Y5	Y6	Y7	C _{B8}	Y8
Y only	Y0	Y1	Y2	Y3	Y4	Y5	Y6	Y7	Y8	Y9	Y10	Y11	Y12	Y13

Table 17: Explanation to [Table 16](#)

Name	Explanation
C _{Bn}	C _B (B – Y) color difference component, pixel number n = 0, 2, 4 to 718
Y _n	Y (luminance) component, pixel number n = 0, 1, 2, 3 to 719
C _{Rn}	C _R (R – Y) color difference component, pixel number n = 0, 2, 4 to 718

Table 18: Limiting range on I port

Limit step ILLV[85h[5]]	Valid range		Suppressed codes (hexadecimal value)	
	Decimal value	Hexadecimal value	Lower range	Upper range
0	1 to 254	01 to FE	00	FF
1	8 to 247	08 to F7	00 to 07	F8 to FF

8.6.2 Video FIFO (subaddress 86h)

The video FIFO at the scaler output contains 32 Dwords. That corresponds to 64 pixels in 16-bit Y-C_B-C_R 4 : 2 : 2 format. But as the entire scaler can act as a pipeline buffer, the actual available buffer capacity for the image port is much higher, and can exceed beyond a video line.

The image port, and the video FIFO, can operate with the video source clock (synchronous mode) or with an externally provided clock (asynchronous and burst mode), as appropriate for the VGA controller or attached frame buffer.

The video FIFO provides 4 internal flags, reporting to what extent the FIFO is actually filled.

These are:

- The FIFO Almost Empty (FAE) flag
- The FIFO Combined Flag (FCF) or FIFO filled, which is set at almost full level and reset, with hysteresis, only after the level crosses below the almost empty mark
- The FIFO Almost Full (FAF) flag
- The FIFO Overflow (FOVL) flag

The trigger levels for FAE and FAF are programmable by FFL[1:0] 86h[3:2] (16, 24, 28, full) and FEL[1:0] 86h[1:0] (16, 8, 4, empty).

The state of this flag can be seen on pins IGP0 or IGP1. The pin mapping is defined by subaddresses 84h and 85h; see [Section 9.6](#).

8.6.3 Text FIFO

The data of the internal VBI data slicer is collected in the text FIFO before the transmission over the I port is requested (normally before the video window starts). It is partitioned into two FIFO sections. A complete line is filled into the FIFO before a data transfer is requested. So normally, one line of text data is ready for transfer, while the next text line is collected. Thus sliced text data is delivered as a block of qualified data, without any qualification gaps in the byte stream of the I port.

The decoded VBI data is collected in the dedicated VBI data FIFO. After the capture of a line has been completed, the FIFO can be streamed through the image port, preceded by a header, giving line number and standard.

The VBI data period can be signalled via the sliced data flag on pin IGP0 or IGP1. The decoded VBI data is lead by the ITU ancillary data header (DID[5:0] 5Dh[5:0] at value < 3Eh) or by SAV/EAV codes selectable by DID[5:0] at value 3Eh or 3Fh. Pin IGP0 or IGP1 is set if the first byte of the ANC header is valid on the I port bus. It is reset if an SAV occurs. So it may frame multiple lines of text data output, in the event that the video processing starts with a distance of several video lines to the region of text data. Valid sliced data from the text FIFO is available on the I port as long as the IGP0 or IGP1 flag is set and the data qualifier is active on pin IDQ.

The decoded VBI data is presented in two different data formats, controlled by bit RECODE.

- RECODE = 1: values 00h and FFh will be recoded to even parity values 03h and FCh
- RECODE = 0: values 00h and FFh may occur in the data stream as detected

8.6.4 Video and text arbitration (subaddress 86h)

Sliced text data and scaled video data are transferred over the same bus, the I port. The mixed transfer is controlled by an arbitration circuit.

If the video data is transferred without any interrupt and the video FIFO does not need to buffer any output pixel, the text data is inserted after the end of a scaled video line, normally during the blanking interval of the video.

8.6.5 Data stream coding and reference signal generation (subaddresses 84h, 85h and 93h)

As H and V reference signals are logic 1, active gate signals are generated, which frame the transfer of the valid output data. As an alternative to the gates, H and V trigger pulses are generated on the rising edges of the gates.

Due to the dynamic FIFO behavior of the complete scaler path, the output signal timing has no fixed timing relationship to the real-time input video stream. So fixed propagation delays, in terms of clock cycles, related to the analog input cannot be defined.

The data stream is accompanied by a data qualifier. Additionally invalid data cycles are marked with code 00h.

If ITU 656 like codes are not required, they can be suppressed in the output stream.

As a further option, it is possible to provide the scaler with an external gating signal on pin ITRDY. Thereby making it possible to hold the data output for a certain time and to get valid output data in bursts of a guaranteed length.

The sketched reference signals and events can be mapped to the I port output pins IDQ, IGPH, IGPV, IGP0 and IGP1. For flexible use the polarities of all the outputs can be modified. The default polarity for the qualifier and reference signals is logic 1 (active).

[Table 19](#) shows the relevant and supported SAV and EAV coding.

Table 19: SAV/EAV codes on I port

Event description	SAV/EAV codes on I port [1] (hexadecimal)				Comment
	MSB [2] of SAV/EAV byte = 0		MSB [2] of SAV/EAV byte = 1		
	Field ID = 0	Field ID = 1	Field ID = 0	Field ID = 1	
Next pixel is FIRST pixel of any active line	0E	49	80	C7	HREF = active; VREF = active
Previous pixel was LAST pixel of any active line, but not the last	13	54	9D	DA	HREF = inactive; VREF = active
Next pixel is FIRST pixel of any V-blanking line	25	62	AB	EC	HREF = active; VREF = inactive
Previous pixel was LAST pixel of the last active line or of any V-blanking line	38	7F	B6	F1	HREF = inactive; VREF = inactive
No valid data, don't capture and don't increment pointer	00				IDQ pin inactive

[1] The leading byte sequence is: FFh-00h-00h.

[2] The MSB of the SAV/EAV code byte is controlled by:

- a) Scaler output data: task A \Rightarrow MSB = $\overline{\text{CONLH}}[90\text{h}[7]]$; task B \Rightarrow MSB = $\overline{\text{CONLH}}[C0\text{h}[7]]$.
- b) VBI data slicer output data: DID[5:0] 5Dh[5:0] = 3Eh \Rightarrow MSB = 1; DID[5:0] 5Dh[5:0] = 3Fh \Rightarrow MSB = 0

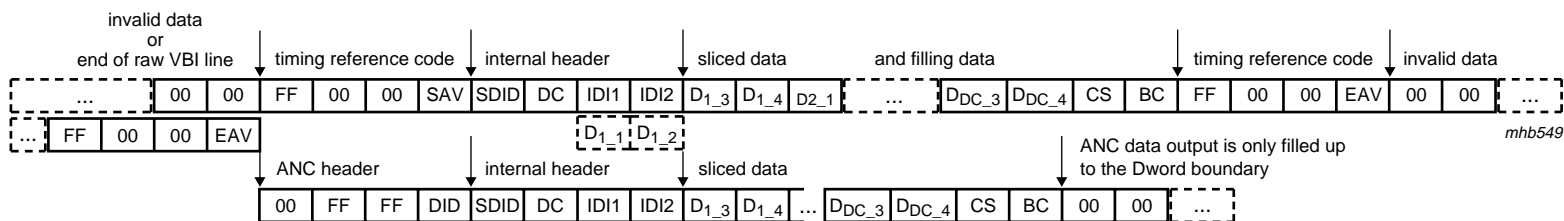

ANC header active for DID (subaddress 5Dh) < 3Eh

Fig 39. Sliced data formats on the I port in 8-bit mode

Table 20: Explanation to Figure 39

Name	Explanation
SAV	start of active data; see Table 21
SDID	sliced data identification: NEP [1] , EP [2] , SDID5 to SDID0, freely programmable via I ² C-bus subaddress 5Eh, D5 to D0, e.g. to be used as source identifier
DC	Dword count: NEP [1] , EP [2] , DC5 to DC0. DC describes the number of succeeding 32-bit words: For SAV/EAV mode DC is fixed to 11 Dwords (byte value 4Bh) For ANC mode it is: $DC = \frac{1}{4}(C + n)$, where C = 2 (the two data identification bytes IDI1 and IDI2) and n = number of decoded bytes according to the chosen text standard It should be noted that the number of valid bytes inside the stream can be seen in the BC byte.
IDI1	internal data identification 1: OP [3] , FID (field 1 = 0, field 2 = 1), LineNumber8 to LineNumber3 = Dword 1 byte 1; see Table 21
IDI2	internal data identification 2: OP [3] , LineNumber2 to LineNumber0, DataType3 to DataType0 = Dword 1 byte 2; see Table 21
D _{n_m}	Dword number n , byte number m
D _{DC_4}	last Dword byte 4; remark: for SAV/EAV framing DC is fixed to 0Bh, missing data bytes are filled up; the fill value is A0h
CS	the check sum byte, the check sum is accumulated from the SAV (respectively DID) byte to the D _{DC_4} byte
BC	number of valid sliced bytes counted from the IDI1 byte
EAV	end of active data; see Table 21

[1] Inverted EP (bit D7); for EP see [Table note 2](#).

[2] Even parity (bit D6) of bits D5 to D0.

[3] Odd parity (bit D7) of bits D6 to D0.

Table 21: Bytes stream of the data slicer

Nick name	Comment	D7	D6	D5	D4	D3	D2	D1	D0
DID, SAV, EAV	subaddress 5Dh = 00h	NEP [1]	EP [2]	0	1	0	FID [3]	I1 [4]	I0 [4]
	subaddress 5Dh D5 = 1	NEP [1]	EP [2]	0	D4[5Dh]	D3[5Dh]	D2[5Dh]	D1[5Dh]	D0[5Dh]
	subaddress 5Dh D5 = 3Eh [5]	1	FID [3]	V [6]	H [7]	P3	P2	P1	P0
	subaddress 5Dh D5 = 3Fh [5]	0	FID [3]	V [6]	H [7]	P3	P2	P1	P0
SDID	programmable via subaddress 5Eh	NEP [1]	EP [2]	D5[5Eh]	D4[5Eh]	D3[5Eh]	D2[5Eh]	D1[5Eh]	D0[5Eh]
DC [8]		NEP [1]	EP [2]	DC5	DC4	DC3	DC2	DC1	DC0
IDI1		OP [9]	FID [3]	LN8 [10]	LN7 [10]	LN6 [10]	LN5 [10]	LN4 [10]	LN3 [10]
IDI2		OP [9]	LN2 [10]	LN1 [10]	LN0 [10]	DT3 [11]	DT2 [11]	DT1 [11]	DT0 [11]
CS	check sum byte	$\overline{CS6}$	CS6	CS5	CS4	CS3	CS2	CS1	CS0
BC	valid byte count	OP [9]	0	CNT5	CNT4	CNT3	CNT2	CNT1	CNT0

- [1] NEP = inverted EP; for EP see [Table note 2](#).
- [2] EP = even parity of bits D5 to D0.
- [3] FID = 0: field 1; FID = 1: field 2.
- [4] I1 = 0 and I0 = 0: before line 1; I1 = 0 and I0 = 1: lines 1 to 23; I1 = 1 and I0 = 0: after line 23; I1 = 1 and I0 = 1: line 24 to end of field.
- [5] Subaddress 5Dh at 3Eh and 3Fh are used for ITU 656 like SAV/EAV header generation; recommended value.
- [6] V = 0: active video; V = 1: blanking.
- [7] H = 0: start of line; H = 1: end of line.
- [8] DC = data count in Dwords according to the data type.
- [9] OP = odd parity of bits D6 to D0.
- [10] LN = line number.
- [11] DT = data type according to table.

8.7 Audio clock generation (subaddresses 30h to 3Fh)

The SAF7118 incorporates the generation of a field-locked audio clock as an auxiliary function for video capture. An audio sample clock, that is locked to the field frequency, ensures that there is always the same predefined number of audio samples associated with a field, or a set of fields. This ensures synchronous playback of audio and video after digital recording (e.g. capture to hard disk), MPEG or other compression, or non-linear editing.

8.7.1 Master audio clock

The audio clock is synthesized from the same crystal frequency as the line-locked video clock is generated. The master audio clock is defined by the parameters:

- Audio master Clocks Per Field, ACPF[17:0] 32h[1:0] 31h[7:0] 30h[7:0] according to the equation: $ACPF[17:0] = \text{round}\left(\frac{\text{audio frequency}}{\text{field frequency}}\right)$
- Audio master Clocks Nominal Increment, ACNI[21:0] 36h[5:0] 35h[7:0] 34h[7:0] according to the equation: $ACNI[21:0] = \text{round}\left(\frac{\text{audio frequency}}{\text{crystal frequency}} \times 2^{23}\right)$

See [Table 22](#) for examples.

Remark: For standard applications the synthesized audio clock AMCLK can be used directly as master clock and as input clock for port AMXCLK (short cut) to generate ASCLK and ALRCLK. For high-end applications it is recommended to use an external analog PLL circuit to enhance the performance of the generated audio clock.

Table 22: Programming examples for audio master clock generation

XTALO (MHz)	Field (Hz)	ACPF		ACNI	
		Decimal	Hex	Decimal	Hex
AMCLK = 256 × 48 kHz (12.288 MHz)					
32.11	50	245760	3 C000	3210190	30 FBCE
	59.94	205005	3 20CD	3210190	30 FBCE
24.576	50	-	-	-	-
	59.94	-	-	-	-
AMCLK = 256 × 44.1 kHz (11.2896 MHz)					
32.11	50	225792	3 7200	2949362	2D 00F2
	59.94	188348	2 DFBC	2949362	2D 00F2
24.576	50	225792	3 7200	3853517	3A CCCD
	59.94	188348	2 DFBC	3853517	3A CCCD
AMCLK = 256 × 32 kHz (8.192 MHz)					
32.11	50	163840	2 8000	2140127	20 A7DF
	59.94	136670	2 15DE	2140127	20 A7DF
24.576	50	163840	2 8000	2796203	2A AAAB
	59.94	136670	2 15DE	2796203	2A AAAB

8.7.2 Signals ASCLK and ALRCLK

Two binary divided signals ASCLK and ALRCLK are provided for slower serial digital audio signal transmission and for channel-select. The frequencies of these signals are defined by the following parameters:

- SDIV[5:0] 38h[5:0] according to the equation: $f_{ASCLK} = \frac{f_{AMXCLK}}{(SDIV + 1) \times 2} \Rightarrow$

$$SDIV[5:0] = \frac{f_{AMXCLK}}{2f_{ASCLK}} - 1$$

- LRDIV[5:0] 39h[5:0] according to the equation: $f_{ALRCLK} = \frac{f_{ASCLK}}{LRDIV \times 2} \Rightarrow$

$$LRDIV[5:0] = \frac{f_{ASCLK}}{2f_{ALRCLK}}$$

See [Table 23](#) for examples.

Table 23: Programming examples for ASCLK/ALRCLK clock generation

AMXCLK (MHz)	ASCLK (kHz)	SDIV		ALRCLK (kHz)	LRDIV	
		Decimal	Hex		Decimal	Hex
12.288	1536	3	03	48	16	10
	768	7	07		8	08
11.2896	1411.2	3	03	44.1	16	10
	2822.4	1	01		32	10
8.192	1024	3	03	32	16	10
	2048	1	01		32	10

8.7.3 Other control signals

Further control signals are available to define reference clock edges and vertical references; see [Table 24](#).

Table 24: Control signals for reference clock edges and vertical references

Signal	Description
APLL[3Ah[3]]	Audio PLL mode 0 = PLL closed 1 = PLL open
AMVR[3Ah[2]]	Audio Master clock Vertical Reference 0 = internal V 1 = external V
LRPH[3Ah[1]]	ALRCLK phase 0 = invert ASCLK, ALRCLK edges triggered by falling edge of ASCLK 1 = don't invert ASCLK, ALRCLK edges triggered by rising edge of ASCLK
SCPH[3Ah[0]]	ASCLK phase 0 = invert AMXCLK, ASCLK edges triggered by falling edge of AMXCLK 1 = don't invert AMXCLK, ASCLK edges triggered by rising edge of AMXCLK

9. Input/output interfaces and ports

The SAF7118 has 5 different I/O interfaces:

- Analog video input interface, for analog CVBS and/or Y and C input signals and/or component video signals
- Audio clock port
- Digital real-time signal port (RT port)
- Digital video expansion port (X port), for unscaled digital video input and output
- Digital image port (I port) for scaled video data output and programming
- Digital host port (H port) for extension of the image port or expansion port from 8-bit to 16-bit

9.1 Analog terminals

The SAF7118 has 16 analog inputs AI41 to AI44, AI31 to AI34, AI21 to AI24 and AI11 to AI14 for composite video CVBS or S-video Y/C signal pairs or component video input signals RGB plus separate sync (or Y-P_B-P_R plus separate sync).

Component signals with e.g. sync-on-Y or sync-on-green are also supported; they are fed to two ADC channels, one for the video contents, the other for sync conversion. Additionally, there are four differential reference inputs, which must be connected to ground via a capacitor equivalent to the decoupling capacitors at the 16 inputs. There are no peripheral components required other than these decoupling capacitors and 18 Ω /56 Ω termination resistors, one set per connected input signal; see application example in [Figure 90](#). Four anti-alias filters are integrated.

Clamp and gain control for the four ADCs are also integrated. An analog video output (pin AOUT) is provided for testing purposes.

Table 25: Analog pin description

Symbol	Pin ^[1]	I/O	Description	Bit
AI11 to AI14	J2, K1, K2 and L3 (27, 29, 31 and 34)	I	analog video signal inputs, e.g. 16 CVBS signals or eight Y/C pairs, or four RGB plus separate sync (or Y-P _B -P _R plus separate sync) signal groups can be connected simultaneously to this device; many combinations are possible; see Figure 48 to Figure 88	MODE5 to MODE0
AI21 to AI24	G4, G3, H2 and J3 (19, 21, 23 and 26)			
AI31 to AI34	E3, F2, F3 and G1 (11, 13, 15 and 18)			
AI41 to AI44	B1, D2, D1 and E1 (2, 5, 7 and 10)			
AOUT	M1 (36)	O	analog video output, for test purposes	AOSL2 to AOSL0
AI1D, AI2D, AI3D and AI4D	K3, H1, F1 and D3 (30, 22, 14 and 6)	I	analog reference pins for differential ADC operation; connect to ground via 47 nF	-

[1] Pin numbers for QFP160 in parenthesis.

9.2 Audio clock signals

The SAF7118 also synchronizes the audio clock and sampling rate to the video frame rate, via a very slow PLL. This ensures that the multimedia capture and compression processes always gather the same predefined number of samples per video frame.

An audio master clock AMCLK and two divided clocks ASCLK and ALRCLK are generated:

- ASCLK: can be used as audio serial clock
- ALRCLK: audio left/right channel clock

The ratios are programmable; see [Section 8.7](#).

Table 26: Audio clock pin description

Symbol	Pin [1]	I/O	Description	Bit
AMCLK	P11 (72)	O	audio master clock output	ACPF[17:0] 32h[1:0] 31h[7:0] 30h[7:0] and ACNI[21:0] 36h[5:0] 35h[7:0] 34h[7:0]
AMXCLK	M12 (76)	I	external audio master clock input for the clock division circuit, can be directly connected to output AMCLK for standard applications	
ASCLK	N11 (74)	O	serial audio clock output, can be synchronized to rising or falling edge of AMXCLK	SDIV[5:0] 38h[5:0] and SCPH[3Ah[0]]
ALRCLK	P12 (75)	O	audio channel (left/right) clock output, can be synchronized to rising or falling edge of ASCLK	LRDIV[5:0] 39h[5:0] and LRPH[3Ah[1]]

[1] Pin numbers for QFP160 in parenthesis.

9.3 Clock and real-time synchronization signals

For the generation of the line-locked video (pixel) clock LLC, and of the frame-locked audio serial bit clock, a crystal accurate frequency reference is required. An oscillator is built-in for fundamental or third harmonic crystals. The supported crystal frequencies are 32.11 MHz or 24.576 MHz (defined during reset by strapping pin ALRCLK).

Alternatively pin XTALI can be driven from an external single-ended oscillator.

The crystal oscillation can be propagated as a clock to other ICs in the system via pin XTOUT.

The Line-Locked Clock (LLC) is the double pixel clock of nominal 27 MHz. It is locked to the selected video input, generating baseband video pixels according to *ITU recommendation 601*. In order to support interfacing circuits, a direct pixel clock (LLC2) is also provided.

The pins for line and field timing reference signals are RTCO, RTS1 and RTS0. Various real-time status information can be selected for the RTS pins. The signals are always available (output) and reflect the synchronization operation of the decoder part in the SAF7118. The function of the RTS1 and RTS0 pins can be defined by bits RTSE1[3:0] 12h[7:4] and RTSE0[3:0] 12h[3:0].

Table 27: Clock and real-time synchronization signals

Symbol	Pin ^[1]	I/O	Description	Bit
Crystal oscillator				
XTALI	B4 (155)	I	input for crystal oscillator or reference clock	-
XTALO	A3 (156)	O	output of crystal oscillator	-
XTOUT	A2 (158)	O	reference (crystal) clock output drive (optional)	XTOUTE[14h[3]]
Real-time signals (RT port)				
LLC	P4 (46)	O	line-locked clock, nominal 27 MHz, double pixel clock locked to the selected video input signal	-
LLC2	N5 (48)	O	line-locked pixel clock, nominal 13.5 MHz	-
RTCO	L10 (71)	O	real-time control output, transfers real-time status information supporting RTC level 3.1 (see document "RTC Functional Description", available on request)	-
RTS0	M10 (69)	O	real-time status information line 0, can be programmed to carry various real-time information; see Table 56	RTSE0[3:0] 12h[3:0]
RTS1	N10 (70)	O	real-time status information line 1, can be programmed to carry various real-time information; see Table 57	RTSE1[3:0] 12h[7:4]

[1] Pin numbers for QFP160 in parenthesis.

9.4 Interrupt handling

9.4.1 Interrupt flags

The pin INT_A is an open-drain output (active LOW). All flags can be independently enabled. For the default setting all flags are disabled after reset. For the description of interrupt mask registers; see [Section 10.4](#).

9.4.1.1 Power state

PRDON: a power fail has been detected during normal operation, the device needs re-programming.

9.4.1.2 Video decoder

INTL: interlaced/non-interlaced source detected.

HLCK: horizontal PLL state changed (locked ↔ unlocked).

HLVLN: vertical lock state changed (locked ↔ unlocked).

FIDT: detected field frequency has changed (50 Hz ↔ 60 Hz).

RDCAP: ready for capture (true ↔ false).

DCSTD[1:0]: detected color standard has changed or color lost.

COPRO, COLSTR and TYPE3: various levels of copy protection have changed.

9.4.1.3 VBI data slicer

VPSV: VPS identification found or lost.

PPV: PALplus identification found or lost.

CCV: Closed caption identification found or lost.

9.4.1.4 Scaler

ERROF: scaler output formatting error detected.

9.4.2 Status reading conditions

The status information read after an interrupt will always be the LATEST state, that means the status will not be 'frozen' when an interrupt is being generated. Therefore, if there is a long time between interrupt generation and status reading, the original trigger condition might have been overridden by the present state.

9.4.3 Erasing conditions

The status flags are grouped into four 8-bit registers.

The interrupt flag will only be cleared on a read access to the status register in which the signal is located which caused the interrupt. This implies that it is sufficient to clear the interrupt by reading only those registers which have been enabled by their corresponding masks.

Priority: If a new trigger condition occurs at the SAME time (clock) on which a status is being read, the flag will NOT be cleared.

9.5 Video expansion port (X port)

The expansion port is intended for transporting video streams image data from other digital video circuits such as MPEG encoder/decoder and video phone codec, to the image port (I port).

The expansion port consists of two groups of signals/pins:

- 8-bit data, I/O, regularly components video Y-C_B-C_R 4 : 2 : 2, i.e. C_B-Y-C_R-Y, byte serial, exceptionally raw video samples (e.g. ADC test); in input mode the data bus can be extended to 16-bit by pins HPD7 to HPD0
- Clock, synchronization and auxiliary signals, accompanying the data stream, I/O

As output, these are direct copies of the decoder signals.

The data transfers through the expansion port represent a single D1 port, with half duplex mode. The SAV and EAV codes may be inserted optionally for data input (controlled by bit XCODE[92h[3]]). The input/output direction is switched for complete fields only.

Table 28: Signals dedicated to the expansion port

Symbol	Pin [1]	I/O	Description	Bit
XPD7 to XPD0	C11, A11, B10, A10, B9, A9, B8 and A8 (127, 128, 130, 131, 134, 135, 138 and 139)	I/O	X port data: in output mode controlled by decoder section, data format see Table 29 ; in input mode Y-C _B -C _R 4 : 2 : 2 serial input data or luminance part of a 16-bit Y-C _B -C _R 4 : 2 : 2 input	OFTS[2:0] 13h[2:0], 91h[7:0] and C1h[7:0]
XCLK	A7 (143)	I/O	clock at expansion port: if output, then copy of LLC; as input normally a double pixel clock of up to 32 MHz or a gated clock (clock gated with a qualifier)	XCKS[92h[0]]
XDQ	B7 (144)	I/O	data valid flag of the expansion port input (qualifier): if output, then decoder (HREF and VGATE) gate; see Figure 32	-
XRDY	A6 (146)	O	data request flag = ready to receive, to work with optional buffer in external device, to prevent internal buffer overflow; second function: input related task flag A/B	XRQT[83h[2]]
XRH	C7 (141)	I/O	horizontal reference signal for the X port: as output: HREF or HS from the decoder (see Figure 32); as input: a reference edge for horizontal input timing and a polarity for input field ID detection can be defined	XRHS[13h[6]], XFDH[92h[6]] and XDH[92h[2]]
XRV	D8 (140)	I/O	vertical reference signal for the X port: as output: V123 or field ID from the decoder (see Figure 30 and Figure 31); as input: a reference edge for vertical input timing and for input field ID detection can be defined	XRVS[1:0] 13h[5:4], XFDV[92h[7]] and XDV[1:0] 92h[5:4]
XTRI	B11 (126)	I	port control: switches X port input 3-state	XPE[1:0] 83h[1:0]

[1] Pin numbers for QFP160 in parenthesis.

9.5.1 X port configured as output

If data output is enabled at the expansion port, then the data stream from the decoder is presented. The data format of the 8-bit data bus is dependent on the chosen data type, selectable by the line control registers LCR2 to LCR24; see [Table 7](#). In contrast to the image port, the sliced data format is not available on the expansion port. Instead, raw CVBS samples are always transferred if any sliced data type is selected.

Some details of data types on the expansion port are as follows:

- **Active video** (data type 15): contains component Y-C_B-C_R 4 : 2 : 2 signal, 720 active pixels per line. The amplitude and offsets are programmable via DBR17 to DBR10, DCON7 to DCON0, DSAT7 to DSAT0, OFFU1, OFFU0, OFFV1 and OFFV0. The nominal levels are illustrated in [Figure 19](#).
- **Test line** (data type 6): is similar to the active video format, with some constraints within the data processing:
 - Adaptive chrominance comb filter, vertical filter (chrominance comb filter for NTSC standards, PAL phase error correction) within the chrominance processing are disabled

- Adaptive luminance comb filter, peaking and chrominance trap are bypassed within the luminance processing

This data type is defined for future enhancements. It could be activated for lines containing standard test signals within the vertical blanking period. Currently the most sources do not contain test lines. The nominal levels are illustrated in [Figure 19](#).

- **Raw samples** (data types 0 to 5 and 7 to 14): C_B-C_R samples are similar to data type 6, but CVBS samples are transferred instead of processed luminance samples within the Y time slots.

The amplitude and offset of the CVBS signal is programmable via RAWG7 to RAWG0 and RAWO7 to RAWO0; see [Section 10](#), [Table 63](#) and [Table 64](#). The nominal levels are illustrated in [Figure 20](#).

The relationship of LCR programming to line numbers is described in [Section 8.3](#), [Figure 28](#) and [Figure 29](#).

The data type selections by LCR are overruled by setting OFTS2 = 1 (subaddress 13h bit D2). This setting is mainly intended for device production test. The VPO-bus carries the upper or lower 8 bits of the two ADCs depending on the OFTS[1:0] 13h[1:0] settings; see [Table 58](#). The input configuration is done via MODE[5:0] 02h[5:0] settings; see [Table 40](#). If a Y/C mode is selected, the expansion port carries the multiplexed output signals of both ADCs, and in CVBS mode the output of only one ADC. No timing reference codes are generated in this mode.

Remark: The LSBs (bit D0) of the ADCs are also available on pin RTS0; see [Table 56](#).

The SAV/EAV timing reference codes define the start and end of valid data regions. The ITU-blanking code sequence ‘- 80 - 10 - 80 - 10 -...’ is transmitted during the horizontal blanking period between EAV and SAV.

The position of the F-bit is constant in accordance with ITU 656; see [Table 31](#) and [Table 32](#).

The V-bit can be generated in two different ways (see [Table 31](#) and [Table 32](#)) controlled via OFTS1 and OFTS0; see [Table 58](#).

The F and V bits change synchronously with the EAV code.

Table 29: Data format on the expansion port

Blanking period	Timing reference code (Hex) [1]	720 pixels Y-C _B -C _R 4 : 2 : 2 data [2]	Timing reference code (Hex) [1]	Blanking period
... 80 10	FF 00 00 SAV	C _B 0 Y0 C _R 0 Y1 C _B 2 Y2 ... C _R 718 Y719	FF 00 00 EAV	80 10 ...

[1] The generation of the timing reference codes can be suppressed by setting OFTS[2:0] to 010; see [Table 58](#). In this event the code sequence is replaced by the standard ‘- 80 - 10 -’ blanking values.
 [2] If raw samples or sliced data are selected by the line control registers (LCR2 to LCR24), the Y samples are replaced by CVBS samples.

Table 30: SAV/EAV format on expansion port XPD7 to XPD0

Bit	Symbol	Description
7		logic 1
6	F	field bit 1st field: F = 0 2nd field: F = 1 for vertical timing see Table 31 and Table 32
5	V	vertical blanking bit VBI: V = 1 active video: V = 0 for vertical timing see Table 31 and Table 32
4	H	format H = 0 in SAV format H = 1 in EAV format
3 to 0	P[3:0]	reserved; evaluation not recommended (protection bits according to ITU-R BT 656)

Table 31: 525 lines/60 Hz vertical timing

Line number	F (ITU 656)	V	
		OFTS[2:0] = 000 (ITU 656)	OFTS[2:0] = 001
1 to 3	1	1	according to selected VGATE position type via VSTA and VSTO (subaddresses 15h to 17h); see Table 60 to Table 62
4 to 19	0	1	
20	0	0	
21	0	0	
22 to 261	0	0	
262	0	0	
263	0	0	
264 and 265	0	1	
266 to 282	1	1	
283	1	0	
284	1	0	
285 to 524	1	0	
525	1	0	

Table 32: 625 lines/50 Hz vertical timing

Line number	F (ITU 656)	V	
		OFTS[2:0] = 000 (ITU 656)	OFTS[1:0] = 10
1 to 22	0	1	according to selected VGATE position type via VSTA and VSTO (subaddresses 15h to 17h); see Table 60 to Table 62
23	0	0	
24 to 309	0	0	
310	0	0	
311 and 312	0	1	
313 to 335	1	1	
336	1	0	
337 to 622	1	0	
623	1	0	
624 and 625	1	1	

9.5.2 X port configured as input

If the data input mode is selected at the expansion port, then the scaler can select its input data stream from the on-chip video decoder, or from the expansion port (controlled by bit SCSRC[1:0] 91h[5:4]). Byte serial Y-C_B-C_R 4 : 2 : 2, or subsets for other sampling schemes, or raw samples from an external ADC may be input (see also bits FSC[2:0] 91h[2:0]). The input stream must be accompanied by an external clock (XCLK), qualifier XDQ and reference signals XRH and XRV. Instead of the reference signal, embedded SAV and EAV codes according to ITU 656 are also accepted. The protection bits are not evaluated.

XRH and XRV carry the horizontal and vertical synchronization signals for the digital video stream through the expansion port. The field ID of the input video stream is carried in the phase (edge) of XRV and state of XRH, or directly as FS (frame sync, odd/even signal) on the XRV pin (controlled by XFDV[92h[7]], XFDH[92h[6]] and XDV[1:0] 92h[5:4]).

The trigger events on XRH (rising/falling edge) and XRV (rising/falling/both edges) for the scalers acquisition window are defined by XDV[1:0] 92h[5:4] and XDH[92h[2]]. The signal polarity of the qualifier can also be defined (bit XDQ[92h[1]]). Alternatively to a qualifier, the input clock can be applied to a gated clock (clock gated with a data qualifier, controlled by bit XCKS[92h[0]]). In this event, all input data will be qualified.

As the VBI data slicer may have different requirements for its input reference signals from X port XRV, XRH, XDQ, XCLK and XPD7 to XPD0, a second set of parameters is available for defining the meaning of the X port input signals and polarities for the VBI data slicer input path. These bits are defined in subaddresses 81h and 82h.

9.6 Image port (I port)

The image port transfers data from the scaler as well as from the VBI data slicer, if selected (maximum 33 MHz). The reference clock is available at the ICLK pin, as an output, or as an input (maximum 33 MHz). As output, ICLK is derived from the line-locked decoder or expansion port input clock. The data stream from the scaler output is normally discontinuous. Therefore valid data during a clock cycle is accompanied by a data qualifying (data valid) flag on pin IDQ. For pin constrained applications the IDQ pin can be programmed to function as a gated clock output (bit ICKS2[80h[2]]).

The data formats at the image port are defined in Dwords of 32 bits (4 bytes), such as the related FIFO structures. However the physical data stream at the image port is only 16-bit or 8-bit wide; in 16-bit mode data pins HPD7 to HPD0 are used for chrominance data. The four bytes of the Dwords are serialized in words or bytes.

Available formats are as follows:

- Y-C_B-C_R 4 : 2 : 2
- Y-C_B-C_R 4 : 1 : 1
- Raw samples
- Decoded VBI data

For handshake with the receiving VGA controller, or other memory or bus interface circuitry, F, H and V reference signals and programmable FIFO flags are provided. The information is provided on pins IGP0, IGP1, IGPH and IGPV. The functionality on these pins is controlled via subaddresses 84h and 85h.

VBI data is collected over an entire line in its own FIFO, and transferred as an uninterrupted block of bytes. Decoded VBI data can be signed by the VBI flag on pin IGP0 or IGP1.

As scaled video data and decoded VBI data may come from different and asynchronous sources, an arbitration scheme is needed. Normally the VBI data slicer has priority.

The image port consists of the pins and/or signals, as listed in [Table 33](#).

For pin constrained applications, or interfaces, the relevant timing and data reference signals can also get encoded into the data stream. Therefore the corresponding pins do not need to be connected. The minimum image port configuration requires 9 pins only, i.e. 8 pins for data including codes, and 1 pin for clock or gated clock. The inserted codes are defined in close relationship to the ITU-R BT.656 (D1) recommendation, where possible.

The following deviations from “ITU 656 recommendation” are implemented at the SAF7118 image port interface:

- SAV and EAV codes are only present in those lines, where data is to be transferred, i.e. active video lines, or VBI raw samples, no codes for empty lines
- There may be more or less than 720 pixels between SAV and EAV
- Data content and the number of clock cycles during horizontal and vertical blanking is undefined, and may not be constant
- Data stream may be interleaved with not-valid data codes, 00h, but SAV and EAV 4-byte codes are not interleaved with not-valid data codes
- There may be an irregular pattern of not-valid data, or IDQ, and as a result, C_B-Y-C_R-Y is not in a fixed phase to a regular clock divider
- VBI raw sample streams are enveloped with SAV and EAV, like normal video
- Decoded VBI data is transported as Ancillary (ANC) data, two modes:
 - Direct decoded VBI data bytes (8-bit) are directly placed in the ANC data field, 00h and FFh codes may appear in data block (violation to ITU-R BT.656)

- Recoded VBI data bytes (8-bit) directly placed in ANC data field, 00h and FFh codes will be recoded to even parity codes 03h and FCh to suppress invalid ITU-R BT.656 codes

There are no empty cycles in the ancillary code and its data field. The data codes 00h and FFh are suppressed (changed to 01h or FEh respectively) in the active video stream, as well as in the VBI raw sample stream (VBI pass-through). Optionally, the number range can be further limited.

Table 33: Signals dedicated to the image port

Symbol	Pin ^[1]	I/O	Description	Bit
IPD7 to IPD0	K11, J13, J14, H13, H14, H11, G12 and G14 (92 to 94, 97 to 100 and 102)	I/O	I port data	ICODE[93h[7]], ISWP[1:0] 85h[7:6] and IPE[1:0] 87h[1:0]
ICLK	M14 (84)	I/O	continuous reference clock at image port, can be input or output, as output decoder LLC or XCLK from X port	ICKS[1:0] 80h[1:0] and IPE[1:0] 87h[1:0]
IDQ	L13 (85)	O	data valid flag at image port, qualifier, with programmable polarity; secondary function: gated clock	ICKS2[80h[2]], IDQP[85h[0]] and IPE[1:0] 87h[1:0]
IGPH	K12 (91)	O	horizontal reference output signal, copy of the H gate signal of the scaler, with programmable polarity; alternative function: HRESET pulse	IDH[1:0] 84h[1:0], IRHP[85h[1]] and IPE[1:0] 87h[1:0]
IGPV	K14 (90)	O	vertical reference output signal, copy of the V gate signal of the scaler, with programmable polarity; alternative function: VRESET pulse	IDV[1:0] 84h[3:2], IRVP[85h[2]] and IPE[1:0] 87h[1:0]
IGP1	K13 (89)	O	general purpose output signal for I port	IDG12[86h[4]], IDG1[1:0] 84h[5:4], IG1P[85h[3]] and IPE[1:0] 87h[1:0]
IGP0	L14 (87)	O	general purpose output signal for I port	IDG02[86h[5]], IDG0[1:0] 84h[7:6], IG0P[85h[4]] and IPE[1:0] 87h[1:0]
ITRDY	N12 (77)	I	target ready input signals	-
ITRI	L12 (86)	I	port control, switches I port into 3-state	IPE[1:0] 87h[1:0]

[1] Pin numbers for QFP160 in parenthesis.

9.7 Host port for 16-bit extension of video data I/O (H port)

The H port pins HPD can be used for extension of the data I/O paths to 16-bit.

The I port has functional priority. If I8_16[93h[6]] is set to logic 1 the output drivers of the H port are enabled depending on the I port enable control. For I8_16 = 0, the HPD output is disabled.

Table 34: Signals dedicated to the host port

Symbol	Pin [1]	I/O	Description	Bit
HPD7 to HPD0	G13, F14, F13, E14, E12, E13, E11 and D14 (103, 105, 107 and 109 to 113)	I/O	16-bit extension for digital I/O (chrominance component)	IPE[1:0] 87h[1:0], ITRI[8Fh[6]] and I8_16[93h[6]]

[1] Pin numbers for QFP160 in parenthesis.

9.8 Basic input and output timing diagrams I port and X port

9.8.1 I port output timing

The following diagrams illustrate the output timing via the I port. IGPH and IGPV are logic 1 active gate signals. If reference pulses are programmed, these pulses are generated on the rising edge of the logic 1 active gates. Valid data is accompanied by the output data qualifier on pin IDQ. In addition invalid cycles are marked with output code 00h.

The IDQ output pin may be defined to be a gated clock output signal (ICLK AND internal IDQ).

9.8.2 X port input timing

At the X port the input timing requirements are the same as those for the I port output. But different to those below:

- It is not necessary to mark invalid cycles with a 00h code
- No constraints on the input qualifier (can be a random pattern)
- XCLK may be a gated clock (XCLK AND external XDQ)

Remark: All timings illustrated in [Figure 40](#) to [Figure 46](#) are given for an uninterrupted output stream (no handshake with the external hardware).

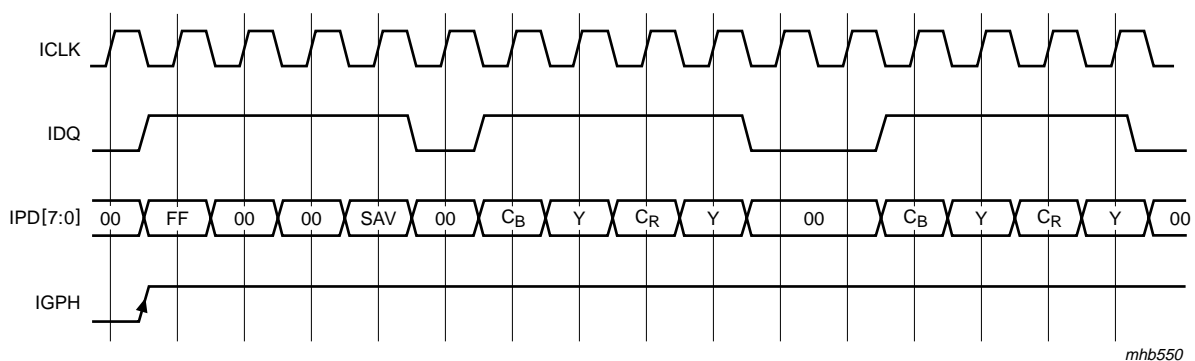

Fig 40. Output timing I port for serial 8-bit data at start of a line (ICODE = 1)

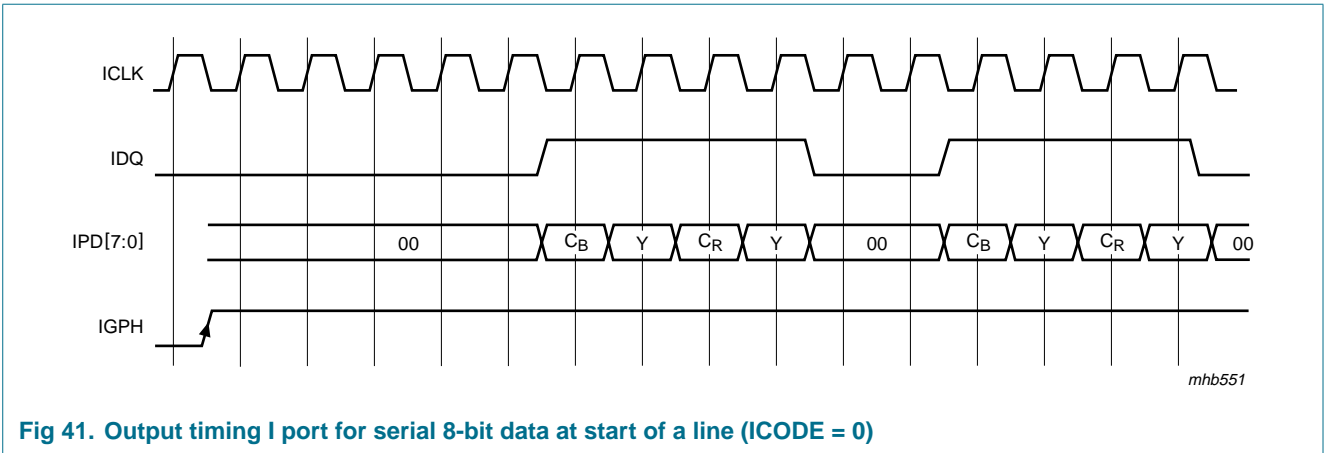

Fig 41. Output timing I port for serial 8-bit data at start of a line (ICODE = 0)

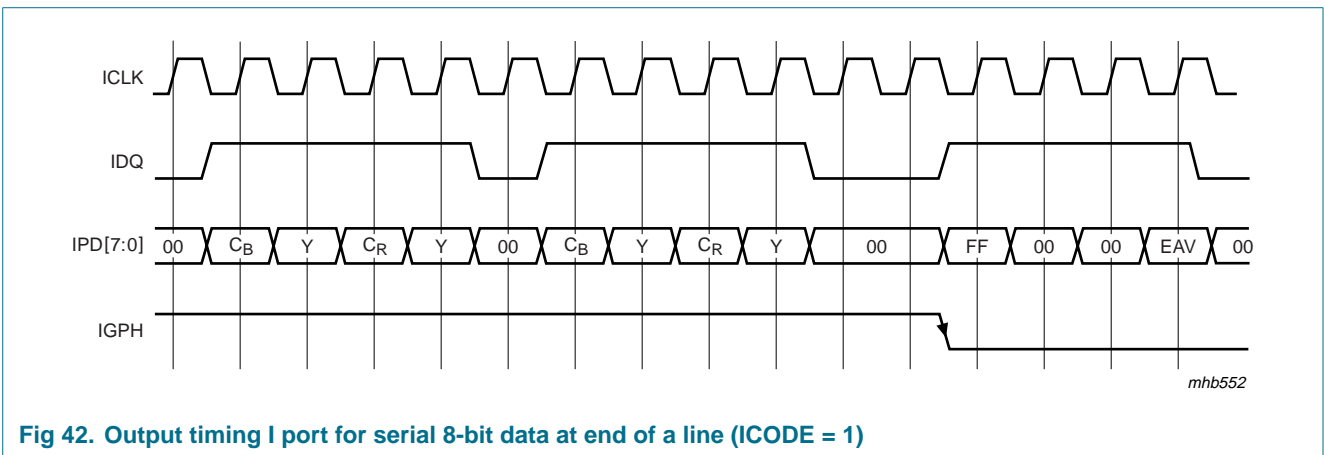

Fig 42. Output timing I port for serial 8-bit data at end of a line (ICODE = 1)

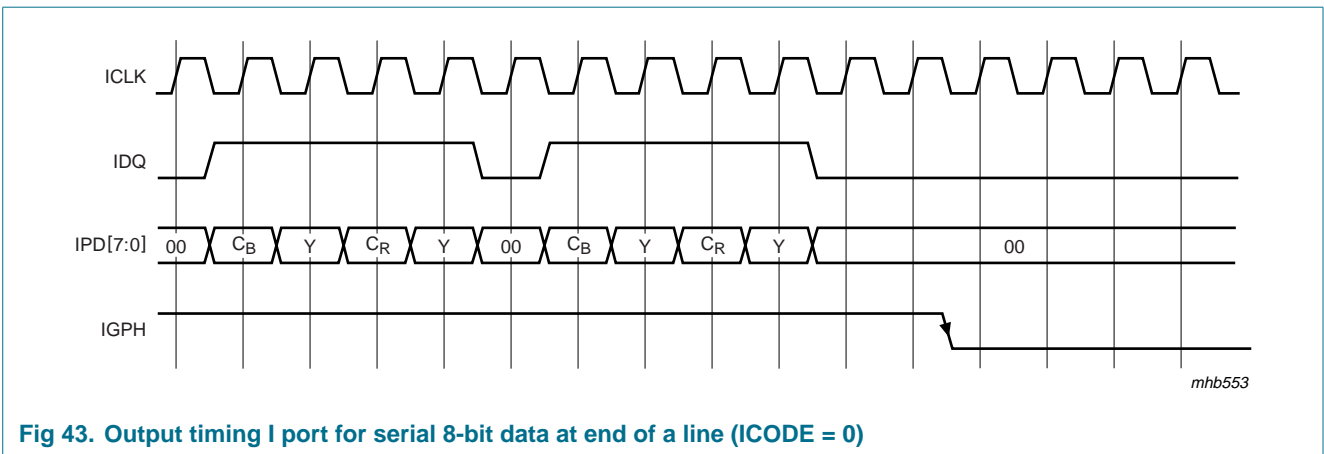
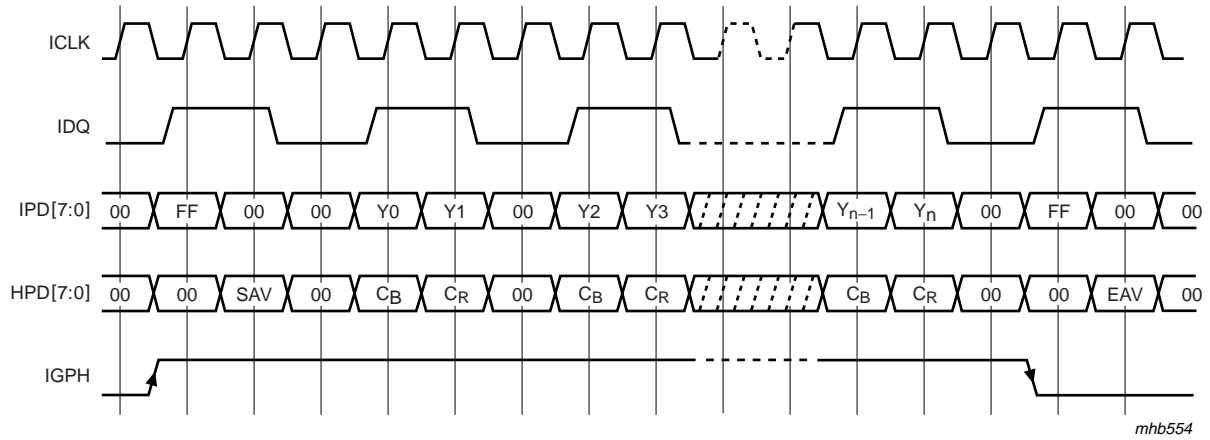
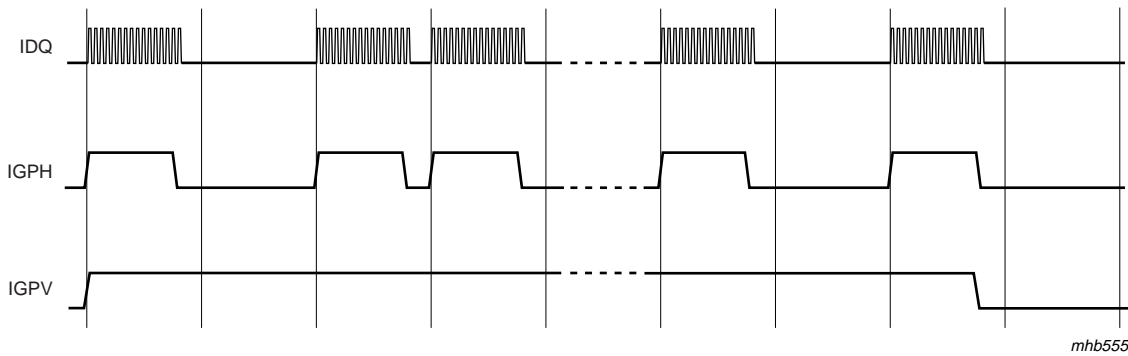

Fig 43. Output timing I port for serial 8-bit data at end of a line (ICODE = 0)



mhb554

Fig 44. Output timing for 16-bit data output via I port and H port with codes (ICODE = 1), timing is like 8-bit output, but packages of 2 bytes per valid cycle



mhb555

Fig 45. H gate and V gate output timing

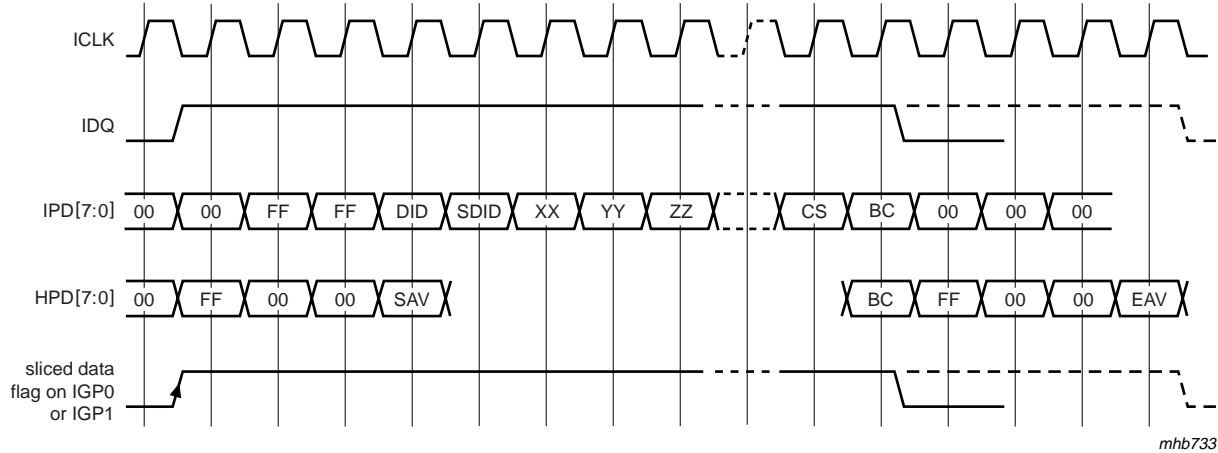

mhb733

Fig 46. Output timing for sliced VBI data in 8-bit serial output mode (dotted graphs for SAV/EAV mode)

10. I²C-bus description

The SAF7118 supports the 'fast mode' I²C-bus specification extension (data rate up to 400 kbit/s).

10.1 I²C-bus format

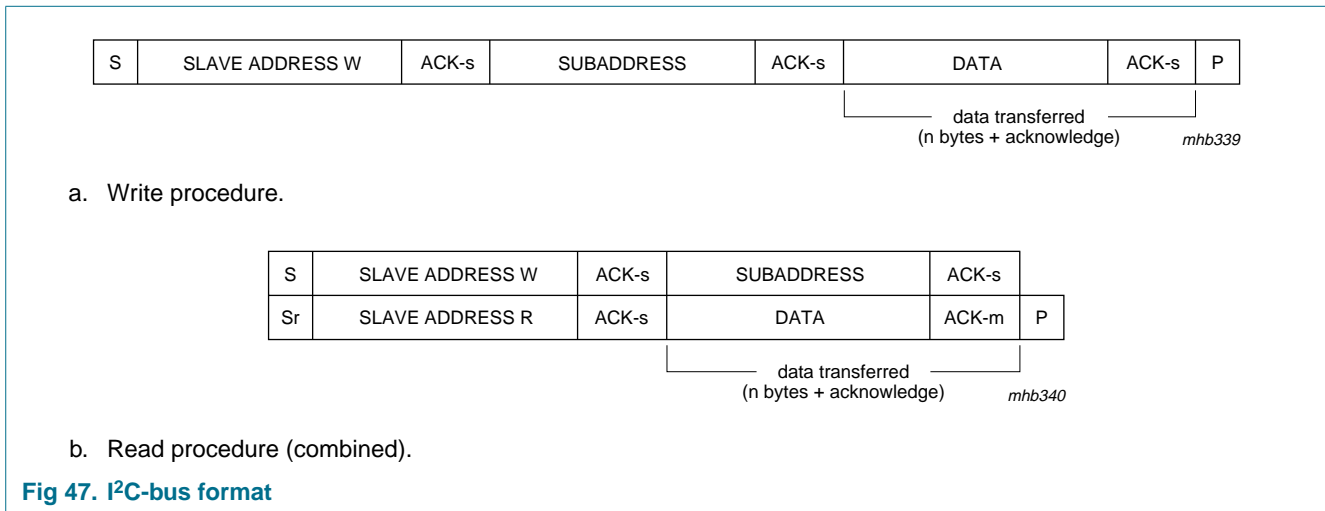

Fig 47. I²C-bus format

Table 35: Description of I²C-bus format

Code	Description
S	START condition
Sr	repeated START condition
SLAVE ADDRESS W	0100 0010 (42h, default) or 0100 0000 (40h) [1]
SLAVE ADDRESS R	0100 0011 (43h, default) or 0100 0001 (41h) [1]
ACK-s	acknowledge generated by the slave
ACK-m	acknowledge generated by the master
SUBADDRESS	subaddress byte; see Table 36 and Table 37
DATA	data byte; see Table 37 ; if more than one byte DATA is transmitted the subaddress pointer is automatically incremented
P	STOP condition

[1] If pin RTCO strapped to supply voltage via a 3.3 kΩ resistor.

Table 36: Subaddress description and access

Subaddress	Description	Access (read/write)
00h	chip version	read only
F0h to FFh	reserved	-
Video decoder: 01h to 1Fh		
01h to 05h	front-end part	read and write
06h to 19h	decoder part	read and write
1Ah to 1Dh	reserved	-
1Eh and 1Fh	video decoder status bytes	read only
Component processing and interrupt masking: 20h to 2Fh		
20h to 22h	reserved	-
23h to 25h	analog input control	read and write
26h to 28h	reserved	-
29h to 2Ch	component control	read and write
2Dh to 2Fh	interrupt mask	read and write
Audio clock generation: 30h to 3Fh		
30h to 3Ah	audio clock generator	read and write
3Bh to 3Fh	reserved	-
General purpose VBI data slicer: 40h to 7Fh		
40h to 5Eh	VBI data slicer	read and write
5Fh	reserved	-
60h to 62h	VBI data slicer status	read only
63h to 7Fh	reserved	-
X port, I port and the scaler: 80h to EFh		
80h to 8Fh	task independent global settings	read and write
90h to BFh	task A definition	read and write
C0h to EFh	task B definition	read and write

Table 37: I²C-bus receiver/transmitter overview

Register function	Subaddress	D7	D6	D5	D4	D3	D2	D1	D0
Chip version: register 00h									
Chip version (read only)	00h	ID7	ID6	ID5	ID4	-	-	-	-
Video decoder: registers 01h to 1Fh									
Front-end part: registers 01h to 05h									
Increment delay	01h	[1]	WPOFF	GUDL1	GUDL0	IDEL3	IDEL2	IDEL1	IDEL0
Analog input control 1	02h	FUSE1	FUSE0	MODE5	MODE4	MODE3	MODE2	MODE1	MODE0
Analog input control 2	03h	[1]	HLNRS	VBSL	CPOFF	HOLDG	GAFIX	GAI28	GAI18
Analog input control 3	04h	GAI17	GAI16	GAI15	GAI14	GAI13	GAI12	GAI11	GAI10
Analog input control 4	05h	GAI27	GAI26	GAI25	GAI24	GAI23	GAI22	GAI21	GAI20
Decoder part: registers 06h to 1Fh									
Horizontal sync start	06h	HSB7	HSB6	HSB5	HSB4	HSB3	HSB2	HSB1	HSB0
Horizontal sync stop	07h	HSS7	HSS6	HSS5	HSS4	HSS3	HSS2	HSS1	HSS0
Sync control	08h	AUFD	FSEL	FOET	HTC1	HTC0	HPLL	VNOI1	VNOI0
Luminance control	09h	BYPS	YCOMB	LDEL	LUBW	LUF13	LUF12	LUF11	LUF10
Luminance brightness control	0Ah	DBRI7	DBRI6	DBRI5	DBRI4	DBRI3	DBRI2	DBRI1	DBRI0
Luminance contrast control	0Bh	DCON7	DCON6	DCON5	DCON4	DCON3	DCON2	DCON1	DCON0
Chrominance saturation control	0Ch	DSAT7	DSAT6	DSAT5	DSAT4	DSAT3	DSAT2	DSAT1	DSAT0
Chrominance hue control	0Dh	HUEC7	HUEC6	HUEC5	HUEC4	HUEC3	HUEC2	HUEC1	HUEC0
Chrominance control 1	0Eh	CDTO	CSTD2	CSTD1	CSTD0	DCVF	FCTC	AUTO0	CCOMB
Chrominance gain control	0Fh	ACGC	CGAIN6	CGAIN5	CGAIN4	CGAIN3	CGAIN2	CGAIN1	CGAIN0
Chrominance control 2	10h	OFFU1	OFFU0	OFFV1	OFFV0	CHBW	LCBW2	LCBW1	LCBW0
Mode/delay control	11h	COLO	RTP1	HDEL1	HDEL0	RTP0	YDEL2	YDEL1	YDEL0
RT signal control	12h	RTSE13	RTSE12	RTSE11	RTSE10	RTSE03	RTSE02	RTSE01	RTSE00
RT/X port output control	13h	RTCE	XRHS	XRVS1	XRVS0	HLSEL	OFTS2	OFTS1	OFTS0
Analog/ADC/compatibility control	14h	CM99	UPTCV	AOSL1	AOSL0	XTOUTE	AUTO1	APCK1	APCK0
VGATE start, FID change	15h	VSTA7	VSTA6	VSTA5	VSTA4	VSTA3	VSTA2	VSTA1	VSTA0
VGATE stop	16h	VSTO7	VSTO6	VSTO5	VSTO4	VSTO3	VSTO2	VSTO1	VSTO0
Miscellaneous, VGATE configuration and MSBs	17h	LLCE	LLC2E	LATY2	LATY1	LATY0	VGPS	VSTO8	VSTA8
Raw data gain control	18h	RAWG7	RAWG6	RAWG5	RAWG4	RAWG3	RAWG2	RAWG1	RAWG0
Raw data offset control	19h	RAWO7	RAWO6	RAWO5	RAWO4	RAWO3	RAWO2	RAWO1	RAWO0

Table 37: I²C-bus receiver/transmitter overview...continued

Register function	Subaddress	D7	D6	D5	D4	D3	D2	D1	D0
Reserved	1Ah to 1Dh	[1]	[1]	[1]	[1]	[1]	[1]	[1]	[1]
Status byte 1 video decoder (read only)	1Eh	-	HLCK	SLTCA	GLIMT	GLIMB	WIPA	DCSTD1	DCSTD0
Status byte 2 video decoder (read only)	1Fh	INTL	HLVLN	FIDT	-	TYPE3	COLSTR	COPRO	RDCAP
Component processing and interrupt masking part: registers 20h to 2Fh									
Reserved	20h to 22h	[1]	[1]	[1]	[1]	[1]	[1]	[1]	[1]
Analog input control 5	23h	AOSL2	ADPE	EXCLK	REFA	[1]	EXMCE	GAI48	GAI38
Analog input control 6	24h	GAI37	GAI36	GAI35	GAI34	GAI33	GAI32	GAI31	GAI30
Analog input control 7	25h	GAI47	GAI46	GAI45	GAI44	GAI43	GAI42	GAI41	GAI40
Reserved	26h to 28h	[1]	[1]	[1]	[1]	[1]	[1]	[1]	[1]
Component delay	29h	FSWE	FSWI	FSWDL1	FSWDL0	CMFI	CPDL2	CPDL1	CPDL0
Component brightness control	2Ah	CBRI7	CBRI6	CBRI5	CBRI4	CBRI3	CBRI2	CBRI1	CBRI0
Component contrast control	2Bh	CCON7	CCON6	CCON5	CCON4	CCON3	CCON2	CCON1	CCON0
Component saturation control	2Ch	CSAT7	CSAT6	CSAT5	CSAT4	CSAT3	CSAT2	CSAT1	CSAT0
Interrupt mask 1	2Dh	[1]	[1]	[1]	MVPSV	MPPV	MCCV	[1]	MERROF
Interrupt mask 2	2Eh	[1]	MHLCK	[1]	[1]	[1]	[1]	MDCSTD1	MDCSTD0
Interrupt mask 3	2Fh	MINTL	MHLVLN	MFIDT	[1]	MTYPE3	MCOLSTR	MCOPRO	MRDCAP
Audio clock generator part: registers 30h to 3Fh									
Audio master clock cycles per field	30h	ACPF7	ACPF6	ACPF5	ACPF4	ACPF3	ACPF2	ACPF1	ACPF0
	31h	ACPF15	ACPF14	ACPF13	ACPF12	ACPF11	ACPF10	ACPF9	ACPF8
	32h	[1]	[1]	[1]	[1]	[1]	[1]	ACPF17	ACPF16
Reserved	33h	[1]	[1]	[1]	[1]	[1]	[1]	[1]	[1]
Audio master clock nominal increment	34h	ACNI7	ACNI6	ACNI5	ACNI4	ACNI3	ACNI2	ACNI1	ACNI0
	35h	ACNI15	ACNI14	ACNI13	ACNI12	ACNI11	ACNI10	ACNI9	ACNI8
	36h	[1]	[1]	ACNI21	ACNI20	ACNI19	ACNI18	ACNI17	ACNI16
Reserved	37h	[1]	[1]	[1]	[1]	[1]	[1]	[1]	[1]
Clock ratio AMXCLK to ASCLK	38h	[1]	[1]	SDIV5	SDIV4	SDIV3	SDIV2	SDIV1	SDIV0
Clock ratio ASCLK to ALRCLK	39h	[1]	[1]	LRDIV5	LRDIV4	LRDIV3	LRDIV2	LRDIV1	LRDIV0
Audio clock generator basic setup	3Ah	[1]	[1]	[1]	[1]	APLL	AMVR	LRPH	SCPH
Reserved	3Bh to 3Fh	[1]	[1]	[1]	[1]	[1]	[1]	[1]	[1]

Table 37: I²C-bus receiver/transmitter overview...continued

Register function	Subaddress	D7	D6	D5	D4	D3	D2	D1	D0
General purpose VBI data slicer part: registers 40h to 7Fh									
Slicer control 1	40h	[1]	HAM_N	FCE	HUNT_N	[1]	[1]	[1]	[1]
LCR2 to LCR24 (n = 2 to 24)	41h to 57h	LCRn_7	LCRn_6	LCRn_5	LCRn_4	LCRn_3	LCRn_2	LCRn_1	LCRn_0
Programmable framing code	58h	FC7	FC6	FC5	FC4	FC3	FC2	FC1	FC0
Horizontal offset for slicer	59h	HOFF7	HOFF6	HOFF5	HOFF4	HOFF3	HOFF2	HOFF1	HOFF0
Vertical offset for slicer	5Ah	VOFF7	VOFF6	VOFF5	VOFF4	VOFF3	VOFF2	VOFF1	VOFF0
Field offset and MSBs for horizontal and vertical offset	5Bh	FOFF	RECODE	[1]	VOFF8	[1]	HOFF10	HOFF9	HOFF8
Reserved (for testing)	5Ch	[1]	[1]	[1]	[1]	[1]	[1]	[1]	[1]
Header and data identification (DID) code control	5Dh	FVREF	[1]	DID5	DID4	DID3	DID2	DID1	DID0
Sliced data identification (SDID) code	5Eh	[1]	[1]	SDID5	SDID4	SDID3	SDID2	SDID1	SDID0
Reserved	5Fh	[1]	[1]	[1]	[1]	[1]	[1]	[1]	[1]
Slicer status byte 0 (read only)	60h	-	FC8V	FC7V	VPSV	PPV	CCV	-	-
Slicer status byte 1 (read only)	61h	-	-	F21_N	LN8	LN7	LN6	LN5	LN4
Slicer status byte 2 (read only)	62h	LN3	LN2	LN1	LN0	DT3	DT2	DT1	DT0
Reserved	63h to 7Fh	[1]	[1]	[1]	[1]	[1]	[1]	[1]	[1]
X port, I port and the scaler part: registers 80h to EFh									
Task independent global settings: 80h to 8Fh									
Global control 1	80h	[1]	SMOD	TEB	TEA	ICKS3	ICKS2	ICKS1	ICKS0
Reserved	81h and 82h	[1]	[1]	[1]	[1]	[1]	[1]	[1]	[1]
X port I/O enable and output clock phase control	83h	[1]	[1]	XPCK1	XPCK0	[1]	XRQT	XPE1	XPE0
I port signal definitions	84h	IDG01	IDG00	IDG11	IDG10	IDV1	IDV0	IDH1	IDH0
I port signal polarities	85h	ISWP1	ISWP0	ILLV	IG0P	IG1P	IRVP	IRHP	IDQP
I port FIFO flag control and arbitration	86h	VITX1	VITX0	IDG02	IDG12	FFL1	FFL0	FEL1	FEL0
I port I/O enable, output clock and gated clock phase control	87h	IPCK3	IPCK2	IPCK1	IPCK0	[1]	[1]	IPE1	IPE0
Power save/ADC port control	88h	DOSL1	DOSL0	SWRST	DPROG	SLM3	[1]	SLM1	SLM0
Reserved	89h to 8Eh	[1]	[1]	[1]	[1]	[1]	[1]	[1]	[1]
Status information scaler part	8Fh	XTRI	ITRI	FFIL	FFOV	PRDON	ERROF	FIDSCI	FIDSCO

Table 37: I²C-bus receiver/transmitter overview...continued

Register function	Subaddress	D7	D6	D5	D4	D3	D2	D1	D0
Task A definition: registers 90h to BFh									
<i>Basic settings and acquisition window definition</i>									
Task handling control	90h	CONLH	OFIDC	FSKP2	FSKP1	FSKP0	RPTSK	STRC1	STRC0
X port formats and configuration	91h	CONLV	HLDFV	SCSRC1	SCSRC0	SCRQE	FSC2	FSC1	FSC0
X port input reference signal definition	92h	XFDV	XFDH	XDV1	XDV0	XCODE	XDH	XDQ	XCKS
I port output formats and configuration	93h	ICODE	I8_16	FYSK	FOI1	FOI0	FSI2	FSI1	FSI0
Horizontal input window start	94h	XO7	XO6	XO5	XO4	XO3	XO2	XO1	XO0
	95h	[1]	[1]	[1]	[1]	XO11	XO10	XO9	XO8
Horizontal input window length	96h	XS7	XS6	XS5	XS4	XS3	XS2	XS1	XS0
	97h	[1]	[1]	[1]	[1]	XS11	XS10	XS9	XS8
Vertical input window start	98h	YO7	YO6	YO5	YO4	YO3	YO2	YO1	YO0
	99h	[1]	[1]	[1]	[1]	YO11	YO10	YO9	YO8
Vertical input window length	9Ah	YS7	YS6	YS5	YS4	YS3	YS2	YS1	YS0
	9Bh	[1]	[1]	[1]	[1]	YS11	YS10	YS9	YS8
Horizontal output window length	9Ch	XD7	XD6	XD5	XD4	XD3	XD2	XD1	XD0
	9Dh	[1]	[1]	[1]	[1]	XD11	XD10	XD9	XD8
Vertical output window length	9Eh	YD7	YD6	YD5	YD4	YD3	YD2	YD1	YD0
	9Fh	[1]	[1]	[1]	[1]	YD11	YD10	YD9	YD8
<i>FIR filtering and prescaling</i>									
Horizontal prescaling	A0h	[1]	[1]	XPSC5	XPSC4	XPSC3	XPSC2	XPSC1	XPSC0
Accumulation length	A1h	[1]	[1]	XACL5	XACL4	XACL3	XACL2	XACL1	XACL0
Prescaler DC gain and FIR prefilter control	A2h	PFUV1	PFUV0	PFY1	PFY0	XC2_1	XDCG2	XDCG1	XDCG0
Reserved	A3h	[1]	[1]	[1]	[1]	[1]	[1]	[1]	[1]
Luminance brightness control	A4h	BRIG7	BRIG6	BRIG5	BRIG4	BRIG3	BRIG2	BRIG1	BRIG0
Luminance contrast control	A5h	CONT7	CONT6	CONT5	CONT4	CONT3	CONT2	CONT1	CONT0
Chrominance saturation control	A6h	SATN7	SATN6	SATN5	SATN4	SATN3	SATN2	SATN1	SATN0
Reserved	A7h	[1]	[1]	[1]	[1]	[1]	[1]	[1]	[1]

Table 37: I²C-bus receiver/transmitter overview...continued

Register function	Subaddress	D7	D6	D5	D4	D3	D2	D1	D0
<i>Horizontal phase scaling</i>									
Horizontal luminance scaling increment	A8h	XSCY7	XSCY6	XSCY5	XSCY4	XSCY3	XSCY2	XSCY1	XSCY0
	A9h	[1]	[1]	[1]	XSCY12	XSCY11	XSCY10	XSCY9	XSCY8
Horizontal luminance phase offset	AAh	XPHY7	XPHY6	XPHY5	XPHY4	XPHY3	XPHY2	XPHY1	XPHY0
Reserved	ABh	[1]	[1]	[1]	[1]	[1]	[1]	[1]	[1]
Horizontal chrominance scaling increment	ACh	XSCC7	XSCC6	XSCC5	XSCC4	XSCC3	XSCC2	XSCC1	XSCC0
	ADh	[1]	[1]	[1]	XSCC12	XSCC11	XSCC10	XSCC9	XSCC8
Horizontal chrominance phase offset	A Eh	XPHC7	XPHC6	XPHC5	XPHC4	XPHC3	XPHC2	XPHC1	XPHC0
Reserved	AFh	[1]	[1]	[1]	[1]	[1]	[1]	[1]	[1]
<i>Vertical scaling</i>									
Vertical luminance scaling increment	B0h	YSCY7	YSCY6	YSCY5	YSCY4	YSCY3	YSCY2	YSCY1	YSCY0
	B1h	YSCY15	YSCY14	YSCY13	YSCY12	YSCY11	YSCY10	YSCY9	YSCY8
Vertical chrominance scaling increment	B2h	YSCC7	YSCC6	YSCC5	YSCC4	YSCC3	YSCC2	YSCC1	YSCC0
	B3h	YSCC15	YSCC14	YSCC13	YSCC12	YSCC11	YSCC10	YSCC9	YSCC8
Vertical scaling mode control	B4h	[1]	[1]	[1]	YMIR	[1]	[1]	[1]	YMODE
Reserved	B5h to B7h	[1]	[1]	[1]	[1]	[1]	[1]	[1]	[1]
Vertical chrominance phase offset '00'	B8h	YPC07	YPC06	YPC05	YPC04	YPC03	YPC02	YPC01	YPC00
Vertical chrominance phase offset '01'	B9h	YPC17	YPC16	YPC15	YPC14	YPC13	YPC12	YPC11	YPC10
Vertical chrominance phase offset '10'	BAh	YPC27	YPC26	YPC25	YPC24	YPC23	YPC22	YPC21	YPC20
Vertical chrominance phase offset '11'	BBh	YPC37	YPC36	YPC35	YPC34	YPC33	YPC32	YPC31	YPC30
Vertical luminance phase offset '00'	BCh	YPY07	YPY06	YPY05	YPY04	YPY03	YPY02	YPY01	YPY00
Vertical luminance phase offset '01'	BDh	YPY17	YPY16	YPY15	YPY14	YPY13	YPY12	YPY11	YPY10
Vertical luminance phase offset '10'	BEh	YPY27	YPY26	YPY25	YPY24	YPY23	YPY22	YPY21	YPY20
Vertical luminance phase offset '11'	BFh	YPY37	YPY36	YPY35	YPY34	YPY33	YPY32	YPY31	YPY30
<i>Task B definition registers C0h to EFh</i>									
<i>Basic settings and acquisition window definition</i>									
Task handling control	C0h	CONLH	OFIDC	FSKP2	FSKP1	FSKP0	RPTSK	STRC1	STRC0
X port formats and configuration	C1h	CONLV	HLDFV	SCSRC1	SCSRC0	SCRQE	FSC2	FSC1	FSC0
Input reference signal definition	C2h	XFDV	XFDH	XDV1	XDV0	XCODE	XDH	XDQ	XCKS
I port formats and configuration	C3h	ICODE	I8_16	FYSK	FOI1	FOI0	FSI2	FSI1	FSI0

Table 37: I²C-bus receiver/transmitter overview...continued

Register function	Subaddress	D7	D6	D5	D4	D3	D2	D1	D0
Horizontal input window start	C4h	XO7	XO6	XO5	XO4	XO3	XO2	XO1	XO0
	C5h	[1]	[1]	[1]	[1]	XO11	XO10	XO9	XO8
Horizontal input window length	C6h	XS7	XS6	XS5	XS4	XS3	XS2	XS1	XS0
	C7h	[1]	[1]	[1]	[1]	XS11	XS10	XS9	XS8
Vertical input window start	C8h	YO7	YO6	YO5	YO4	YO3	YO2	YO1	YO0
	C9h	[1]	[1]	[1]	[1]	YO11	YO10	YO9	YO8
Vertical input window length	CAh	YS7	YS6	YS5	YS4	YS3	YS2	YS1	YS0
	CBh	[1]	[1]	[1]	[1]	YS11	YS10	YS9	YS8
Horizontal output window length	CCh	XD7	XD6	XD5	XD4	XD3	XD2	XD1	XD0
	CDh	[1]	[1]	[1]	[1]	XD11	XD10	XD9	XD8
Vertical output window length	CEh	YD7	YD6	YD5	YD4	YD3	YD2	YD1	YD0
	CFh	[1]	[1]	[1]	[1]	YD11	YD10	YD9	YD8
<i>FIR filtering and prescaling</i>									
Horizontal prescaling	D0h	[1]	[1]	XPSC5	XPSC4	XPSC3	XPSC2	XPSC1	XPSC0
Accumulation length	D1h	[1]	[1]	XACL5	XACL4	XACL3	XACL2	XACL1	XACL0
Prescaler DC gain and FIR prefilter control	D2h	PFUV1	PFUV0	PFY1	PFY0	XC2_1	XDCG2	XDCG1	XDCG0
Reserved	D3h	[1]	[1]	[1]	[1]	[1]	[1]	[1]	[1]
Luminance brightness control	D4h	BRIG7	BRIG6	BRIG5	BRIG4	BRIG3	BRIG2	BRIG1	BRIG0
Luminance contrast control	D5h	CONT7	CONT6	CONT5	CONT4	CONT3	CONT2	CONT1	CONT0
Chrominance saturation control	D6h	SATN7	SATN6	SATN5	SATN4	SATN3	SATN2	SATN1	SATN0
Reserved	D7h	[1]	[1]	[1]	[1]	[1]	[1]	[1]	[1]
<i>Horizontal phase scaling</i>									
Horizontal luminance scaling increment	D8h	XSCY7	XSCY6	XSCY5	XSCY4	XSCY3	XSCY2	XSCY1	XSCY0
	D9h	[1]	[1]	[1]	XSCY12	XSCY11	XSCY10	XSCY9	XSCY8
Horizontal luminance phase offset	DAh	XPHY7	XPHY6	XPHY5	XPHY4	XPHY3	XPHY2	XPHY1	XPHY0
Reserved	DBh	[1]	[1]	[1]	[1]	[1]	[1]	[1]	[1]
Horizontal chrominance scaling increment	DCh	XSCC7	XSCC6	XSCC5	XSCC4	XSCC3	XSCC2	XSCC1	XSCC0
	DDh	[1]	[1]	[1]	XSCC12	XSCC11	XSCC10	XSCC9	XSCC8
Horizontal chrominance phase offset	DEh	XPHC7	XPHC6	XPHC5	XPHC4	XPHC3	XPHC2	XPHC1	XPHC0
Reserved	DFh	[1]	[1]	[1]	[1]	[1]	[1]	[1]	[1]

Table 37: I²C-bus receiver/transmitter overview...continued

Register function	Subaddress	D7	D6	D5	D4	D3	D2	D1	D0
<i>Vertical scaling</i>									
Vertical luminance scaling increment	E0h	YSCY7	YSCY6	YSCY5	YSCY4	YSCY3	YSCY2	YSCY1	YSCY0
	E1h	YSCY15	YSCY14	YSCY13	YSCY12	YSCY11	YSCY10	YSCY9	YSCY8
Vertical chrominance scaling increment	E2h	YSCC7	YSCC6	YSCC5	YSCC4	YSCC3	YSCC2	YSCC1	YSCC0
	E3h	YSCC15	YSCC14	YSCC13	YSCC12	YSCC11	YSCC10	YSCC9	YSCC8
Vertical scaling mode control	E4h	[1]	[1]	[1]	YMIR	[1]	[1]	[1]	YMODE
Reserved	E5h to E7h	[1]	[1]	[1]	[1]	[1]	[1]	[1]	[1]
Vertical chrominance phase offset '00'	E8h	YPC07	YPC06	YPC05	YPC04	YPC03	YPC02	YPC01	YPC00
Vertical chrominance phase offset '01'	E9h	YPC17	YPC16	YPC15	YPC14	YPC13	YPC12	YPC11	YPC10
Vertical chrominance phase offset '10'	EAh	YPC27	YPC26	YPC25	YPC24	YPC23	YPC22	YPC21	YPC20
Vertical chrominance phase offset '11'	EBh	YPC37	YPC36	YPC35	YPC34	YPC33	YPC32	YPC31	YPC30
Vertical luminance phase offset '00'	ECh	YPY07	YPY06	YPY05	YPY04	YPY03	YPY02	YPY01	YPY00
Vertical luminance phase offset '01'	EDh	YPY17	YPY16	YPY15	YPY14	YPY13	YPY12	YPY11	YPY10
Vertical luminance phase offset '10'	EEh	YPY27	YPY26	YPY25	YPY24	YPY23	YPY22	YPY21	YPY20
Vertical luminance phase offset '11'	EFh	YPY37	YPY36	YPY35	YPY34	YPY33	YPY32	YPY31	YPY30

[1] All unused control bits must be programmed with logic 0 to ensure compatibility to future enhancements.

10.2 I²C-bus details

10.2.1 Subaddress 00h

Table 38: Chip Version (CV) identification; 00h[7:4]; read only register

Function	Logic levels			
	ID7	ID6	ID5	ID4
Chip Version (CV)	CV3	CV2	CV1	CV0

10.2.2 Subaddress 01h

The programming of the horizontal increment delay is used to match internal processing delays to the delay of the ADC. Use recommended position only.

Table 39: Horizontal increment delay; 01h[6:0]

Bit	Description	Symbol	Value	Function
D6	white peak control off	WPOFF [1]	0	white peak control active (AD signal is attenuated, if nominal luminance output white level is exceeded)
			1	white peak control disabled
D[5:4]	update hysteresis for 9-bit gain; see Figure 9	GUDL[1:0]	00	off
			01	±1 LSB
			10	±2 LSB
			11	±3 LSB
D[3:0]	increment delay	IDEL[3:0]	1111	no update
			1110	minimum delay
			0111	recommended position
			0000	maximum delay

[1] HLNRS = 1 should not be used in combination with WPOFF = 0.

10.2.3 Subaddress 02h

Table 40: Analog input control 1 (AICO1); 02h[7:0] ^[1]

Bit	Description	Symbol	Value	Function
D[7:6]	analog function select; see Figure 4 and Figure 6	FUSE[1:0]	00	amplifier plus anti-alias filter bypassed
			01	amplifier plus anti-alias filter bypassed
			10	amplifier active
			11	amplifier plus anti-alias filter active
CVBS modes 1				
D[5:0]	mode selection	MODE[5:0]	00 0000	Mode 00: CVBS (automatic gain) from AI11; see Figure 48
			00 0001	Mode 01: CVBS (automatic gain) from AI12; see Figure 49
			00 0010	Mode 02: CVBS (automatic gain) from AI21; see Figure 50
			00 0011	Mode 03: CVBS (automatic gain) from AI22; see Figure 51
			00 0100	Mode 04: CVBS (automatic gain) from AI23; see Figure 52
			00 0101	Mode 05: CVBS (automatic gain) from AI24; see Figure 53
Y + C modes 1				
D[5:0]	mode selection	MODE[5:0]	00 0110	Mode 06: Y (automatic gain) from AI11 + C (gain adjustable via GAI28 to GAI20) from AI21 ^[2] ; see Figure 54
			00 0111	Mode 07: Y (automatic gain) from AI12 + C (gain adjustable via GAI28 to GAI20) from AI22 ^[2] ; see Figure 55
			00 1000	Mode 08: Y (automatic gain) from AI11 + C (gain adapted to Y gain) from AI21 ^[2] ; see Figure 56
			00 1001	Mode 09: Y (automatic gain) from AI12 + C (gain adapted to Y gain) from AI22 ^[2] ; see Figure 57
			00 1010	Mode 0A: Y (automatic gain) from AI13 + C (gain adjustable via GAI28 to GAI20) from AI23 ^[2] ; see Figure 58
			00 1011	Mode 0B: Y (automatic gain) from AI14 + C (gain adjustable via GAI28 to GAI20) from AI24 ^[2] ; see Figure 59
			00 1100	Mode 0C: Y (automatic gain) from AI13 + C (gain adapted to Y gain) from AI23 ^[2] ; see Figure 60
			00 1101	Mode 0D: Y (automatic gain) from AI14 + C (gain adapted to Y gain) from AI24 ^[2] ; see Figure 61

Table 40: Analog input control 1 (AICO1); 02h[7:0] [\[1\]](#)...continued

Bit	Description	Symbol	Value	Function
CVBS modes 2				
D[5:0]	mode selection	MODE[5:0]	00 1110	Mode 0E: CVBS (automatic gain) from AI13; see Figure 62
			00 1111	Mode 0F: CVBS (automatic gain) from AI14; see Figure 63
			01 0000	Mode 10: CVBS (automatic gain) from AI31; see Figure 64
			01 0001	Mode 11: CVBS (automatic gain) from AI32; see Figure 65
			01 0010	Mode 12: CVBS (automatic gain) from AI41; see Figure 66
			01 0011	Mode 13: CVBS (automatic gain) from AI42; see Figure 67
			01 0100	Mode 14: CVBS (automatic gain) from AI43; see Figure 68
			01 0101	Mode 15: CVBS (automatic gain) from AI44; see Figure 69
Y + C modes 2				
D[5:0]	mode selection	MODE[5:0]	01 0110	Mode 16: Y (automatic gain) from AI31 + C (gain adjustable via GAI28 to GAI20) from AI41 [2] ; see Figure 70
			01 0111	Mode 17: Y (automatic gain) from AI32 + C (gain adjustable via GAI28 to GAI20) from AI42 [2] ; see Figure 71
			01 1000	Mode 18: Y (automatic gain) from AI31 + C (gain adapted to Y gain) from AI41 [2] ; see Figure 72
			01 1001	Mode 19: Y (automatic gain) from AI32 + C (gain adapted to Y gain) from AI42 [2] ; see Figure 73
			01 1010	Mode 1A: Y (automatic gain) from AI33 + C (gain adjustable via GAI28 to GAI20) from AI43 [2] ; see Figure 74
			01 1011	Mode 1B: Y (automatic gain) from AI34 + C (gain adjustable via GAI28 to GAI20) from AI44 [2] ; see Figure 75
			01 1100	Mode 1C: Y (automatic gain) from AI33 + C (gain adapted to Y gain) from AI43 [2] ; see Figure 76
			01 1101	Mode 1D: Y (automatic gain) from AI34 + C (gain adapted to Y gain) from AI44 [2] ; see Figure 77
CVBS modes 3				
D[5:0]	mode selection	MODE[5:0]	01 1110	Mode 1E: CVBS (automatic gain) from AI33; see Figure 78
			01 1111	Mode 1F: CVBS (automatic gain) from AI34; see Figure 79

Table 40: Analog input control 1 (AICO1); 02h[7:0] [\[1\]](#)...continued

Bit	Description	Symbol	Value	Function
Y-P_B-P_R modes				
D[5:0]	mode selection	MODE[5:0]	10 0000	Mode 20: SY-P _B -P _R (automatic gain for sync channel only) from AI11, AI21, AI31, AI41; see Figure 80
			10 0001	Mode 21: SY-P _B -P _R (automatic gain for sync channel only) from AI12, AI22, AI32, AI42; see Figure 81
			10 0010 to 10 1101	reserved
			10 1110	Mode 2E: SY-P _B -P _R (automatic gain for sync channel only) from AI13, AI23, AI33, AI43; see Figure 82
			10 1110	Mode 2F: SY-P _B -P _R (automatic gain for sync channel only) from AI14, AI24, AI34, AI44; see Figure 83
RGB modes				
D[5:0]	mode selection	MODE[5:0]	11 0000	Mode 30: SRGB (automatic gain for sync channel only) from AI11, AI21, AI31, AI41; see Figure 84
			11 0001	Mode 31: SRGB (automatic gain for sync channel only) from AI12, AI22, AI32, AI42; see Figure 85
			11 0010 to 11 1101	reserved
			11 1110	Mode 3E: SRGB (automatic gain for sync channel only) from AI13, AI23, AI33, AI43; see Figure 88
			11 1111	Mode 3F: SRGB (automatic gain for sync channel only) from AI14, AI24, AI34, AI44; see Figure 90

Table 40: Analog input control 1 (AICO1); 02h[7:0] [\[1\]](#)...continued

Bit	Description	Symbol	Value	Function
VSB modes; see Figure 88				
D[5:0]	mode selection	MODE[5:0]	00 0000	Mode 00: input AI11; REFA = 1, DOSL = 0, GAFIX = 1
			00 0001	Mode 01: input AI12; REFA = 1, DOSL = 0, GAFIX = 1
			00 1110	Mode 0E: input AI13; REFA = 1, DOSL = 0, GAFIX = 1
			00 1111	Mode 0F: input AI14; REFA = 1, DOSL = 0, GAFIX = 1
			00 0010	Mode 02: input AI21; REFA = 1, DOSL = 1, GAFIX = 1
			00 0011	Mode 03: input AI22; REFA = 1, DOSL = 1, GAFIX = 1
			00 0100	Mode 04: input AI23; REFA = 1, DOSL = 1, GAFIX = 1
			00 0101	Mode 05: input AI24; REFA = 1, DOSL = 1, GAFIX = 1
			01 0000	Mode 10: input AI31; REFA = 1, DOSL = 2, GAFIX = 1
			01 0001	Mode 11: input AI32; REFA = 1, DOSL = 2, GAFIX = 1
			01 1110	Mode 1E: input AI33; REFA = 1, DOSL = 2, GAFIX = 1
			01 1111	Mode 1F: input AI34; REFA = 1, DOSL = 2, GAFIX = 1
			01 0010	Mode 12: input AI41; REFA = 1, DOSL = 3, GAFIX = 1
			01 0011	Mode 13: input AI42; REFA = 1, DOSL = 3, GAFIX = 1
			01 0100	Mode 14: input AI43; REFA = 1, DOSL = 3, GAFIX = 1
01 0101	Mode 15: input AI44; REFA = 1, DOSL = 3, GAFIX = 1			

[1] Always refer to [Table 70](#), usage of bits FSWE and FSWI.

[2] To take full advantage of the Y/C modes 06 to 0D and 16 to 1D the I²C-bus bit BYPS (subaddress 09h, bit D7) should be set to logic 1 (full luminance bandwidth).

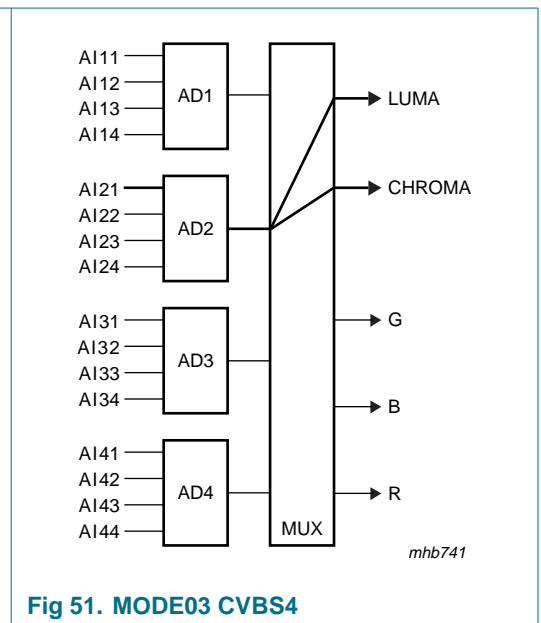
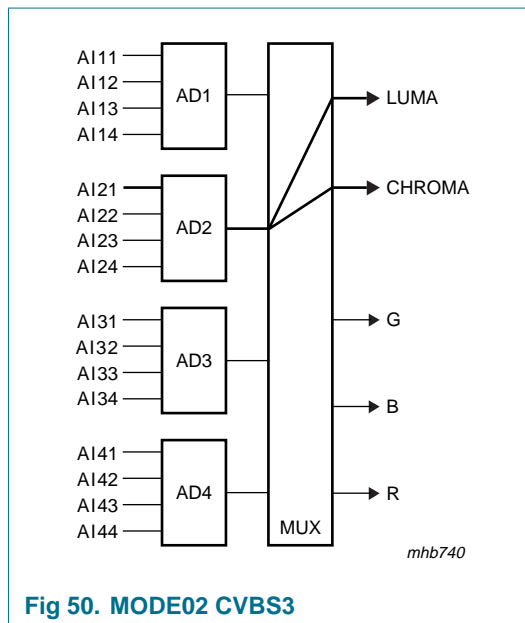
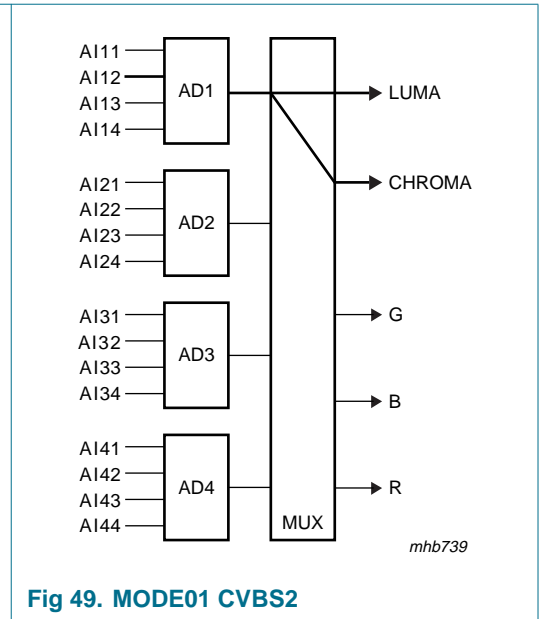
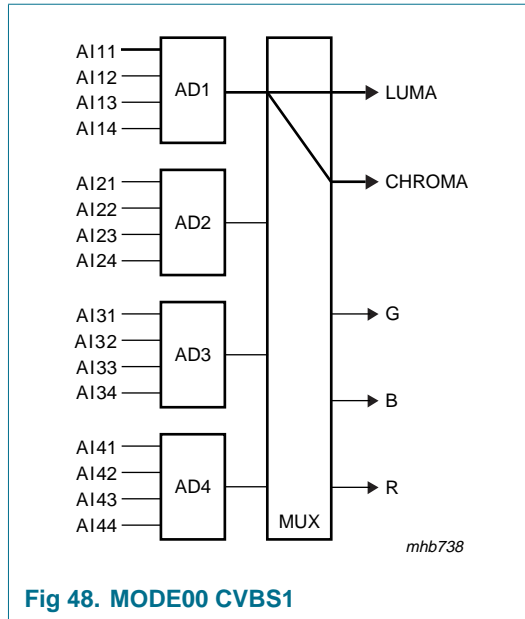

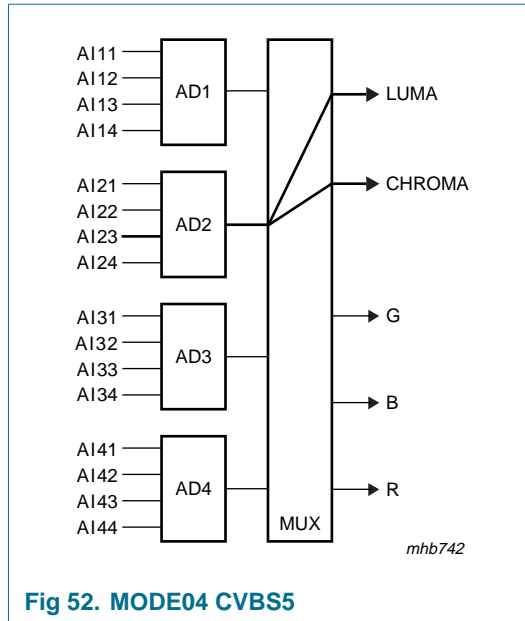

Fig 52. MODE04 CVBS5

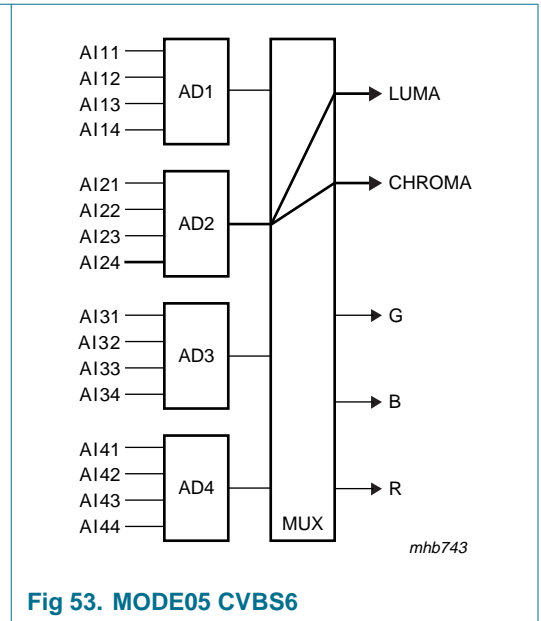

Fig 53. MODE05 CVBS6

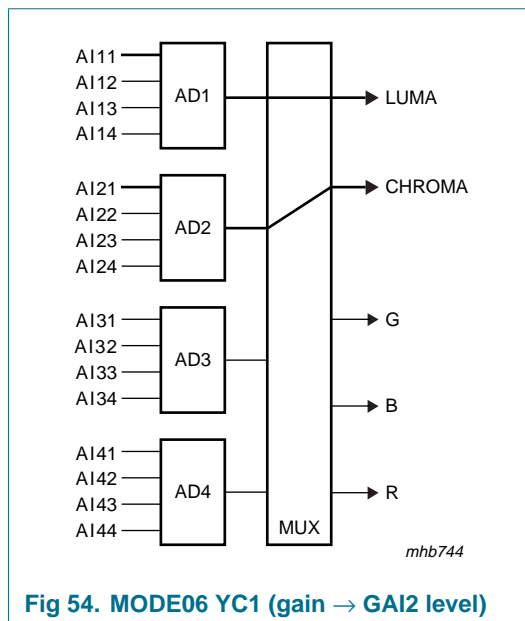

Fig 54. MODE06 YC1 (gain → GAI2 level)

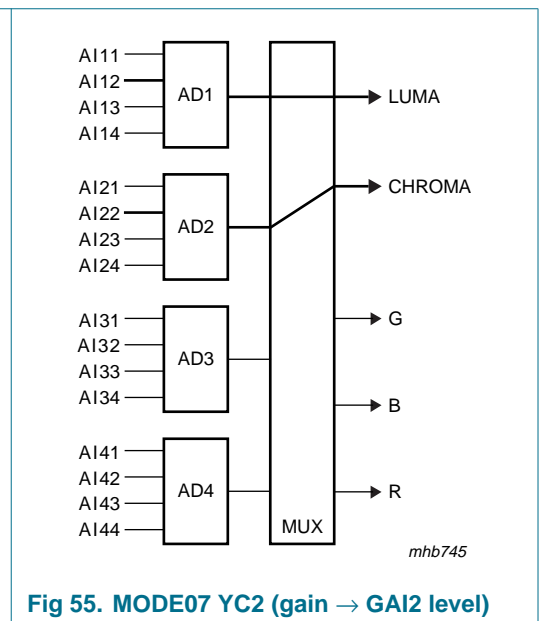
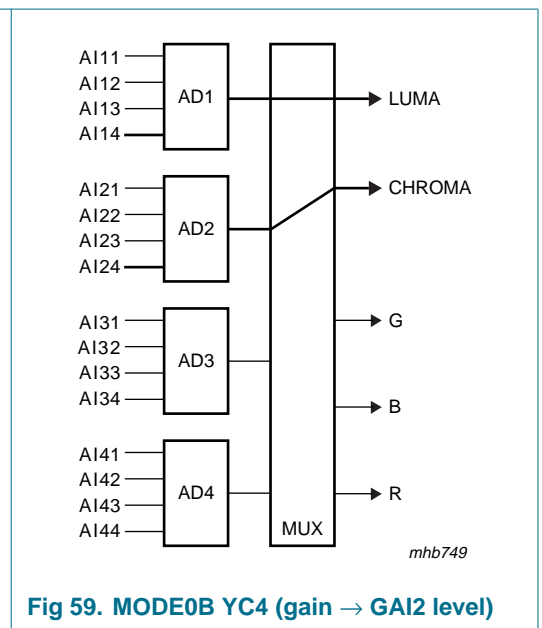
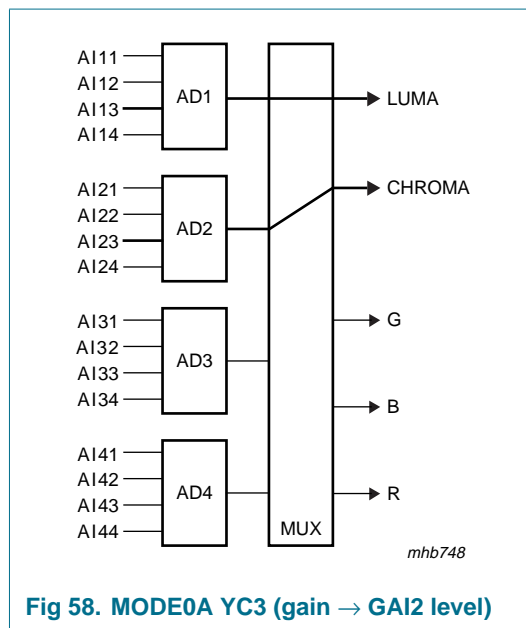
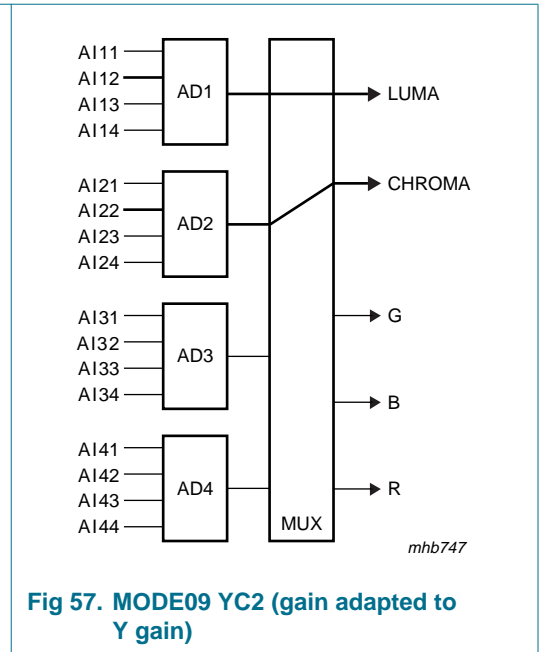
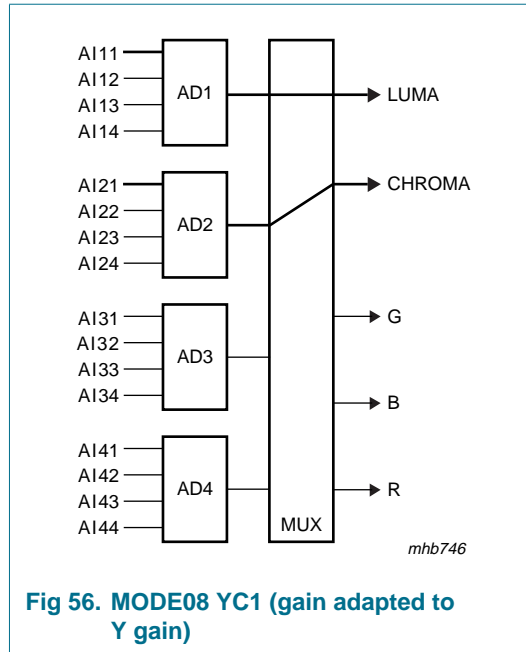
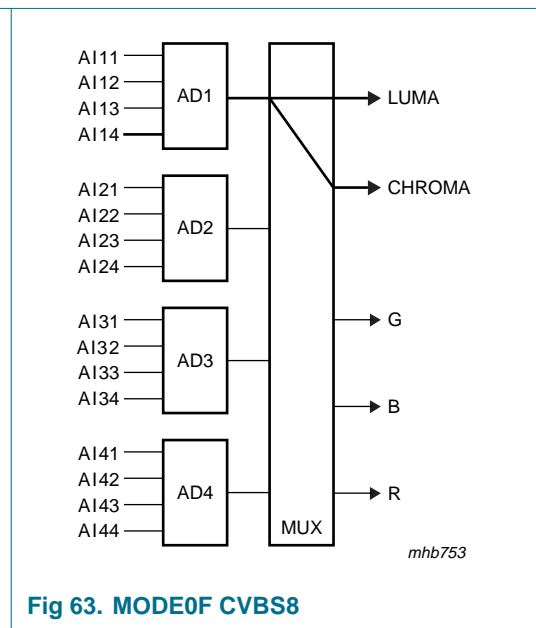
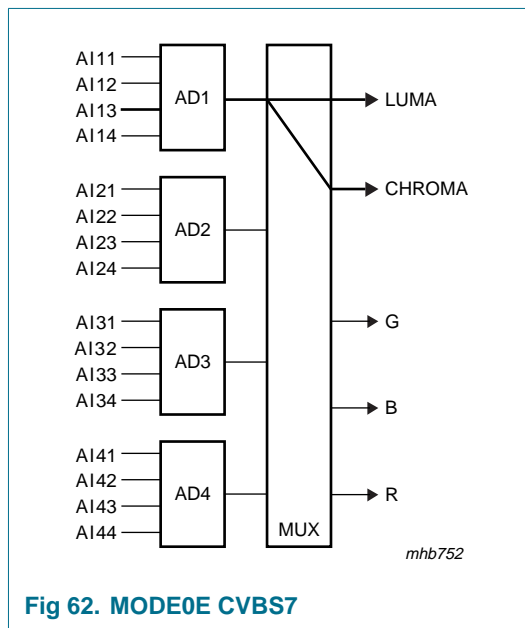
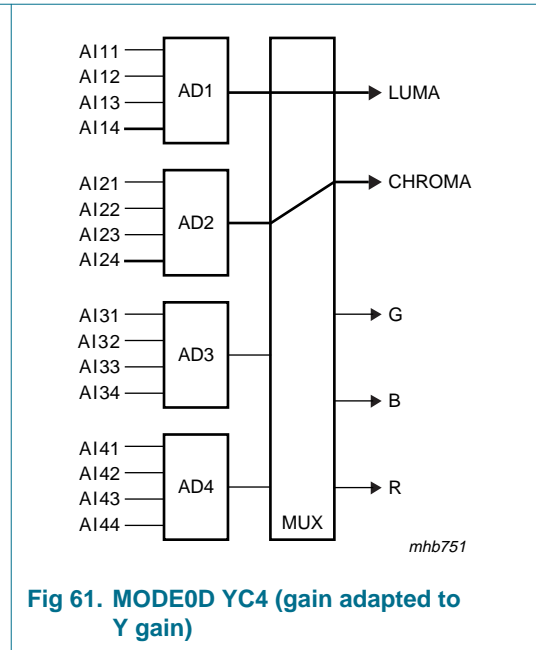
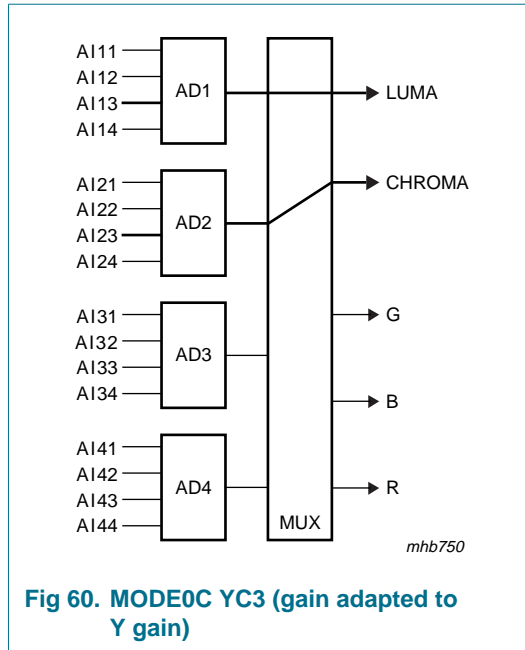
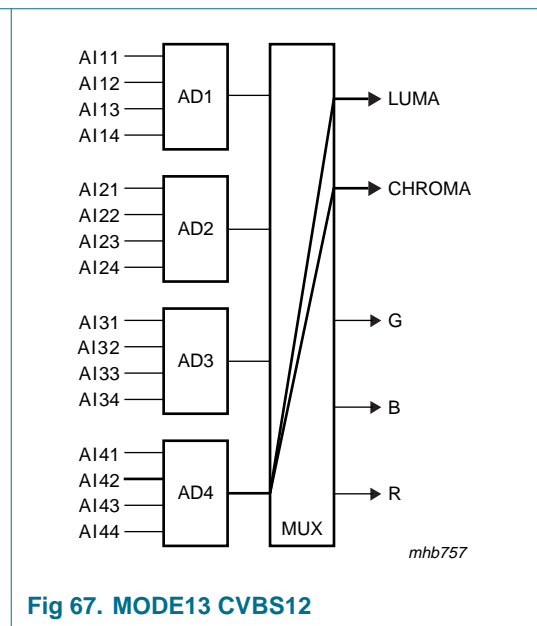
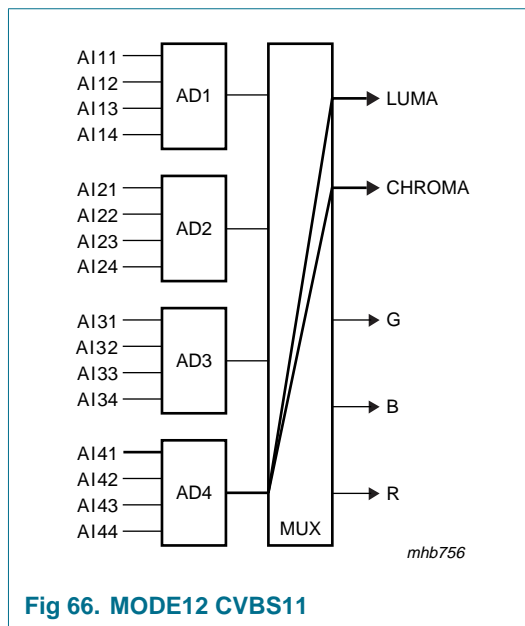
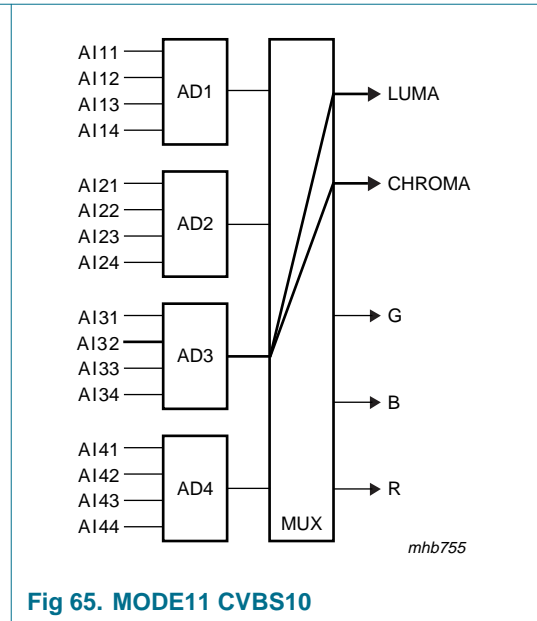
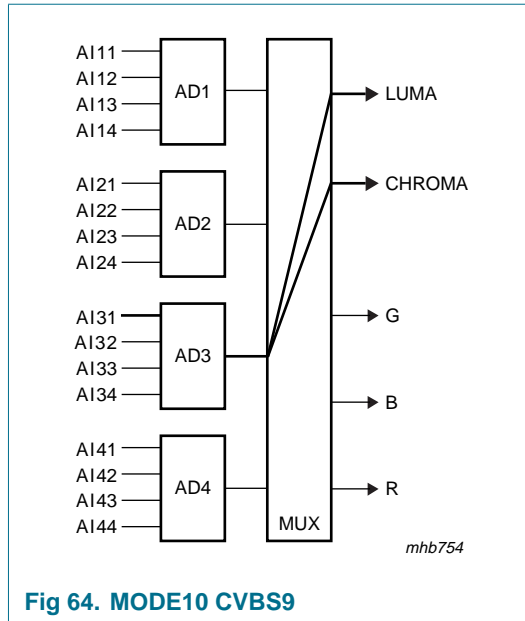

Fig 55. MODE07 YC2 (gain → GAI2 level)







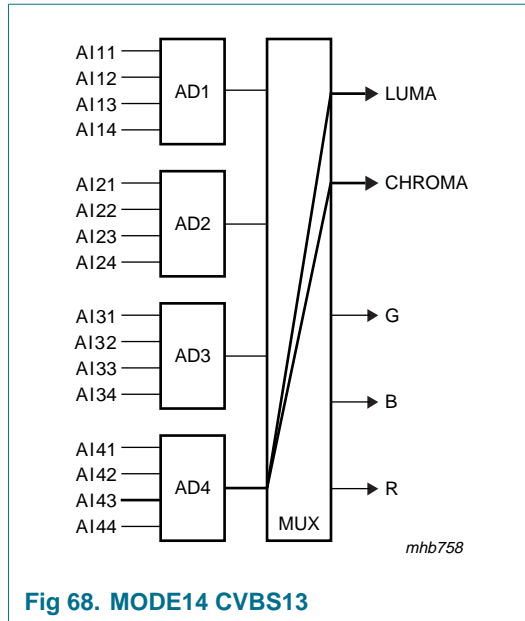

Fig 68. MODE14 CVBS13

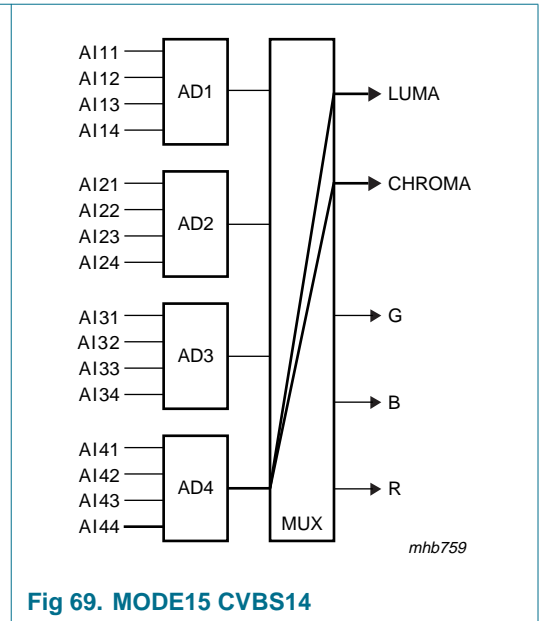

Fig 69. MODE15 CVBS14

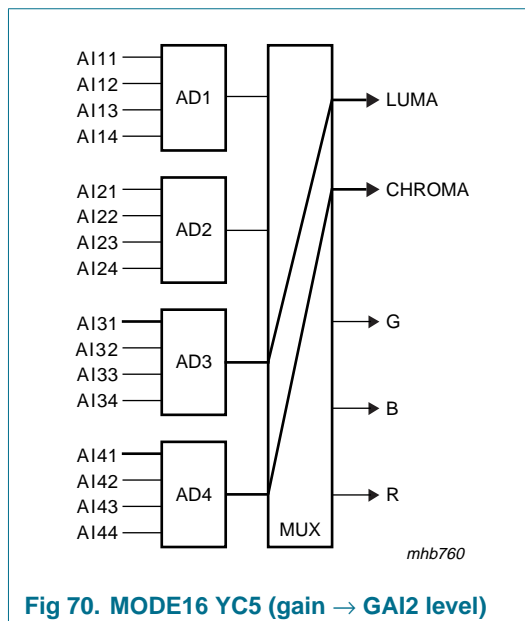

Fig 70. MODE16 YC5 (gain → GAI2 level)

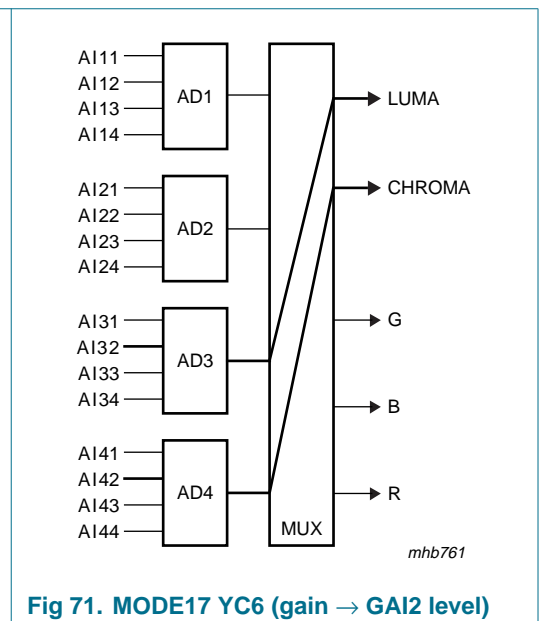
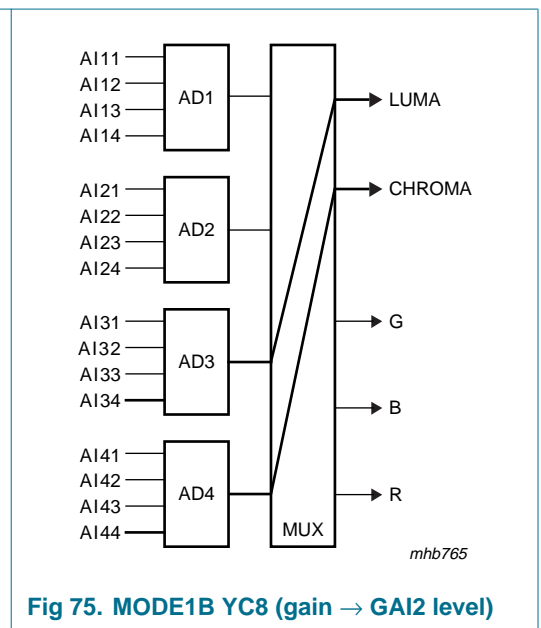
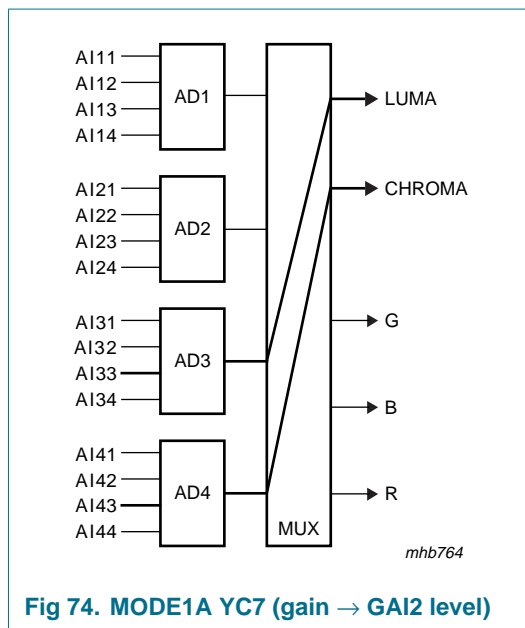
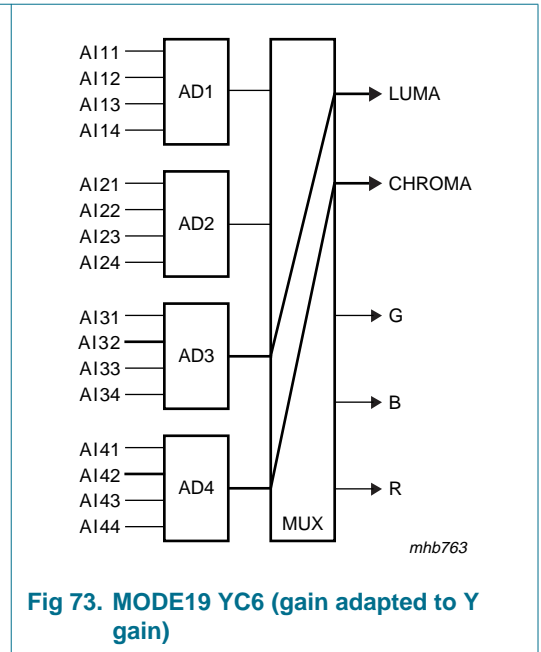
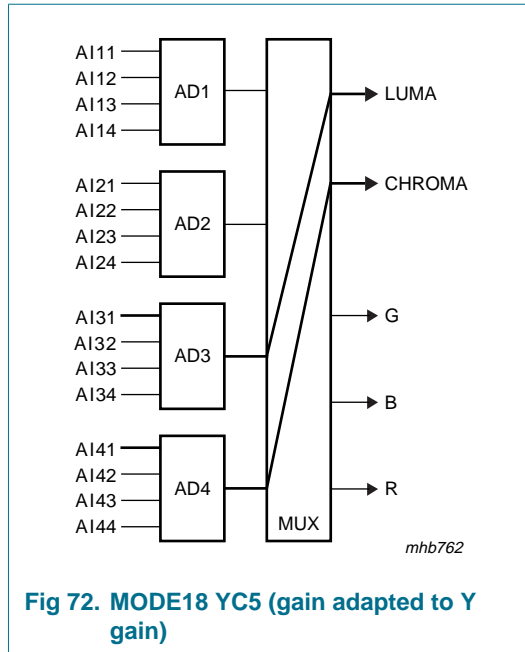
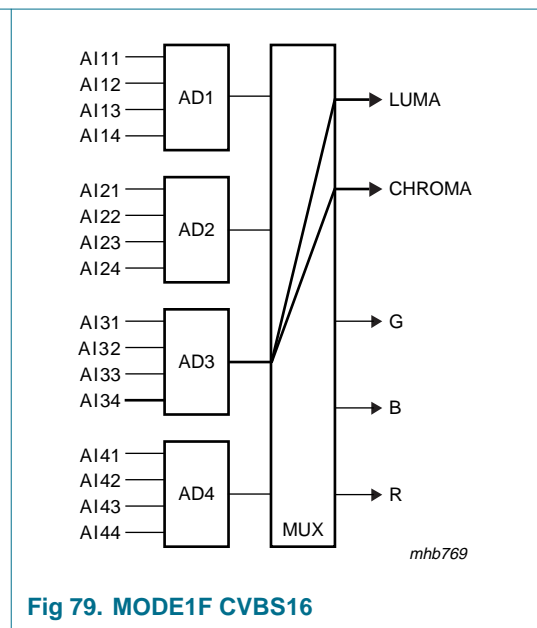
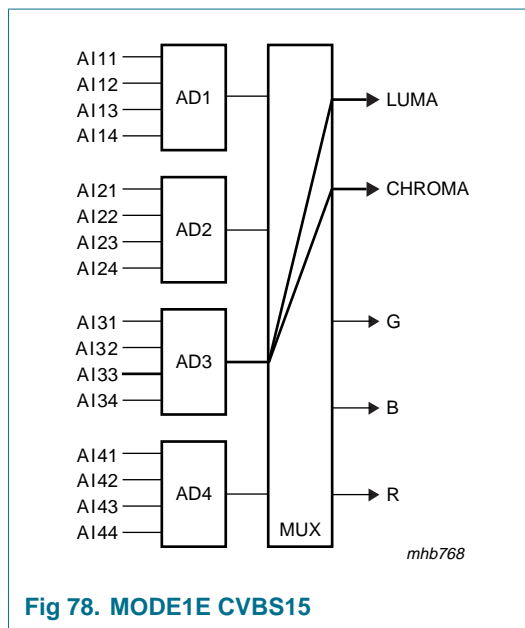
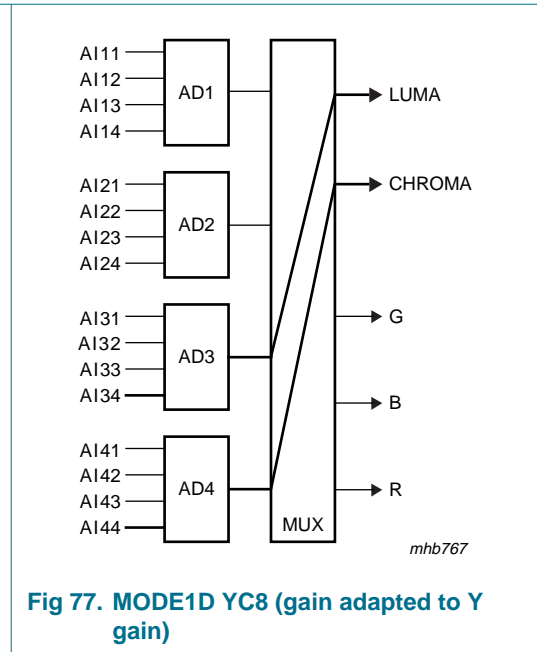
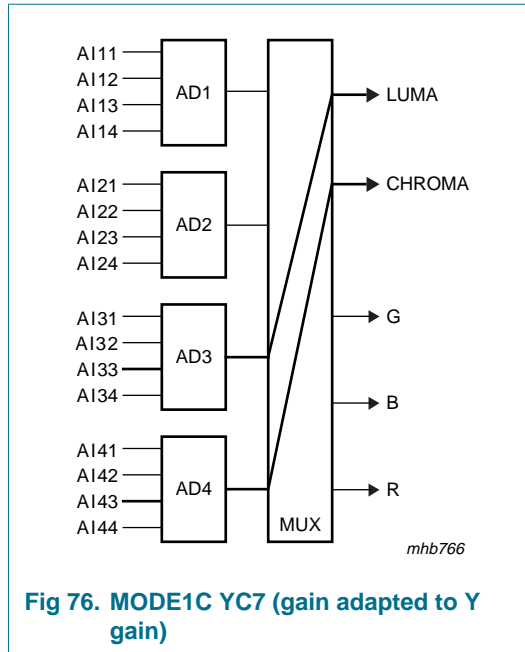
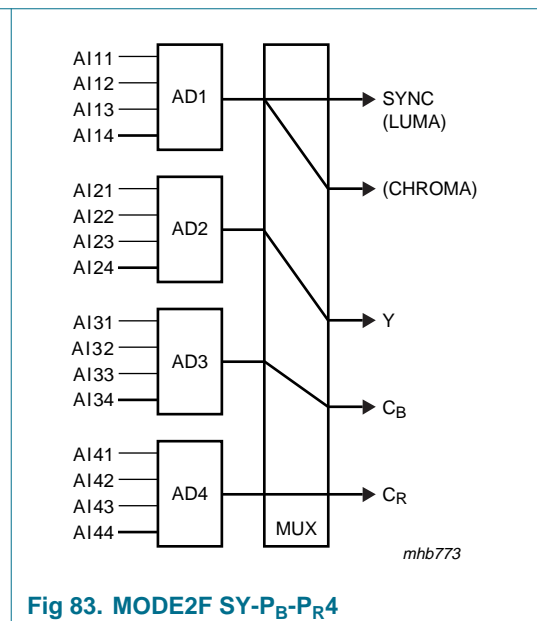
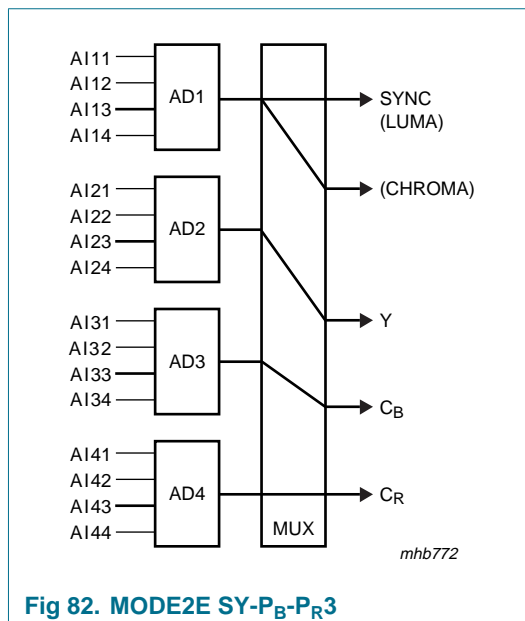
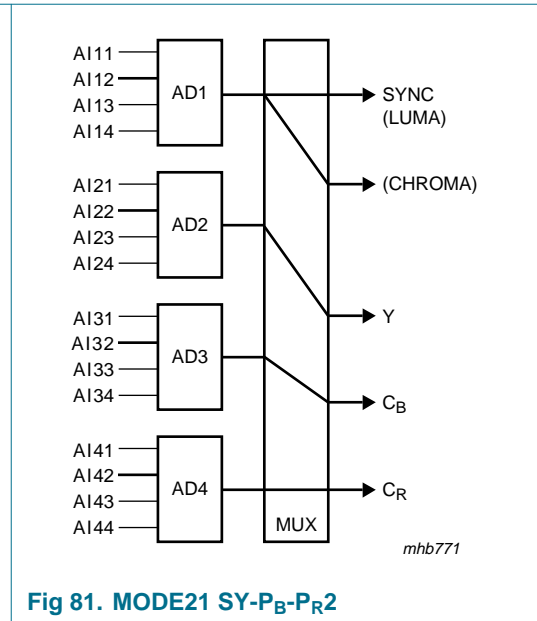
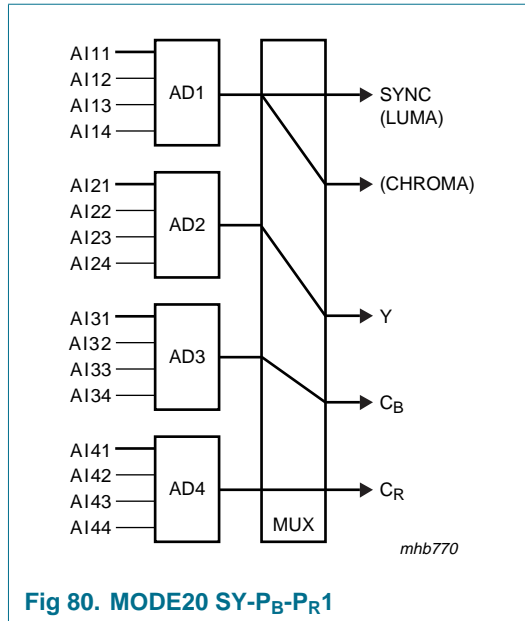
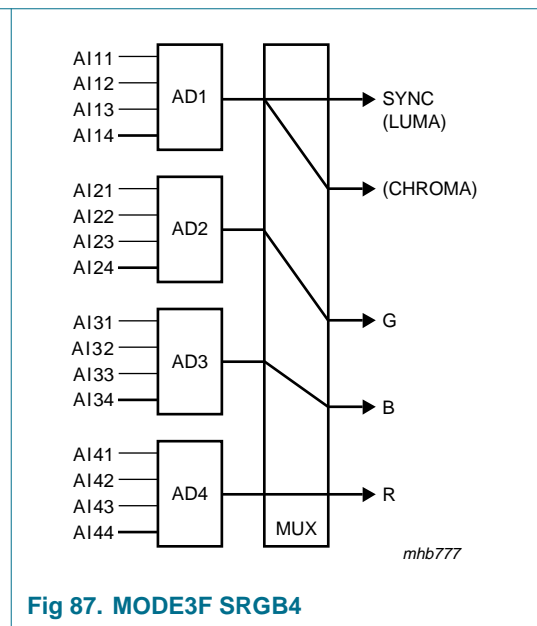
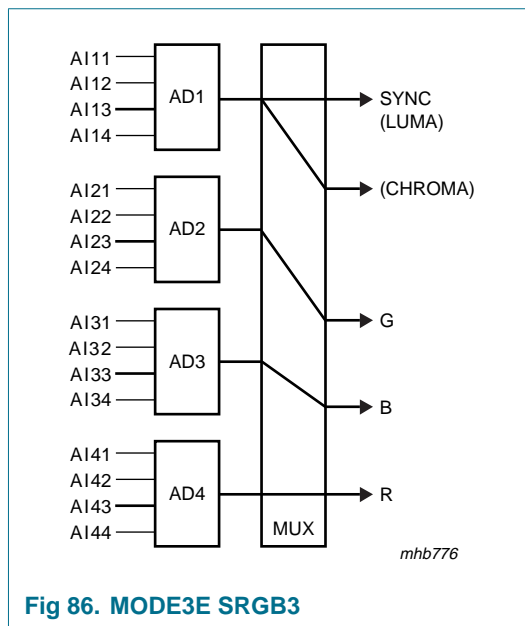
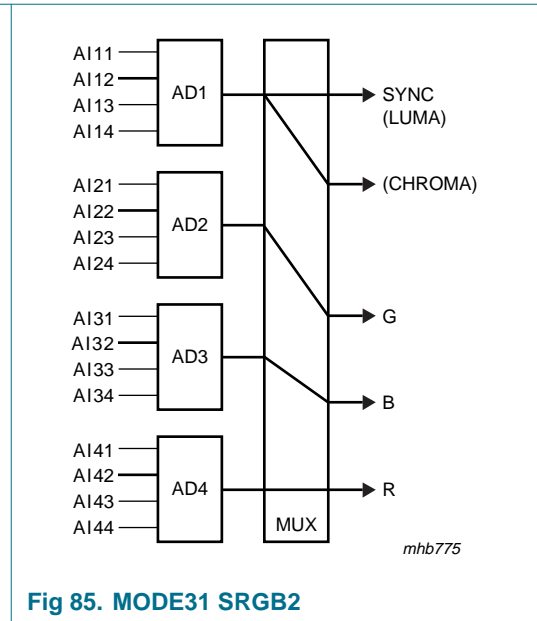
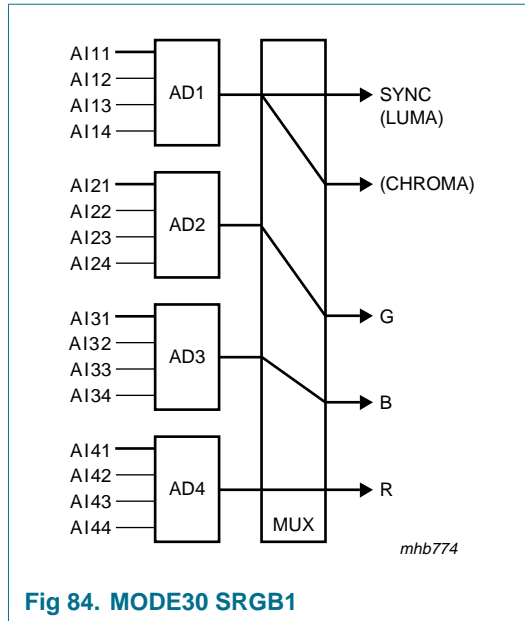

Fig 71. MODE17 YC6 (gain → GAI2 level)









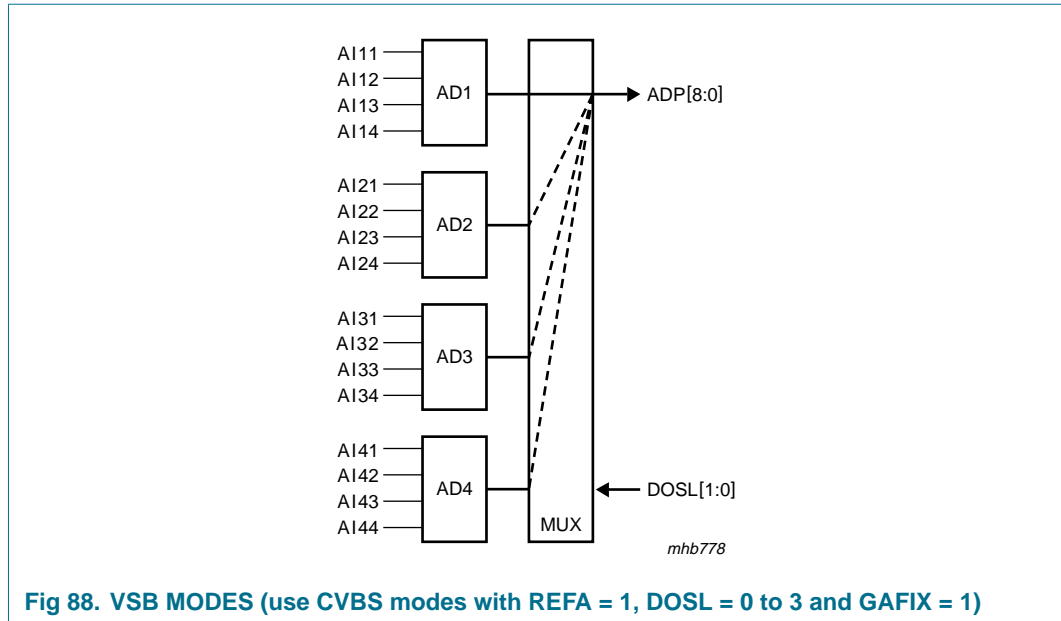

10.2.4 Subaddress 03h

Table 41: Analog input control 2 (AICO2); 03h[6:0]

Bit	Description	Symbol	Value	Function
D6	HL not reference select	HLNRS	0	normal clamping if decoder is in unlocked state
			1	reference select if decoder is in unlocked state
D5	AGC hold during vertical blanking period	VBSL	0	short vertical blanking (AGC disabled during equalization and serration pulses); recommended setting
			1	long vertical blanking (AGC disabled from start of pre-equalization pulses until start of active video (line 22 for 60 Hz, line 24 for 50 Hz))
D4	color peak off	CPOFF	0	color peak control active (AD signal is attenuated, if maximum input level is exceeded, avoids clipping effects on screen)
			1	color peak off
D3	automatic gain control integration	HOLDG	0	AGC active
			1	AGC integration hold (freeze)
D2	gain control fix	GAFIX	0	automatic gain controlled by MODE5 to MODE0
			1	gain is user programmable via GAI[17:10] and GAI[27:20]
D1	static gain control channel 2 sign bit	GAI28	see Table 43	
D0	static gain control channel 1 sign bit	GAI18	see Table 42	

10.2.5 Subaddress 04h

Table 42: Analog input control 3 (AICO3); static gain control channel 1; 03h[0] and 04h[7:0]

Decimal value	Gain (dB)	Sign bit 03h[0]	Control bits D7 to D0								
			GAI18	GAI17	GAI16	GAI15	GAI14	GAI13	GAI12	GAI11	GAI10
0...	-3	0	0	0	0	0	0	0	0	0	0
...144	0	0	1	0	0	1	0	0	0	0	0
145...	0	0	1	0	0	1	0	0	0	0	1
...511	+6	1	1	1	1	1	1	1	1	1	1

10.2.6 Subaddress 05h

Table 43: Analog input control 4 (AICO4); static gain control channel 2; 03h[1] and 05h[7:0]

Decimal value	Gain (dB)	Sign bit 03h[1]	Control bits D7 to D0								
			GAI28	GAI27	GAI26	GAI25	GAI24	GAI23	GAI22	GAI21	GAI20
0...	-3	0	0	0	0	0	0	0	0	0	0
...144	0	0	1	0	0	1	0	0	0	0	0
145...	0	0	1	0	0	1	0	0	0	0	1
...511	+6	1	1	1	1	1	1	1	1	1	1

10.2.7 Subaddress 06h

Table 44: Horizontal sync start; 06h[7:0]

Delay time (step size = 8/LLC)	Control bits D7 to D0							
	HSB7	HSB6	HSB5	HSB4	HSB3	HSB2	HSB1	HSB0
-128...-109 (50 Hz)	forbidden (outside available central counter range)							
-128...-108 (60 Hz)	forbidden (outside available central counter range)							
-108 (50 Hz)...	1	0	0	1	0	1	0	0
-107 (60 Hz)...	1	0	0	1	0	1	0	1
...108 (50 Hz)	0	1	1	0	1	1	0	0
...107 (60 Hz)	0	1	1	0	1	0	1	1
109...127 (50 Hz)	forbidden (outside available central counter range)							
108...127 (60 Hz)	forbidden (outside available central counter range)							

10.2.8 Subaddress 07h

Table 45: Horizontal sync stop; 07h[7:0]

Delay time (step size = 8/LLC)	Control bits D7 to D0							
	HSS7	HSS6	HSS5	HSS4	HSS3	HSS2	HSS1	HSS0
-128...-109 (50 Hz)	forbidden (outside available central counter range)							
-128...-108 (60 Hz)	forbidden (outside available central counter range)							
-108 (50 Hz)...	1	0	0	1	0	1	0	0
-107 (60 Hz)...	1	0	0	1	0	1	0	1
...108 (50 Hz)	0	1	1	0	1	1	0	0
...107 (60 Hz)	0	1	1	0	1	0	1	1
109...127 (50 Hz)	forbidden (outside available central counter range)							
108...127 (60 Hz)	forbidden (outside available central counter range)							

10.2.9 Subaddress 08h

Table 46: Sync control; 08h[7:0]

Bit	Description	Symbol	Value	Function
D7	automatic field detection	AUFD	0	field state directly controlled via FSEL
			1	automatic field detection; recommended setting
D6	field selection; active if AUFD = 0	FSEL	0	50 Hz, 625 lines
			1	60 Hz, 525 lines
D5	forced ODD/EVEN toggle	FOET	0	ODD/EVEN signal toggles only with interlaced source
			1	ODD/EVEN signal toggles fieldwise even if source is non-interlaced
D[4:3]	horizontal time constant selection	HTC[1:0]	00	TV mode, recommended for poor quality TV signals only; do not use for new applications
			01	VTR mode, recommended if a deflection control circuit is directly connected to the SAF7118
			10	reserved
			11	fast locking mode; recommended setting
D2	horizontal PLL	HPLL	0	PLL closed
			1	PLL open; horizontal frequency fixed
D[1:0]	vertical noise reduction	VNOI[1:0]	00	normal mode; recommended setting
			01	fast mode, applicable for stable sources only; automatic field detection (AUFD) must be disabled
			10	free running mode
			11	vertical noise reduction bypassed

10.2.10 Subaddress 09h

Table 47: Luminance control; 09h[7:0]

Bit	Description	Symbol	Value	Function
D7	chrominance trap/comb filter bypass	BYPS	0	chrominance trap or luminance comb filter active; default for CVBS mode
			1	chrominance trap or luminance comb filter bypassed; default for S-video mode
D6	adaptive luminance comb filter	YCOMB	0	disabled (= chrominance trap enabled, if BYPS = 0)
			1	active, if BYPS = 0
D5	processing delay in non comb filter mode	LDEL	0	processing delay is equal to internal pipelining delay; recommended setting
			1	one (NTSC standards) or two (PAL standards) video lines additional processing delay
D4	remodulation bandwidth for luminance; see Figure 14 to Figure 17	LUBW	0	small remodulation bandwidth (narrow chroma notch ⇒ higher luminance bandwidth)
			1	large remodulation bandwidth (wider chroma notch ⇒ smaller luminance bandwidth)
D[3:0]	sharpness control, luminance filter characteristic; see Figure 18	LUF[3:0]	0001	resolution enhancement filter 8.0 dB at 4.1 MHz
			0010	resolution enhancement filter 6.8 dB at 4.1 MHz
			0011	resolution enhancement filter 5.1 dB at 4.1 MHz
			0100	resolution enhancement filter 4.1 dB at 4.1 MHz
			0101	resolution enhancement filter 3.0 dB at 4.1 MHz
			0110	resolution enhancement filter 2.3 dB at 4.1 MHz
			0111	resolution enhancement filter 1.6 dB at 4.1 MHz
			0000	plain
			1000	low-pass filter 2 dB at 4.1 MHz
			1001	low-pass filter 3 dB at 4.1 MHz
			1010	low-pass filter 3 dB at 3.3 MHz; 4 dB at 4.1 MHz
			1011	low-pass filter 3 dB at 2.6 MHz; 8 dB at 4.1 MHz
			1100	low-pass filter 3 dB at 2.4 MHz; 14 dB at 4.1 MHz
1101	low-pass filter 3 dB at 2.2 MHz; notch at 3.4 MHz			
1110	low-pass filter 3 dB at 1.9 MHz; notch at 3.0 MHz			
1111	low-pass filter 3 dB at 1.7 MHz; notch at 2.5 MHz			

10.2.11 Subaddress 0Ah

Table 48: Luminance brightness control: decoder part; 0Ah[7:0]

Offset	Control bits D7 to D0							
	DBR17	DBR16	DBR15	DBR14	DBR13	DBR12	DBR11	DBR10
255 (bright)	1	1	1	1	1	1	1	1
128 (ITU level)	1	0	0	0	0	0	0	0
0 (dark)	0	0	0	0	0	0	0	0

10.2.12 Subaddress 0Bh

Table 49: Luminance contrast control: decoder part; 0Bh[7:0]

Gain	Control bits D7 to D0							
	DCON7	DCON6	DCON5	DCON4	DCON3	DCON2	DCON1	DCON0
1.984 (maximum)	0	1	1	1	1	1	1	1
1.063 (ITU level)	0	1	0	0	0	1	0	0
1.0	0	1	0	0	0	0	0	0
0 (luminance off)	0	0	0	0	0	0	0	0
-1 (inverse luminance)	1	1	0	0	0	0	0	0
-2 (inverse luminance)	1	0	0	0	0	0	0	0

10.2.13 Subaddress 0Ch

Table 50: Chrominance saturation control: decoder part; 0Ch[7:0]

Gain	Control bits D7 to D0							
	DSAT7	DSAT6	DSAT5	DSAT4	DSAT3	DSAT2	DSAT1	DSAT0
1.984 (maximum)	0	1	1	1	1	1	1	1
1.0 (ITU level)	0	1	0	0	0	0	0	0
0 (color off)	0	0	0	0	0	0	0	0
-1 (inverse chrominance)	1	1	0	0	0	0	0	0
-2 (inverse chrominance)	1	0	0	0	0	0	0	0

10.2.14 Subaddress 0Dh

Table 51: Chrominance hue control; 0Dh[7:0]

Hue phase (deg)	Control bits D7 to D0							
	HUEC7	HUEC6	HUEC5	HUEC4	HUEC3	HUEC2	HUEC1	HUEC0
+178.6...	0	1	1	1	1	1	1	1
...0...	0	0	0	0	0	0	0	0
...-180	1	0	0	0	0	0	0	0

10.2.15 Subaddress 0Eh

Table 52: Chrominance control 1; 0Eh[7:0]

Bit	Description	Symbol	Value	Function	
				50 Hz/625 lines	60 Hz/525 lines
D7	clear DTO	CDTO	0	disabled	
			1	Every time CDTO is set, the internal subcarrier DTO phase is reset to 0° and the RTCO output generates a logic 0 at time slot 68 (see document "RTC Functional Description", available on request). So an identical subcarrier phase can be generated by an external device (e.g. an encoder); if a DTO reset is programmed via CDTO it has always to be executed in the following way: <ol style="list-style-type: none"> 1. Set CDTO = 0 2. Set CDTO = 1 	

Table 52: Chrominance control 1; 0Eh[7:0]...continued

Bit	Description	Symbol	Value	Function	
				50 Hz/625 lines	60 Hz/525 lines
D[6:4]	color standard selection in non AUTO mode	CSTD[2:0]	000	PAL BGDHI (4.43 MHz)	NTSC M (3.58 MHz)
			001	NTSC 4.43 (50 Hz)	PAL 4.43 (60 Hz)
			010	Combination-PAL N (3.58 MHz)	NTSC 4.43 (60 Hz)
			011	NTSC N (3.58 MHz)	PAL M (3.58 MHz)
			100	reserved	NTSC-Japan (3.58 MHz)
			101	SECAM	reserved
			110	reserved; do not use	
			111	reserved; do not use	
D[6:4]	color standard selection in AUTO mode (AUTO mode is selected, if either AUTO0 or AUTO1 is set; see below)	CSTD[2:0]	000	preferred standard [1] is PAL BGDHI (4.43 MHz)	preferred standard [1] is NTSC M (3.58 MHz)
			001	reserved; do not use	
			010	reserved; do not use	
			011	reserved; do not use	
			100	preferred standard [1] is PAL BGDHI (4.43 MHz)	preferred standard [1] is NTSC-Japan (3.58 MHz, no 7.5 IRE offset)
			101	preferred standard [1] is SECAM	preferred standard [1] is NTSC M (3.58 MHz)
			110	reserved; do not use	
			111	reserved; do not use	
D3	disable chrominance vertical filter and PAL phase error correction	DCVF	0	chrominance vertical filter and PAL phase error correction on (during active video lines)	
			1	chrominance vertical filter and PAL phase error correction permanently off	
D2	fast color time constant	FCTC	0	nominal time constant	
			1	fast time constant for special applications (high quality input source, fast chroma lock required, automatic standard detection off)	
14h[2] and 0Eh[1]	automatic chrominance standard detection control	AUTO[1:0]	00	disabled	
			01	active, filter settings and sharpness control are preset to default values according to the detected standard and mode; recommended setting	
			10	active, filter settings are preset to default values according to the detected standard and mode	
			11	active, but no filter presets	
D0	adaptive chrominance comb filter	CCOMB	0	disabled	
			1	active	

[1] The meaning of 'preferred standard' is, that the internal search machine will always give priority to the selected standard, thus the recognition time for these standards is kept short.

10.2.16 Subaddress 0Fh

Table 53: Chrominance gain control; 0Fh[7:0]

Bit	Description	Symbol	Value	Function
D7	automatic chrominance gain control	ACGC	0	on; recommended setting
			1	programmable gain via CGAIN6 to CGAIN0; need to be set for SECAM standard
D[6:0]	chrominance gain value (if ACGC is set to logic 1)	CGAIN[6:0]	000 0000	minimum gain (0.5)
			010 0100	nominal gain (1.125)
			111 1111	maximum gain (7.5)

10.2.17 Subaddress 10h

Table 54: Chrominance control 2; 10h[7:0]

Bit	Description	Symbol	Value	Function
D[7:6]	fine offset adjustment B – Y component	OFFU[1:0]	00	0 LSB
			01	$\frac{1}{4}$ LSB
			10	$\frac{1}{2}$ LSB
			11	$\frac{3}{4}$ LSB
D[5:4]	fine offset adjustment R – Y component	OFFV[1:0]	00	0 LSB
			01	$\frac{1}{4}$ LSB
			10	$\frac{1}{2}$ LSB
			11	$\frac{3}{4}$ LSB
D3	chrominance bandwidth; see Figure 12 and Figure 13	CHBW	0	small
			1	wide
D[2:0]	combined luminance/chrominance bandwidth adjustment; see Figure 12 to Figure 18	LCBW[2:0]	000	smallest chrominance bandwidth/largest luminance bandwidth
		 to ...
			111	largest chrominance bandwidth/smallest luminance bandwidth

10.2.18 Subaddress 11h

Table 55: Mode/delay control; 11h[7:0]

Bit	Description	Symbol	Value	Function
D7	color on	COLO	0	automatic color killer enabled; recommended setting
			1	color forced on
D6	polarity of RTS1 output signal	RTP1	0	non-inverted
			1	inverted
D[5:4]	fine position of HS (steps in 2/LLC)	HDEL[1:0]	00	0
			01	1
			10	2
			11	3
D3	polarity of RTS0 output signal	RTP0	0	non-inverted
			1	inverted

Table 55: Mode/delay control; 11h[7:0]...continued

Bit	Description	Symbol	Value	Function
D[2:0]	luminance delay compensation (steps in 2/LLC)	YDEL[2:0]	100	-4...
			000	...0...
			011	...3

10.2.19 Subaddress 12h

Table 56: RT signal control: RTS0 output; 12h[3:0]

The polarity of any signal on RTS0 can be inverted via RTP0[11h[3]].

RTS0 output	RTSE03	RTSE02	RTSE01	RTSE00
3-state	0	0	0	0
Constant LOW	0	0	0	1
CREF (13.5 MHz toggling pulse; see Figure 32)	0	0	1	0
CREF2 (6.75 MHz toggling pulse; see Figure 32)	0	0	1	1
HL; horizontal lock indicator [1]: HL = 0: unlocked HL = 1: locked	0	1	0	0
VL; vertical and horizontal lock: VL = 0: unlocked VL = 1: locked	0	1	0	1
DL; vertical and horizontal lock and color detected: DL = 0: unlocked DL = 1: locked	0	1	1	0
Reserved	0	1	1	1
HREF, horizontal reference signal; indicates 720 pixels valid data on the expansion port. The positive slope marks the beginning of a new active line. HREF is also generated during the vertical blanking interval (see Figure 32).	1	0	0	0
HS: Programmable width in LLC8 steps via HSB[7:0] 06h[7:0] and HSS[7:0] 07h[7:0] Fine position adjustment in LLC2 steps via HDEL[1:0] 11h[5:4] (see Figure 32)	1	0	0	1
HQ; HREF gated with VGATE	1	0	1	0
Reserved	1	0	1	1
V123; vertical sync (see vertical timing diagrams Figure 30 and Figure 31)	1	1	0	0
VGATE; programmable via VSTA[8:0] 17h[0] 15h[7:0], VSTO[8:0] 17h[1] 16h[7:0] and VGPS[17h[2]]	1	1	0	1
LSBs of the 9-bit ADCs	1	1	1	0
FID; position programmable via VSTA[8:0] 17h[0] 15h[7:0]; see vertical timing diagrams Figure 30 and Figure 31	1	1	1	1

[1] Function of HL is selectable via HLSEL[13h[3]]:
HLSEL = 0: HL is standard horizontal lock indicator.
HLSEL = 1: HL is fast horizontal lock indicator (use is not recommended for sources with unstable timebase e.g. VCRs).

Table 57: RT signal control: RTS1 output; 12h[7:4]

The polarity of any signal on RTS1 can be inverted via RTP1[11h[6]].

RTS1 output	RTSE13	RTSE12	RTSE11	RTSE10
3-state	0	0	0	0
Constant LOW	0	0	0	1
CREF (13.5 MHz toggling pulse; see Figure 32)	0	0	1	0
CREF2 (6.75 MHz toggling pulse; see Figure 32)	0	0	1	1
HL; horizontal lock indicator ^[1] : HL = 0: unlocked HL = 1: locked	0	1	0	0
VL; vertical and horizontal lock: VL = 0: unlocked VL = 1: locked	0	1	0	1
DL; vertical and horizontal lock and color detected: DL = 0: unlocked DL = 1: locked	0	1	1	0
Reserved	0	1	1	1
HREF, horizontal reference signal; indicates 720 pixels valid data on the expansion port. The positive slope marks the beginning of a new active line. HREF is also generated during the vertical blanking interval (see Figure 32).	1	0	0	0
HS: Programmable width in LLC8 steps via HSB[7:0] 06h[7:0] and HSS[7:0] 07h[7:0] Fine position adjustment in LLC2 steps via HDEL[1:0] 11h[5:4] (see Figure 32)	1	0	0	1
HQ; HREF gated with VGATE	1	0	1	0
Reserved	1	0	1	1
V123; vertical sync; see vertical timing diagrams Figure 30 and Figure 31	1	1	0	0
VGATE; programmable via VSTA[8:0] 17h[0] 15h[7:0], VSTO[8:0] 17h[1] 16h[7:0] and VGPS[17h[2]]	1	1	0	1
Reserved	1	1	1	0
FID; position programmable via VSTA[8:0] 17h[0] 15h[7:0]; see vertical timing diagrams Figure 30 and Figure 31	1	1	1	1

[1] Function of HL is selectable via HLSEL[13h[3]]:

HLSEL = 0: HL is standard horizontal lock indicator.

HLSEL = 1: HL is fast horizontal lock indicator (use is not recommended for sources with unstable timebase e.g. VCRs).

10.2.20 Subaddress 13h

Table 58: RT/X port output control; 13h[7:0]

Bit	Description	Symbol	Value	Function
D7	RTCO output enable	RTCE	0	3-state
			1	enabled
D6	X port XRH output selection	XRHS	0	HREF; see Figure 32
			1	HS: Programmable width in LLC8 steps via HSB[7:0] 06h[7:0] and HSS[7:0] 07h[7:0] Fine position adjustment in LLC2 steps via HDEL[1:0] 11h[5:4] (see Figure 32)
D[5:4]	X port XRV output selection	XRVS[1:0]	00	V123 (see Figure 30 and Figure 31)
			01	ITU 656 related field ID (see Figure 30 and Figure 31)
			10	inverted V123
			11	inverted ITU 656 related field ID
D3	horizontal lock indicator selection	HLSEL	0	copy of inverted HLCK status bit (default)
			1	fast horizontal lock indicator (for special applications only)
D[2:0]	XPD7 to XPD0 (port output format selection); see Section 9.5	OFTS[2:0]	000	ITU 656
			001	ITU 656 like format with modified field blanking according to VGATE position (programmable via VSTA[8:0] 17h[0] 15h[7:0], VSTO[8:0] 17h[1] 16h[7:0] and VGPS[17h[2]])
			010	Y-C _B -C _R 4 : 2 : 2 8-bit format (no SAV/EAV codes inserted)
			011	reserved
			100	multiplexed AD2/AD1 or AD4/AD3 bypass (bits D8 to D1) dependent on mode settings (see Section 10.2.3); if two ADCs are selected AD2/AD4 is output at CREF = 1 and AD1/AD3 is output at CREF = 0
			101	multiplexed AD2/AD1 or AD4/AD3 bypass (bits D7 to D0) dependent on mode settings (see Section 10.2.3); if two ADCs are selected AD2/AD4 is output at CREF = 1 and AD1/AD3 is output at CREF = 0
110	reserved			
111	multiplexed ADC MSB/LSB bypass dependent on mode settings; only one ADC should be selected at a time; ADx8 to ADx1 are outputs at CREF = 1 and ADx7 to ADx0 are outputs at CREF = 0			

10.2.21 Subaddress 14h

Table 59: Analog/ADC/auto/compatibility control; 14h[7:0]

Bit	Description	Symbol	Value	Function
D7	compatibility bit for SAA7199	CM99	0	off (default)
			1	on (to be set only if SAA7199 is used for re-encoding in conjunction with RTCO active)
D6	update time interval for AGC value	UPTCV	0	horizontal update (once per line)
			1	vertical update (once per field)
23h[7] and 14h[5:4]	analog test select	AOSL[2:0]	000	AOUT connected to ground
			001	AOUT connected to input AD1
			010	AOUT connected to input AD2
			011	AOUT connected to input AD3
			100	AOUT connected to input AD4
			101	reserved
			110	reserved
			111	AOUT connected to internal test point BPFOUT
D3	XTOUT output enable	XTOUTE	0	XTOUT 3-stated
			1	XTOUT enabled
D2	automatic chrominance standard detection control 1	AUTO1	see Section 10.2.15	
D[1:0]	ADC sample clock phase delay	APCK[1:0]	00	application dependent
			01	application dependent
			10	application dependent
			11	application dependent

10.2.22 Subaddress 15h

Table 60: VGATE start; FID polarity change; 17h[0] and 15h[7:0]

Start of VGATE pulse (LOW-to-HIGH transition) and polarity change of FID pulse, VGPS = 0; see [Figure 30](#) and [Figure 31](#).

Field		Frame line counting	Decimal value	MSB 17h[0]	Control bits D7 to D0							
					VSTA8	VSTA7	VSTA6	VSTA5	VSTA4	VSTA3	VSTA2	VSTA1
50 Hz	1st	1	312	1	0	0	1	1	1	0	0	0
	2nd	314										
	1st	2	0...	0	0	0	0	0	0	0	0	0
	2nd	315										
60 Hz	1st	312	...310	1	0	0	1	1	0	1	1	1
	2nd	625										
	1st	4	262	1	0	0	0	0	0	1	1	0
	2nd	267										
60 Hz	1st	5	0...	0	0	0	0	0	0	0	0	0
	2nd	268										
	1st	265	...260	1	0	0	0	0	0	1	0	1
	2nd	3										

10.2.23 Subaddress 16h

Table 61: VGATE stop; 17h[1] and 16h[7:0]
 Stop of VGATE pulse (HIGH-to-LOW transition), VGPS = 0; see [Figure 30](#) and [Figure 31](#).

Field	Frame line counting	Decimal value	MSB 17h[1]	Control bits D7 to D0								
			VSTO8	VSTO7	VSTO6	VSTO5	VSTO4	VSTO3	VSTO2	VSTO1	VSTO0	
50 Hz	1st	1	312	1	0	0	1	1	1	0	0	0
	2nd	314										
	1st	2	0...	0	0	0	0	0	0	0	0	0
	2nd	315										
	1st	312	...310	1	0	0	1	1	0	1	1	1
	2nd	625										
60 Hz	1st	4	262	1	0	0	0	0	0	1	1	0
	2nd	267										
	1st	5	0...	0	0	0	0	0	0	0	0	0
	2nd	268										
	1st	265	...260	1	0	0	0	0	0	1	0	1
	2nd	3										

10.2.24 Subaddress 17h

Table 62: Miscellaneous/VGATE MSBs; 17h[7:0]

Bit	Description	Symbol	Value	Function
D7	LLC output enable	LLCE	0	enable
			1	3-state
D6	LLC2 output enable	LLC2E	0	enable
			1	3-state
D[5:3]	standard detection search loop latency	LATY[2:0]	000	reserved
			001	one field
			010	two fields
			011	three fields; recommended setting
		 to ...
			111	seven fields
D2	alternative VGATE position	VGPS	0	VGATE position according to Table 60 and Table 61
			1	VGATE occurs one line earlier during field 2
D1	MSB VGATE stop	VSTO8	see Table 61	
D0	MSB VGATE start	VSTA8	see Table 60	

10.2.25 Subaddress 18h

Table 63: Raw data gain control; RAWG[7:0] 18h[7:0]; see Figure 20

Gain	Control bits D7 to D0							
	RAWG7	RAWG6	RAWG5	RAWG4	RAWG3	RAWG2	RAWG1	RAWG0
255 (double amplitude)	0	1	1	1	1	1	1	1
128 (nominal level)	0	1	0	0	0	0	0	0
0 (off)	0	0	0	0	0	0	0	0

10.2.26 Subaddress 19h

Table 64: Raw data offset control; RAWO[7:0] 19h[7:0]; see Figure 20

Offset	Control bits D7 to D0							
	RAWO7	RAWO6	RAWO5	RAWO4	RAWO3	RAWO2	RAWO1	RAWO0
-128 LSB	0	0	0	0	0	0	0	0
0 LSB	1	0	0	0	0	0	0	0
+128 LSB	1	1	1	1	1	1	1	1

10.2.27 Subaddress 1Eh

Table 65: Status byte 1 video decoder; 1Eh[6:0]; read only register

Bit	Description	I ² C-bus control bit	Value	Function
D6	status bit for locked horizontal frequency	HLCK	0	locked
			1	unlocked
D5	slow time constant active in WIPA mode	SLTCA	0	not active
			1	active
D4	gain value for active luminance channel is limited; maximum (top)	GLIMT	0	not active
			1	active
D3	gain value for active luminance channel is limited; minimum (bottom)	GLIMB	0	not active
			1	active
D2	white peak loop is activated	WIPA	0	not active
			1	active
D[1:0]	detected color standard	DCSTD[1:0]	00	no color (black-white)
			01	NTSC
			10	PAL
			11	SECAM

10.2.28 Subaddress 1Fh

Table 66: Status byte 2 video decoder; 1Fh[7:5] and 1Fh[3:0]; read only register

Bit	Description	I ² C-bus control bit	Value	Function
D7	status bit for interlace detection	INTL	0	non-interlaced
			1	interlaced
D6	status bit for horizontal and vertical loop	HLVLN	0	both loops locked
			1	unlocked
D5	identification bit for detected field frequency	FIDT	0	50 Hz
			1	60 Hz
D3	Macrovision encoded color stripe burst type 3 (4 line version) detected	TYPE3	0	not active
			1	active
D2	Macrovision encoded color stripe burst detected (any type)	COLSTR	0	not active
			1	active
D1	copy protected source detected according to Macrovision version up to 7.01	COPRO	0	not active
			1	active
D0	ready for capture (all internal loops locked)	RDCAP	0	not active
			1	active

10.3 Programming register RGB/Y-P_B-P_R component input processing

10.3.1 Subaddress 23h

Table 67: Analog input control 5 (AICO5); 23h[7:4] and 23h[2:0]

Bit	Description	Symbol	Value	Function
D7	analog output select	AOSL2	see Table 59	
D6	AD port output enable	ADPE	0	AD port is set to 3-state
			1	AD port is enabled
D5	ADC clock selector	EXCLK	0	all ADCs are clocked by the internal generated line-locked clock
			1	all ADCs are clocked by the external input clock on CLKEXT
D4	clamping/reference selection for all ADCs	REFA	0	clamping is dependent on HLNRS[03h[6]]
			1	reference selection (input signal is pulled into ADC range)
D2	enable external source switch indicator input EXMCLR	EXMCE	0	disabled
			1	enabled (any slope on EXMCLR input will reset the internal gain control loop)
D1	static gain control channel 2 sign bit	GAI48	see Table 69	
D0	static gain control channel 1 sign bit	GAI38	see Table 68	

10.3.2 Subaddress 24h

Table 68: Analog input control 6 (AICO6): static gain control channel 3; 23h[0] and 24h[7:0]

Decimal value	Gain (dB)	Sign bit 23h[0]	Control bits D7 to D0								
		GAI38	GAI37	GAI36	GAI35	GAI34	GAI33	GAI32	GAI31	GAI30	
0...	-3	0	0	0	0	0	0	0	0	0	0
...144	0	0	1	0	0	1	0	0	0	0	0
145...	0	0	1	0	0	1	0	0	0	0	1
...511	+6	1	1	1	1	1	1	1	1	1	1

10.3.3 Subaddress 25h

Table 69: Analog input control 7 (AICO7): static gain control channel 4; 23h[1] and 25h[7:0]

Decimal value	Gain (dB)	Sign bit 23h[1]	Control bits D7 to D0								
		GAI48	GAI47	GAI46	GAI45	GAI44	GAI43	GAI42	GAI41	GAI40	
0...	-3	0	0	0	0	0	0	0	0	0	0
...144	0	0	1	0	0	1	0	0	0	0	0
145...	0	0	1	0	0	1	0	0	0	0	1
...511	+6	1	1	1	1	1	1	1	1	1	1

10.3.4 Subaddress 29h

Table 70: Component delay/fast switch control; 29h[7:0]

Bit	Description	Symbol	Value	Function
D7	fast switch enable	FSWE	0	disabled
			1	pixelwise switching between decoded CVBS signal and component input signal is enabled (should only be used for component sources synchronous to CVBS input)
D6	fast switch input polarity if FSWE = 1 static selection if FSWE = 0	FSWI	0	FSW = 0: decoded CVBS signal, FSW = 1: component signal
			1	FSW = 1: decoded CVBS signal, FSW = 0: component signal
			0	for modes 00h to 1Fh
			1	for modes 20h to 3Fh
D[5:4]	fast switch input delay adjustment relative to component input signal	FSWDL[1:0]	00	0 pixel (default)
			01	+1 pixel
			10	-2 pixel
			11	-1 pixel
D3	component luminance peaking	CMFI	0	disabled
			1	enabled (+1.5 dB at 5 MHz)

Table 70: Component delay/fast switch control; 29h[7:0]...continued

Bit	Description	Symbol	Value	Function
D[2:0]	component input delay adjustment relative to decoded CVBS signal	CPDL[2:0]	000	0 pixel (default)
			001	+4 pixel
			010	+8 pixel
			011	+12 pixel
			100	-16 pixel
			101	-12 pixel
			110	-8 pixel
			111	-4 pixel

10.3.5 Subaddress 2Ah

Table 71: Luminance brightness control component part; 2Ah[7:0]

Offset	Control bits D7 to D0							
	CBRI7	CBRI6	CBRI5	CBRI4	CBRI3	CBRI2	CBRI1	CBRI0
255 (bright)	1	1	1	1	1	1	1	1
128 (ITU level)	1	0	0	0	0	0	0	0
0 (dark)	0	0	0	0	0	0	0	0

10.3.6 Subaddress 2Bh

Table 72: Luminance contrast control component part; 2Bh[7:0]

Gain	Control bits D7 to D0							
	CCON7	CCON6	CCON5	CCON4	CCON3	CCON2	CCON1	CCON0
1.984 (maximum)	0	1	1	1	1	1	1	1
1.0 (ITU level)	0	1	0	0	0	0	0	0
0 (luminance off)	0	0	0	0	0	0	0	0
-1.0 (inverse luminance)	1	1	0	0	0	0	0	0
-2.0 (inverse luminance)	1	0	0	0	0	0	0	0

10.3.7 Subaddress 2Ch

Table 73: Chrominance saturation control component part; 2Ch[7:0]

Gain	Control bits D7 to D0							
	CSAT7	CSAT6	CSAT5	CSAT4	CSAT3	CSAT2	CSAT1	CSAT0
1.984 (maximum)	0	1	1	1	1	1	1	1
1.0 (ITU level)	0	1	0	0	0	0	0	0
0 (color off)	0	0	0	0	0	0	0	0
-1.0 (inverse chrominance)	1	1	0	0	0	0	0	0
-2.0 (inverse chrominance)	1	0	0	0	0	0	0	0

10.4 Interrupt mask registers

See also [Section 9.4](#).

10.4.1 Subaddress 2Dh

Table 74: Interrupt mask 1; 2Dh[4:2] and 2Dh[1]

Bit	Description	Symbol	Value	Function
D4	interrupt enable 'VPS signal detected/lost' (corresponding flag: 60h[4])	MVPSV	0	disabled
			1	enabled
D3	interrupt enable 'PALplus detected/lost' (corresponding flag: 60h[3])	MPPV	0	disabled
			1	enabled
D2	interrupt enable 'closed caption detected/lost' (corresponding flag: 60h[2])	MCCV	0	disabled
			1	enabled
D0	interrupt enable 'error output formatter' (corresponding flag: 8Fh[2])	MERROF	0	disabled
			1	enabled

10.4.2 Subaddress 2Eh

Table 75: Interrupt mask 2; 2Eh[6] and 2Eh[1:0]

Bit	Description	Symbol	Value	Function
D6	interrupt enable 'horizontal PLL locked/unlocked' (corresponding flag: 1Eh[6])	MHLCK	0	disabled
			1	enabled
D1	interrupt enable 'color standard changed 1' (corresponding flag: 1Eh[1])	MDCSTD1	0	disabled
			1	enabled
D0	interrupt enable 'color standard changed 0' (corresponding flag: 1Eh[0])	MDCSTD0	0	disabled
			1	enabled

10.4.3 Subaddress 2Fh

Table 76: Interrupt mask 3; 2Fh[7:5] and 2Fh[3:0]

Bit	Description	Symbol	Value	Function
D7	interrupt enable 'interlaced/non-interlaced source' (corresponding flag: 1Fh[7])	MINTL	0	disabled
			1	enabled
D6	interrupt enable 'horizontal and vertical lock reached/lost' (corresponding flag: 1Fh[6])	MHLVLN	0	disabled
			1	enabled
D5	interrupt enable 'field frequency has changed' (corresponding flag: 1Fh[5])	MFIDT	0	disabled
			1	enabled
D3	interrupt enable 'color stripe type 3 burst detected/lost' (corresponding flag: 1Fh[3])	MTYPE3	0	disabled
			1	enabled
D2	interrupt enable 'color stripe burst (any type) detected/lost' (corresponding flag: 1Fh[2])	MCOLSTR	0	disabled
			1	enabled
D1	interrupt enable 'copy protected signal found/lost' (corresponding flag: 1Fh[1])	MCOPRO	0	disabled
			1	enabled
D0	interrupt enable 'ready for capture/not ready' (corresponding flag: 1Fh[0])	MRDCAP	0	disabled
			1	enabled

10.5 Programming register audio clock generation

See equations in [Section 8.7](#) and examples in [Table 22](#) and [Table 23](#).

10.5.1 Subaddresses 30h to 32h

Table 77: Audio master clock (AMCLK) cycles per field

Subaddress	Control bits D7 to D0							
30h	ACPF7	ACPF6	ACPF5	ACPF4	ACPF3	ACPF2	ACPF1	ACPF0
31h	ACPF15	ACPF14	ACPF13	ACPF12	ACPF11	ACPF10	ACPF9	ACPF8
32h	-	-	-	-	-	-	ACPF17	ACPF16

10.5.2 Subaddresses 34h to 36h

Table 78: Audio master clock (AMCLK) nominal increment

Subaddress	Control bits D7 to D0							
34h	ACNI7	ACNI6	ACNI5	ACNI4	ACNI3	ACNI2	ACNI1	ACNI0
35h	ACNI15	ACNI14	ACNI13	ACNI12	ACNI11	ACNI10	ACNI9	ACNI8
36h	-	-	ACNI21	ACNI20	ACNI19	ACNI18	ACNI17	ACNI16

10.5.3 Subaddress 38h

Table 79: Clock ratio audio master clock (AMXCLK) to serial bit clock (ASCLK)

Subaddress	Control bits D7 to D0							
38h	-	-	SDIV5	SDIV4	SDIV3	SDIV2	SDIV1	SDIV0

10.5.4 Subaddress 39h

Table 80: Clock ratio serial bit clock (ASCLK) to channel select clock (ALRCLK)

Subaddress	Control bits D7 to D0							
39h	-	-	LRDIV5	LRDIV4	LRDIV3	LRDIV2	LRDIV1	LRDIV0

10.5.5 Subaddress 3Ah

Table 81: Audio clock control; 3Ah[3:0]

Bit	Description	Symbol	Value	Function
D3	audio PLL modes	APLL	0	PLL active, AMCLK is field-locked
			1	PLL open, AMCLK is free-running
D2	audio master clock vertical reference	AMVR	0	vertical reference pulse is taken from internal decoder
			1	vertical reference is taken from XRV input (expansion port)
D1	ALRCLK phase	LRPH	0	ALRCLK edges triggered by falling edges of ASCLK
			1	ALRCLK edges triggered by rising edges of ASCLK
D0	ASCLK phase	SCPH	0	ASCLK edges triggered by falling edges of AMCLK
			1	ASCLK edges triggered by rising edges of AMCLK

10.6 Programming register VBI data slicer

10.6.1 Subaddress 40h

Table 82: Slicer control 1; 40h[6:4]

Bit	Description	Symbol	Value	Function
D6	Hamming check	HAM_N	0	Hamming check for 2 bytes after framing code, dependent on data type (default)
			1	no Hamming check
D5	framing code error	FCE	0	one framing code error allowed
			1	no framing code errors allowed
D4	amplitude searching	HUNT_N	0	amplitude searching active (default)
			1	amplitude searching stopped

10.6.2 Subaddresses 41h to 57h

Table 83: Line control register; LCR2 to LCR24 (41h to 57h)

See [Section 8.3](#) and [Section 8.5](#).

Name	Description	Framing code	D[7:4] (41h to 57h)	D[3:0] (41h to 57h)
			DT[3:0] 62h[3:0] (field 1)	DT[3:0] 62h[3:0] (field 2)
WST625	teletext EuroWST, CCST	27h	0000	0000
CC625	European closed caption	001	0001	0001
VPS	video programming service	9951h	0010	0010
WSS	wide screen signalling bits	1E 3C1Fh	0011	0011
WST525	US teletext (WST)	27h	0100	0100
CC525	US closed caption (line 21)	001	0101	0101
Test line	video component signal, VBI region	-	0110	0110
Intercast	raw data	-	0111	0111
General text	teletext	programmable	1000	1000
VITC625	VITC/EBU time codes (Europe)	programmable	1001	1001
VITC525	VITC/SMPTE time codes (USA)	programmable	1010	1010
Reserved	reserved	-	1011	1011
NABTS	US NABTS	-	1100	1100
Japtext	MOJI (Japanese)	programmable (A7h)	1101	1101
JFS	Japanese format switch (L20/22)	programmable	1110	1110
Active video	video component signal, active video region (default)	-	1111	1111

10.6.3 Subaddress 58h

Table 84: Programmable framing code; slicer set 58h[7:0]

According to [Table 15](#) and [Table 83](#).

Framing code for programmable data types	Control bits D7 to D0
Default value	FC[7:0] = 40h

10.6.4 Subaddress 59h

Table 85: Horizontal offset for slicer; slicer set 59h and 5Bh

Horizontal offset	Control bits 5Bh[2:0]	Control bits 59h[7:0]
Recommended value	HOFF[10:8] = 3h	HOFF[7:0] = 47h

10.6.5 Subaddress 5Ah

Table 86: Vertical offset for slicer; slicer set 5Ah and 5Bh

Vertical offset	Control bit 5Bh[4]	Control bits 5Ah[7:0]
	VOFF8	VOFF[7:0]
Minimum value 0	0	00h
Maximum value 312	1	38h
Value for 50 Hz 625 lines input	0	03h
Value for 60 Hz 525 lines input	0	06h

10.6.6 Subaddress 5Bh

Table 87: Field offset, and MSBs for horizontal and vertical offsets; slicer set 5Bh[7:6]

See [Section 10.6.4](#) and [Section 10.6.5](#) for HOFF[10:8] 5Bh[2:0] and VOFF8[5Bh[4]].

Bit	Description	Symbol	Value	Function
D7	field offset	FOFF	0	no modification of internal field indicator (default for 50 Hz 625 lines input sources)
			1	invert field indicator (default for 60 Hz 525 lines input sources)
D6	recode	RECODE	0	leave data unchanged (default)
			1	convert 00h and FFh data bytes into 03h and FCh

10.6.7 Subaddress 5Dh

Table 88: Header and data identification (DID; ITU 656) code control; slicer set 5Dh[7:0]

Bit	Description	Symbol	Value	Function
D7	field ID and V-blank selection for text output (F and V reference selection)	FVREF	0	F and V output of slicer is LCR table dependent
			1	F and V output is taken from decoder real-time signals EVEN_ITU and VBLNK_ITU
D[5:0]	default; DID[5:0] = 00h	DID[5:0]	00 0000	ANC header framing ; see Figure 39 and Table 21
	special cases of DID programming	DID[5:0]	11 1110	DID[5:0] = 3Eh SAV/EAV framing, with FVREF = 1
			11 1111	DID[5:0] = 3Fh SAV/EAV framing, with FVREF = 0

10.6.8 Subaddress 5Eh

Table 89: Sliced data identification (SDID) code; slicer set 5Eh[5:0]

Bit	Description	Symbol	Value	Function
D[5:0]	SDID codes	SDID[5:0]	00h	default

10.6.9 Subaddress 60h

Table 90: Slicer status byte 0; 60h[6:2]; read only register

Bit	Description	Symbol	Value	Function
D6	framing code valid	FC8V	0	no framing code (0 error) in the last frame detected
			1	framing code with 0 error detected
D5	framing code valid	FC7V	0	no framing code (1 error) in the last frame detected
			1	framing code with 1 error detected
D4	VPS valid	VPSV	0	no VPS in the last frame
			1	VPS detected
D3	PALplus valid	PPV	0	no PALplus in the last frame
			1	PALplus detected
D2	closed caption valid	CCV	0	no closed caption in the last frame
			1	closed caption detected

10.6.10 Subaddresses 61h and 62h

Table 91: Slicer status byte 1; 61h[5:0] and slicer status byte 2; 62h[7:0]; read only registers

Subaddress	Bit	Symbol	Description
61h	D5	F21_N	field ID as seen by the VBI slicer; for field 1: D5 = 0
	D[4:0]	LN[8:4]	line number
62h	D[7:4]	LN[3:0]	line number
	D[3:0]	DT[3:0]	data type; according to Table 15

10.7 Programming register interfaces and scaler part

10.7.1 Subaddress 80h

Table 92: Global control 1; global set 80h[6:4] ^[1]

SWRST moved to subaddress 88h[5].

Task enable control	Control bits D6 to D4		
	SMOD	TEB	TEA
Task of register set A is disabled	X	X	0
Task of register set A is enabled	X	X	1
Task of register set B is disabled	X	0	X
Task of register set B is enabled	X	1	X
The scaler window defines the F and V timing of the scaler output	0	X	X
VBI data slicer defines the F and V timing of the scaler output	1	X	X

[1] X = don't care.

Table 93: Global control 1; global set 80h[3:0] ^[1]

I port and scaler back-end clock selection	Control bits D3 to D0			
	ICKS3	ICKS2	ICKS1	ICKS0
ICLK output and back-end clock is line-locked clock LLC from decoder	X	X	0	0
ICLK output and back-end clock is XCLK from X port	X	X	0	1
ICLK output is LLC and back-end clock is LLC2 clock	X	X ^[2]	1	0
Back-end clock is the ICLK input	X	X	1	1
IDQ pin carries the data qualifier	X	0	X	X
IDQ pin carries a gated back-end clock (DQ AND CLK)	X	1	X	X
IDQ generation only for valid data	0	X	X	X
IDQ qualifies valid data inside the scaling region and all data outside the scaling region	1	X	X	X

[1] X = don't care.

[2] Although the ICLKO I/O is independent of ICKS2 and ICKS3, this selection can only be used if ICKS2 = 1.

10.7.2 Subaddresses 83h to 87h

Table 94: X port I/O enable and output clock phase control; global set 83h[5:4]

Output clock phase control	Control bits D5 and D4	
	XPCK1	XPCK0
XCLK default output phase, recommended value	0	0
XCLK output inverted	0	1
XCLK phase shifted by approximately 3 ns	1	0
XCLK output inverted and shifted by approximately 3 ns	1	1

Table 95: X port I/O enable and output clock phase control; global set 83h[2:0] ^[1]

X port I/O enable	Control bits D2 to D0		
	XRQT	XPE1	XPE0
X port output is disabled by software	X	0	0
X port output is enabled by software	X	0	1
X port output is enabled by pin XTRI at logic 0	X	1	0
X port output is enabled by pin XTRI at logic 1	X	1	1
XRDY output signal is A/B task flag from event handler (A = 1)	0	X	X
XRDY output signal is ready signal from scaler path (XRDY = 1 means the SAF7118 is ready to receive data)	1	X	X

[1] X = don't care.

Table 96: I port signal definitions; global set 84h[7:6] and 86h[5]

I port signal definitions	Control bits		
	86h[5]	84h[7:6]	
	IDG02	IDG01	IDG00
IGP0 is output field ID, as defined by OFIDC[90h[6]]	0	0	0
IGP0 is A/B task flag, as defined by CONLH[90h[7]]	0	0	1
IGP0 is sliced data flag, framing the sliced VBI data at the I port	0	1	0

Table 96: I port signal definitions; global set 84h[7:6] and 86h[5]...continued

I port signal definitions	Control bits		
	86h[5]	84h[7:6]	
	IDG02	IDG01	IDG00
IGP0 is set to logic 0 (default polarity)	0	1	1
IGP0 is the output FIFO almost filled flag	1	0	0
IGP0 is the output FIFO overflow flag	1	0	1
IGP0 is the output FIFO almost full flag, level to be programmed in subaddress 86h	1	1	0
IGP0 is the output FIFO almost empty flag, level to be programmed in subaddress 86h	1	1	1

Table 97: I port signal definitions; global set 84h[5:4] and 86h[4]

I port signal definitions	Control bits		
	86h[4]	84h[5:4]	
	IDG12	IDG11	IDG10
IGP1 is output field ID, as defined by OFIDC[90h[6]]	0	0	0
IGP1 is A/B task flag, as defined by CONLH[90h[7]]	0	0	1
IGP1 is sliced data flag, framing the sliced VBI data at the I port	0	1	0
IGP1 is set to logic 0 (default polarity)	0	1	1
IGP1 is the output FIFO almost filled flag	1	0	0
IGP1 is the output FIFO overflow flag	1	0	1
IGP1 is the output FIFO almost full flag, level to be programmed in subaddress 86h	1	1	0
IGP1 is the output FIFO almost empty flag, level to be programmed in subaddress 86h	1	1	1

Table 98: I port output signal definitions; global set 84h[3:0] [1]

I port output signal definitions	Control bits D3 to D0			
	IDV1	IDV0	IDH1	IDH0
IGPH is a H gate signal, framing the scaler output	X	X	0	0
IGPH is an extended H gate (framing H gate during scaler output and scaler input H reference outside the scaler window)	X	X	0	1
IGPH is a horizontal trigger pulse, on active going edge of H gate	X	X	1	0
IGPH is a horizontal trigger pulse, on active going edge of extended H gate	X	X	1	1
IGPV is a V gate signal, framing scaled output lines	0	0	X	X
IGPV is the V reference signal from scaler input	0	1	X	X
IGPV is a vertical trigger pulse, derived from V gate	1	0	X	X
IGPV is a vertical trigger pulse derived from input V reference	1	1	X	X

[1] X = don't care.

Table 99: X port signal definitions text slicer; global set 85h[7:5] [\[1\]](#)

X port signal definitions text slicer	Control bits D7 to D5		
	ISWP1	ISWP0	ILLV
Video data limited to range 1 to 254	X	X	0
Video data limited to range 8 to 247	X	X	1
Dword byte swap, influences serial output timing D0 D1 D2 D3 ⇒ FF 00 00 SAV C _{B0} Y0 C _{R0} Y1	0	0	X
D1 D0 D3 D2 ⇒ 00 FF SAV 00 Y0 C _{B0} Y1 C _{R0}	0	1	X
D2 D3 D0 D1 ⇒ 00 SAV FF 00 C _{R0} Y1 C _{B0} Y0	1	0	X
D3 D2 D1 D0 ⇒ SAV 00 00 FF Y1 C _{R0} Y0 C _{B0}	1	1	X

[1] X = don't care.

Table 100: I port reference signal polarities; global set 85h[4:0] [\[1\]](#)

I port reference signal polarities	Control bits D4 to D0				
	IG0P	IG1P	IRVP	IRHP	IDQP
IDQ at default polarity (1 = active)	X	X	X	X	0
IDQ is inverted	X	X	X	X	1
IGPH at default polarity (1 = active)	X	X	X	0	X
IGPH is inverted	X	X	X	1	X
IGPV at default polarity (1 = active)	X	X	0	X	X
IGPV is inverted	X	X	1	X	X
IGP1 at default polarity	X	0	X	X	X
IGP1 is inverted	X	1	X	X	X
IGP0 at default polarity	0	X	X	X	X
IGP0 is inverted	1	X	X	X	X

[1] X = don't care.

Table 101: I port FIFO flag control and arbitration; global set 86h[7:4] [\[1\]](#)

Function	Control bits D7 to D4			
	VITX1	VITX0	IDG02	IDG12
See subaddress 84h: IDG11 and IDG10	X	X	X	0
	X	X	X	1
See subaddress 84h: IDG01 and IDG00	X	X	0	X
	X	X	1	X
I port signal definitions				
I port data output inhibited	0	0	X	X
Only video data is transferred	0	1	X	X
Only text data is transferred (no EAV, SAV will occur)	1	0	X	X
Text and video data is transferred, text has priority	1	1	X	X

[1] X = don't care.

Table 102: I port FIFO flag control and arbitration; global set 86h[3:0] [1]

I port FIFO flag control and arbitration	Control bits D3 to D0			
	FFL1	FFL0	FEL1	FEL0
FAE FIFO flag almost empty level				
< 16 Dwords	X	X	0	0
< 8 Dwords	X	X	0	1
< 4 Dwords	X	X	1	0
0 Dwords	X	X	1	1
FAF FIFO flag almost full level				
≥ 16 Dwords	0	0	X	X
≥ 24 Dwords	0	1	X	X
≥ 28 Dwords	1	0	X	X
32 Dwords	1	1	X	X

[1] X = don't care.

Table 103: I port I/O enable, output clock and gated clock phase control; global set 87h[7:4] [1]

Output clock and gated clock phase control	Control bits D7 to D4			
	IPCK3 [2]	IPCK2 [2]	IPCK1	IPCK0
ICLK default output phase	X	X	0	0
ICLK phase shifted by 1/2 clock cycle ⇒ recommended for ICKS1 = 1 and ICKS0 = 0 (subaddress 80h)	X	X	0	1
ICLK phase shifted by approximately 3 ns	X	X	1	0
ICLK phase shifted by 1/2 clock cycle + approximately 3 ns ⇒ alternatively to setting '01'	X	X	1	1
IDQ = gated clock default output phase	0	0	X	X
IDQ = gated clock phase shifted by 1/2 clock cycle ⇒ recommended for gated clock output	0	1	X	X
IDQ = gated clock phase shifted by approximately 3 ns	1	0	X	X
IDQ = gated clock phase shifted by 1/2 clock cycle + approximately 3 ns ⇒ alternatively to setting '01'	1	1	X	X

[1] X = don't care.

[2] IPCK3 and IPCK2 only affects the gated clock (subaddress 80h, bit ICKS2 = 1).

Table 104: I port I/O enable, output clock and gated clock phase control; global set 87h[1:0]

I port I/O enable	Control bits D1 and D0	
	IPE1	IPE0
I port output is disabled by software	0	0
I port output is enabled by software	0	1
I port output is enabled by pin ITRI at logic 0	1	0
I port output is enabled by pin ITRI at logic 1	1	1

10.7.3 Subaddress 88h

Table 105: ADC port control; global set 88h[7:4] [1]

ADC port output control/start-up control	Control bits D7 to D4			
	DOSL1	DOSL0	SWRST [2]	DPROG
DPROG = 0 after reset	X	X	X	0
DPROG = 1 can be used to assign that the device has been programmed; this bit can be monitored in the scalers status byte, bit PRDON; if DPROG was set to logic 1 and PRDON status bit shows a logic 0 a power-up or start-up fail has occurred	X	X	X	1
Scaler path is reset to its idle state, software reset	X	X	0	X
Scaler is switched back to operation	X	X	1	X
Digitized ADC1 signal is fed to port ADP[8:0]	0	0	X	X
Digitized ADC2 signal is fed to port ADP[8:0]	0	1	X	X
Digitized ADC3 signal is fed to port ADP[8:0]	1	0	X	X
Digitized ADC4 signal is fed to port ADP[8:0]	1	1	X	X

[1] X = don't care.

[2] Bit SWRST is now located here.

Table 106: Power save control; global set 88h[3] and 88h[1:0] [1]

Power save control	Control bits D3, D1 and D0		
	SLM3	SLM1	SLM0
Decoder and VBI slicer are in operational mode	X	X	0
Decoder and VBI slicer are in Power-down mode; scaler only operates, if scaler input and ICLK source is the X port (refer to subaddresses 80h and 91h/C1h)	X	X	1
Scaler is in operational mode	X	0	X
Scaler is in Power-down mode; scaler in power-down stops I port output	X	1	X
Audio clock generation active	0	X	X
Audio clock generation in power-down and output disabled	1	X	X

[1] X = don't care.

10.7.4 Subaddress 8Fh

Table 107: Status information scaler part; 8Fh[7:0]; read only register

Bit	I ² C-bus status bit	Function [1]
D7	XTRI	status on input pin XTRI, if not used for 3-state control, usable as hardware flag for software use
D6	ITRI	status on input pin ITRI, if not used for 3-state control, usable as hardware flag for software use
D5	FFIL	status of the internal 'FIFO almost filled' flag
D4	FFOV	status of the internal 'FIFO overflow' flag
D3	PRDON	copy of bit DPROG, can be used to detect power-up and start-up fails

Table 107: Status information scaler part; 8Fh[7:0]; read only register...continued

Bit	I ² C-bus status bit	Function [1]
D2	ERROF	error flag of scalers output formatter, normally set, if the output processing needs to be interrupted, due to input/output data rate conflicts, e.g. if output data rate is much too low and all internal FIFO capacity used
D1	FIDSCI	status of the field sequence ID at the scalers input
D0	FIDSCO	status of the field sequence ID at the scalers output, scaler processing dependent

[1] Status information is unsynchronized and shows the actual status at the time of I²C-bus read.

10.7.5 Subaddresses 90h and C0h

Table 108: Task handling control; register set A [90h[7:6]] and B [C0h[7:6]] [1]

Event handler control	Control bits D7 and D6	
	CONLH	OFIDC
Output field ID is field ID from scaler input	X	0
Output field ID is task status flag, which changes every time a selected task is activated (not synchronized to input field ID)	X	1
Scaler SAV/EAV byte bit D7 and task flag = 1, default	0	X
Scaler SAV/EAV byte bit D7 and task flag = 0	1	X

[1] X = don't care.

Table 109: Task handling control; register set A [90h[5:3]] and B [C0h[5:3]]

Event handler control	Control bits D5 to D3		
	FSKP2	FSKP1	FSKP0
Active task is carried out directly	0	0	0
1 field is skipped before active task is carried out	0	0	1
... fields are skipped before active task is carried out
6 fields are skipped before active task is carried out	1	1	0
7 fields are skipped before active task is carried out	1	1	1

Table 110: Task handling control; register set A [90h[2:0]] and B [C0h[2:0]] [1]

Event handler control	Control bits D2 to D0		
	RPTSK	STRC1	STRC0
Event handler triggers immediately after finishing a task	X	0	0
Event handler triggers with next V-sync	X	0	1
Event handler triggers with field ID = 0	X	1	0
Event handler triggers with field ID = 1	X	1	1
If active task is finished, handling is taken over by the next task	0	X	X
Active task is repeated once, before handling is taken over by the next task	1	X	X

[1] X = don't care.

10.7.6 Subaddresses 91h to 93h

Table 111: X port formats and configuration; register set A [91h[7:3]] and B [C1h[7:3]] [1]

Scaler input format and configuration source selection	Control bits D7 to D3				
	CONLV	HLDFV	SCSRC1	SCSRC0	SCRQE
Only if XRQT[83h[2]] = 1: scaler input source reacts on SAF7118 request	X	X	X	X	0
Scaler input source is a continuous data stream, which cannot be interrupted (must be logic 1, if SAF7118 decoder part is source of scaler or XRQT[83h[2]] = 0)	X	X	X	X	1
Scaler input source is data from decoder, data type is provided according to Table 15	X	X	0	0	X
Scaler input source is Y-C _B -C _R data from X port	X	X	0	1	X
Scaler input source is raw digital CVBS from selected analog channel, for backward compatibility only, further use is not recommended	X	X	1	0	X
Scaler input source is raw digital CVBS (or 16-bit Y + C _B -C _R , if no 16-bit outputs are active) from X port	X	X	1	1	X
SAV/EAV code bits D6 and D5 (F and V) may change between SAV and EAV	X	0	X	X	X
SAV/EAV code bits D6 and D5 (F and V) are synchronized to scalers output line start	X	1	X	X	X
SAV/EAV code bit D5 (V) and V gate on pin IGPV as generated by the internal processing; see Figure 45	0	X	X	X	X
SAV/EAV code bit D5 (V) and V gate are inverted	1	X	X	X	X

[1] X = don't care.

Table 112: X port formats and configuration; register set A [91h[2:0]] and B [C1h[2:0]] [1]

Scaler input format and configuration format control	Control bits D2 to D0		
	FSC2 [2]	FSC1 [2]	FSC0
Input is Y-C _B -C _R 4 : 2 : 2 like sampling scheme	X	X	0
Input is Y-C _B -C _R 4 : 1 : 1 like sampling scheme	X	X	1
Chroma is provided every line, default	0	0	X
Chroma is provided every 2nd line	0	1	X
Chroma is provided every 3rd line	1	0	X
Chroma is provided every 4th line	1	1	X

[1] X = don't care.

[2] FSC2 and FSC1 only to be used, if X port input source does not provide chroma information for every input line. X port input stream must contain dummy chroma bytes.

Table 113: X port input reference signal definitions; register set A [92h[7:4]] and B [C2h[7:4]] [1]

X port input reference signal definitions	Control bits D7 to D4			
	XFDV	XFDH	XDV1	XDV0
Rising edge of XRV input and decoder V123 is vertical reference	X	X	X	0
Falling edge of XRV input and decoder V123 is vertical reference	X	X	X	1
XRV is a V-sync or V gate signal	X	X	0	X

Table 113: X port input reference signal definitions; register set A [92h[7:4]] and B [C2h[7:4]] [1]...continued

X port input reference signal definitions	Control bits D7 to D4			
	XFDV	XFDH	XDV1	XDV0
XRV is a frame sync, V pulses are generated internally on both edges of FS input	X	X	1	X
X port field ID is state of XRH at reference edge on XRV (defined by XFDV)	X	0	X	X
Field ID (decoder and X port field ID) is inverted	X	1	X	X
Reference edge for field detection is falling edge of XRV	0	X	X	X
Reference edge for field detection is rising edge of XRV	1	X	X	X

[1] X = don't care.

Table 114: X port input reference signal definitions; register set A [92h[3:0]] and B [C2h[3:0]] [1]

X port input reference signal definitions	Control bits D3 to D0			
	XCODE	XDH	XDQ	XCKS
XCLK input clock and XDQ input qualifier are needed	X	X	X	0
Data rate is defined by XCLK only, no XDQ signal used	X	X	X	1
Data are qualified at XDQ input at logic 1	X	X	0	X
Data are qualified at XDQ input at logic 0	X	X	1	X
Rising edge of XRH input is horizontal reference	X	0	X	X
Falling edge of XRH input is horizontal reference	X	1	X	X
Reference signals are taken from XRH and XRV	0	X	X	X
Reference signals are decoded from EAV and SAV	1	X	X	X

[1] X = don't care.

Table 115: I port output format and configuration; register set A [93h[7:5]] and B [C3h[7:5]] [1]

I port output formats and configuration	Control bits D7 to D5		
	ICODE	I8_16	FYSK
All lines will be output	X	X	0
Skip the number of leading Y only lines, as defined by FOI1 and FOI0	X	X	1
Dwords are transferred byte wise, see subaddress 85h bits ISWP1 and ISWP0	X	0	X
Dwords are transferred 16-bit word wise via IPD and HPD, see subaddress 85h bits ISWP1 and ISWP0	X	1	X
No ITU 656 like SAV/EAV codes are available	0	X	X
ITU 656 like SAV/EAV codes are inserted in the output data stream, framed by a qualifier	1	X	X

[1] X = don't care.

Table 116: I port output format and configuration; register set A [93h[4:0]] and B [C3h[4:0]] [1]

I port output formats and configuration	Control bits D4 to D0				
	FOI1	FOI0	FSI2	FSI1	FSI0
4 : 2 : 2 Dword formatting	X	X	0	0	0
4 : 1 : 1 Dword formatting	X	X	0	0	1
4 : 2 : 0, only every 2nd line Y + C _B -C _R output, in between Y only output	X	X	0	1	0
4 : 1 : 0, only every 4th line Y + C _B -C _R output, in between Y only output	X	X	0	1	1
Y only	X	X	1	0	0
Not defined	X	X	1	0	1
Not defined	X	X	1	1	0
Not defined	X	X	1	1	1
No leading Y only line, before 1st Y + C _B -C _R line is output	0	0	X	X	X
1 leading Y only line, before 1st Y + C _B -C _R line is output	0	1	X	X	X
2 leading Y only lines, before 1st Y + C _B -C _R line is output	1	0	X	X	X
3 leading Y only lines, before 1st Y + C _B -C _R line is output	1	1	X	X	X

[1] X = don't care.

10.7.7 Subaddresses 94h to 9Bh

Table 117: Horizontal input window start; register set A [94h[7:0]; 95h[3:0]] and B [C4h[7:0]; C5h[3:0]]

Horizontal input acquisition window definition offset in X (horizontal) direction [1]	Control bits											
	A [95h[3:0]] and B [C5h[3:0]]				A [94h[7:0]] and B [C4h[7:0]]							
	XO11	XO10	XO9	XO8	XO7	XO6	XO5	XO4	XO3	XO2	XO1	XO0
A minimum of '2' should be kept, due to a line counting mismatch	0	0	0	0	0	0	0	0	0	0	1	0
Odd offsets are changing the C _B -C _R sequence in the output stream to C _R -C _B sequence	0	0	0	0	0	0	0	0	0	0	1	1
Maximum possible pixel offset = 4095	1	1	1	1	1	1	1	1	1	1	1	1

[1] Reference for counting are luminance samples.

Table 118: Horizontal input window length; register set A [96h[7:0]; 97h[3:0]] and B [C6h[7:0]; C7h[3:0]]

Horizontal input acquisition window definition input window length in X (horizontal) direction [1]	Control bits											
	A [97h[3:0]] and B [C7h[3:0]]				A [96h[7:0]] and B [C6h[7:0]]							
	XS11	XS10	XS9	XS8	XS7	XS6	XS5	XS4	XS3	XS2	XS1	XS0
No output	0	0	0	0	0	0	0	0	0	0	0	0
Odd lengths are allowed, but will be rounded up to even lengths	0	0	0	0	0	0	0	0	0	0	0	1
Maximum possible number of input pixels = 4095	1	1	1	1	1	1	1	1	1	1	1	1

[1] Reference for counting are luminance samples.

Table 119: Vertical input window start; register set A [98h[7:0]; 99h[3:0]] and B [C8h[7:0]; C9h[3:0]]

Vertical input acquisition window definition offset in Y (vertical) direction [1]	Control bits											
	A [99h[3:0]] and B [C9h[3:0]]				A [98h[7:0]] and B [C8h[7:0]]							
	YO11	YO10	YO9	YO8	YO7	YO6	YO5	YO4	YO3	YO2	YO1	YO0
Line offset = 0	0	0	0	0	0	0	0	0	0	0	0	0
Line offset = 1	0	0	0	0	0	0	0	0	0	0	0	1
Maximum line offset = 4095	1	1	1	1	1	1	1	1	1	1	1	1

[1] For trigger condition: STRC[1:0] 90h[1:0] = 00; YO + YS > (number of input lines per field – 2), will result in field dropping. Other trigger conditions: YO > (number of input lines per field – 2), will result in field dropping.

Table 120: Vertical input window length; register set A [9Ah[7:0]; 9Bh[3:0]] and B [CAh[7:0]; CBh[3:0]]

Vertical input acquisition window definition input window length in Y (vertical) direction [1]	Control bits											
	A [9Bh[3:0]] and B [CBh[3:0]]				A [9Ah[7:0]] and B [CAh[7:0]]							
	YS11	YS10	YS9	YS8	YS7	YS6	YS5	YS4	YS3	YS2	YS1	YS0
No input lines	0	0	0	0	0	0	0	0	0	0	0	0
1 input line	0	0	0	0	0	0	0	0	0	0	0	1
Maximum possible number of input lines = 4095	1	1	1	1	1	1	1	1	1	1	1	1

[1] For trigger condition: STRC[1:0] 90h[1:0] = 00; YO + YS > (number of input lines per field – 2), will result in field dropping. Other trigger conditions: YS > (number of input lines per field – 2), will result in field dropping.

10.7.8 Subaddresses 9Ch to 9Fh

Table 121: Horizontal output window length; register set A [9Ch[7:0]; 9Dh[3:0]] and B [CCh[7:0]; CDh[3:0]]

Horizontal output acquisition window definition number of desired output pixels in X (horizontal) direction [1]	Control bits											
	A [9Dh[3:0]] and B [CDh[3:0]]				A [9Ch[7:0]] and B [CCh[7:0]]							
	XD11	XD10	XD9	XD8	XD7	XD6	XD5	XD4	XD3	XD2	XD1	XD0
No output	0	0	0	0	0	0	0	0	0	0	0	0
Odd lengths are allowed, but will be filled up to even lengths	0	0	0	0	0	0	0	0	0	0	0	1
Maximum possible number of input pixels = 4095 [2]	1	1	1	1	1	1	1	1	1	1	1	1

[1] Reference for counting are luminance samples.

[2] If the desired output length is greater than the number of scaled output pixels, the last scaled pixel is repeated.

Table 122: Vertical output window length; register set A [9Eh[7:0]; 9Fh[3:0]] and B [CEh[7:0]; CFh[3:0]]

Vertical output acquisition window definition number of desired output lines in Y (vertical) direction	Control bits											
	A [9Fh[3:0]] and B [CFh[3:0]]				A [9Eh[7:0]] and B [CEh[7:0]]							
	YD11	YD10	YD9	YD8	YD7	YD6	YD5	YD4	YD3	YD2	YD1	YD0
No output	0	0	0	0	0	0	0	0	0	0	0	0
1 pixel	0	0	0	0	0	0	0	0	0	0	0	1
Maximum possible number of output lines = 4095 [1]	1	1	1	1	1	1	1	1	1	1	1	1

[1] If the desired output length is greater than the number of scaled output lines, the processing is cut.

10.7.9 Subaddresses A0h to A2h

Table 123: Horizontal prescaling; register set A [A0h[5:0]] and B [D0h[5:0]]

Horizontal integer prescaling ratio (XPSC)	Control bits D5 to D0					
	XPSC5	XPSC4	XPSC3	XPSC2	XPSC1	XPSC0
Not allowed	0	0	0	0	0	0
Downscale = 1	0	0	0	0	0	1
Downscale = 1/2	0	0	0	0	1	0
...
Downscale = 1/63	1	1	1	1	1	1

Table 124: Accumulation length; register set A [A1h[5:0]] and B [D1h[5:0]]

Horizontal prescaler accumulation sequence length (XACL)	Control bits D5 to D0					
	XACL5	XACL4	XACL3	XACL2	XACL1	XACL0
Accumulation length = 1	0	0	0	0	0	0
Accumulation length = 2	0	0	0	0	0	1
...
Accumulation length = 64	1	1	1	1	1	1

Table 125: Prescaler DC gain and FIR prefilter control; register set A [A2h[7:4]] and B [D2h[7:4]] [1]

FIR prefilter control	Control bits D7 to D4			
	PFUV1	PFUV0	PFY1	PFY0
Luminance FIR filter bypassed	X	X	0	0
$H_y(z) = \frac{1}{4} (1 \ 2 \ 1)$	X	X	0	1
$H_y(z) = \frac{1}{8} (-1 \ 1 \ 1.75 \ 4.5 \ 1.75 \ 1 \ -1)$	X	X	1	0
$H_y(z) = \frac{1}{8} (1 \ 2 \ 2 \ 2 \ 1)$	X	X	1	1
Chrominance FIR filter bypassed	0	0	X	X
$H_{uv}(z) = \frac{1}{4} (1 \ 2 \ 1)$	0	1	X	X
$H_{uv}(z) = \frac{1}{32} (3 \ 8 \ 10 \ 8 \ 3)$	1	0	X	X
$H_{uv}(z) = \frac{1}{8} (1 \ 2 \ 2 \ 2 \ 1)$	1	1	X	X

[1] X = don't care.

Table 126: Prescaler DC gain and FIR prefilter control; register set A [A2h[3:0]] and B [D2h[3:0]] [1]

Prescaler DC gain	Control bits D3 to D0			
	XC2_1	XDCG2	XDCG1	XDCG0
Prescaler output is renormalized by gain factor = 1	X	0	0	0
Prescaler output is renormalized by gain factor = $\frac{1}{2}$	X	0	0	1
Prescaler output is renormalized by gain factor = $\frac{1}{4}$	X	0	1	0
Prescaler output is renormalized by gain factor = $\frac{1}{8}$	X	0	1	1
Prescaler output is renormalized by gain factor = $\frac{1}{16}$	X	1	0	0
Prescaler output is renormalized by gain factor = $\frac{1}{32}$	X	1	0	1
Prescaler output is renormalized by gain factor = $\frac{1}{64}$	X	1	1	0
Prescaler output is renormalized by gain factor = $\frac{1}{128}$	X	1	1	1
Weighting of all accumulated samples is factor '1'; e.g. XACL = 4 \Rightarrow sequence 1 + 1 + 1 + 1 + 1	0	X	X	X
Weighting of samples inside sequence is factor '2'; e.g. XACL = 4 \Rightarrow sequence 1 + 2 + 2 + 2 + 1	1	X	X	X

[1] X = don't care.

10.7.10 Subaddresses A4h to A6h

Table 127: Luminance brightness control; register set A [A4h[7:0]] and B [D4h[7:0]]

Luminance brightness control	Control bits D7 to D0							
	BRIG7	BRIG6	BRIG5	BRIG4	BRIG3	BRIG2	BRIG1	BRIG0
Value = 0	0	0	0	0	0	0	0	0
Nominal value = 128	1	0	0	0	0	0	0	0
Value = 255	1	1	1	1	1	1	1	1

Table 128: Luminance contrast control; register set A [A5h[7:0]] and B [D5h[7:0]]

Luminance contrast control	Control bits D7 to D0							
	CONT7	CONT6	CONT5	CONT4	CONT3	CONT2	CONT1	CONT0
Gain = 0	0	0	0	0	0	0	0	0
Gain = $\frac{1}{64}$	0	0	0	0	0	0	0	1
Nominal gain = 64	0	1	0	0	0	0	0	0
Gain = $\frac{127}{64}$	0	1	1	1	1	1	1	1

Table 129: Chrominance saturation control; register set A [A6h[7:0]] and B [D6h[7:0]]

Chrominance saturation control	Control bits D7 to D0							
	SATN7	SATN6	SATN5	SATN4	SATN3	SATN2	SATN1	SATN0
Gain = 0	0	0	0	0	0	0	0	0
Gain = $\frac{1}{64}$	0	0	0	0	0	0	0	1
Nominal gain = 64	0	1	0	0	0	0	0	0
Gain = $\frac{127}{64}$	0	1	1	1	1	1	1	1

10.7.11 Subaddresses A8h to AEh

Table 130: Horizontal luminance scaling increment; register set A [A8h[7:0]; A9h[7:0]] and B [D8h[7:0]; D9h[7:0]]

Horizontal luminance scaling increment	Control bits			
	A [A9h[7:4]] B [D9h[7:4]]	A [A9h[3:0]] B [D9h[3:0]]	A [A8h[7:4]] B [D8h[7:4]]	A [A8h[3:0]] B [D8h[3:0]]
	XSCY[15:12] [1]	XSCY[11:8]	XSCY[7:4]	XSCY[3:0]
Scale = $1024/1$ (theoretical) zoom	0000	0000	0000	0000
Scale = $1024/294$, lower limit defined by data path structure	0000	0001	0010	0110
Scale = $1024/1023$ zoom	0000	0011	1111	1111
Scale = 1, equals 1024	0000	0100	0000	0000
Scale = $1024/1025$ downscale	0000	0100	0000	0001
Scale = $1024/8191$ downscale	0001	1111	1111	1111

[1] Bits XSCY[15:13] are reserved and are set to logic 0.

Table 131: Horizontal luminance phase offset; register set A [AAh[7:0]] and B [DAh[7:0]]

Horizontal luminance phase offset	Control bits D7 to D0							
	XPHY7	XPHY6	XPHY5	XPHY4	XPHY3	XPHY2	XPHY1	XPHY0
Offset = 0	0	0	0	0	0	0	0	0
Offset = $1/32$ pixel	0	0	0	0	0	0	0	1
Offset = $32/32 = 1$ pixel	0	0	1	0	0	0	0	0
Offset = $255/32$ pixel	1	1	1	1	1	1	1	1

Table 132: Horizontal chrominance scaling increment; register set A [ACh[7:0]; ADh[7:0]] and B [DCh[7:0]; DDh[7:0]]

Horizontal chrominance scaling increment	Control bits			
	A [ADh[7:4]] B [DDh[7:4]]	A [ADh[3:0]] B [DDh[3:0]]	A [ACh[7:4]] B [DCh[7:4]]	A [ACh[3:0]] B [DCh[3:0]]
	XSCC[15:12] [1]	XSCC[11:8]	XSCC[7:4]	XSCC[3:0]
This value must be set to the luminance value $1/2 \times XSCY[15:0]$	0000	0000	0000	0000
	0000	0000	0000	0001
	0001	1111	1111	1111

[1] Bits XSCC[15:13] are reserved and are set to logic 0.

Table 133: Horizontal chrominance phase offset; register set A [AEh[7:0]] and B [DEh[7:0]]

Horizontal chrominance phase offset	Control bits D7 to D0							
	XPHC7	XPHC6	XPHC5	XPHC4	XPHC3	XPHC2	XPHC1	XPHC0
This value must be set to $1/2 \times XPHY[7:0]$	0	0	0	0	0	0	0	0
	0	0	0	0	0	0	0	1
	1	1	1	1	1	1	1	1

10.7.12 Subaddresses B0h to BFh

Table 134: Vertical luminance scaling increment; register set A [B0h[7:0]; B1h[7:0]] and B [E0h[7:0]; E1h[7:0]]

Vertical luminance scaling increment	Control bits			
	A [B1h[7:4]] B [E1h[7:4]]	A [B1h[3:0]] B [E1h[3:0]]	A [B0h[7:4]] B [E0h[7:4]]	A [B0h[3:0]] B [E0h[3:0]]
	ySCY[15:12]	ySCY[11:8]	ySCY[7:4]	ySCY[3:0]
Scale = $1024/1$ (theoretical) zoom	0000	0000	0000	0001
Scale = $1024/1023$ zoom	0000	0011	1111	1111
Scale = 1, equals 1024	0000	0100	0000	0000
Scale = $1024/1025$ downscale	0000	0100	0000	0001
Scale = $1/63.999$ downscale	1111	1111	1111	1111

Table 135: Vertical chrominance scaling increment; register set A [B2h[7:0]; B3h[7:0]] and B [E2h[7:0]; E3h[7:0]]

Vertical chrominance scaling increment	Control bits			
	A [B3h[7:4]] B [E3h[7:4]]	A [B3h[3:0]] B [E3h[3:0]]	A [B2h[7:4]] B [E2h[7:4]]	A [B2h[3:0]] B [E2h[3:0]]
	ySCc[15:12]	ySCc[11:8]	ySCc[7:4]	ySCc[3:0]
This value must be set to the luminance value YSCY[15:0]	0000	0000	0000	0001
	1111	1111	1111	1111

Table 136: Vertical scaling mode control; register set A [B4h[4 and 0]] and B [E4h[4 and 0]] [1]

Vertical scaling mode control	Control bits D4 and D0	
	YMIR	YMODE
Vertical scaling performs linear interpolation between lines	X	0
Vertical scaling performs higher order accumulating interpolation, better alias suppression	X	1
No mirroring	0	X
Lines are mirrored	1	X

[1] X = don't care.

Table 137: Vertical chrominance phase offset '00'; register set A [B8h[7:0]] and B [E8h[7:0]]

Vertical chrominance phase offset	Control bits D7 to D0							
	YPC07	YPC06	YPC05	YPC04	YPC03	YPC02	YPC01	YPC00
Offset = 0	0	0	0	0	0	0	0	0
Offset = $32/32 = 1$ line	0	0	1	0	0	0	0	0
Offset = $255/32$ lines	1	1	1	1	1	1	1	1

Table 138: Vertical luminance phase offset '00'; register set A [BCh[7:0]] and B [ECh[7:0]]

Vertical luminance phase offset	Control bits D7 to D0							
	YPY07	YPY06	YPY05	YPY04	YPY03	YPY02	YPY01	YPY00
Offset = 0	0	0	0	0	0	0	0	0
Offset = $\frac{32}{32} = 1$ line	0	0	1	0	0	0	0	0
Offset = $\frac{255}{32}$ lines	1	1	1	1	1	1	1	1

11. Programming start setup

11.1 Decoder part

The given values force the following behavior of the SAF7118 decoder part:

- The analog input AI11 expects an NTSC M, PAL B, D, G, H and I or SECAM signal in CVBS format; analog anti-alias filter and AGC active
- Automatic field detection enabled
- Standard ITU 656 output format enabled on expansion (X) port
- Contrast, brightness and saturation control in accordance with ITU standards
- Adaptive comb filter for luminance and chrominance activated
- Pins LLC, LLC2, XTOUT, RTS0, RTS1 and RTCO are set to 3-state

Table 139: Decoder part start setup values for the three main standards

Subaddress (hexadecimal)	Register function	Bit name [1]	Values (hexadecimal)		
			NTSC M	PAL B, D, G, H and I	SECAM
00	chip version	ID7 to ID4	read only		
01	increment delay	X, WPOFF, GUDL1, GUDL0 and IDEL3 to IDEL0	47	47	47
02	analog input control 1	FUSE1, FUSE0 and MODE5 to MODE0	C0	C0	C0
03	analog input control 2	X, HLNRS, VBSL, CPOFF, HOLDG, GAFIX, GAI28 and GAI18	10	10	10
04	analog input control 3	GAI17 to GAI10	90	90	90
05	analog input control 4	GAI27 to GAI20	90	90	90
06	horizontal sync start	HSB7 to HSB0	EB	EB	EB
07	horizontal sync stop	HSS7 to HSS0	E0	E0	E0
08	sync control	AUFD, FSEL, FOET, HTC1, HTC0, HPLL, VNOI1 and VNOI0	98	98	98
09	luminance control	BYPS, YCOMB, LDEL, LUBW and LUF13 to LUF10	40	40	1B
0A	luminance brightness control	DBRI7 to DBRI0	80	80	80
0B	luminance contrast control	DCON7 to DCON0	44	44	44
0C	chrominance saturation control	DSAT7 to DSAT0	40	40	40
0D	chrominance hue control	HUEC7 to HUEC0	00	00	00
0E	chrominance control 1	CDTO, CSTD2 to CSTD0, DCVF, FCTC, AUTO0 and CCOMB	89	81	D0

Table 139: Decoder part start setup values for the three main standards...continued

Subaddress (hexadecimal)	Register function	Bit name [1]	Values (hexadecimal)		
			NTSC M	PAL B, D, G, H and I	SECAM
0F	chrominance gain control	ACGC and CGAIN6 to CGAIN0	2A	2A	80
10	chrominance control 2	OFFU1, OFFU0, OFFV1, OFFV0, CHBW and LCBW2 to LCBW0	0E	06	00
11	mode/delay control	COLO, RTP1, HDEL1, HDEL0, RTP0 and YDEL2 to YDEL0	00	00	00
12	RT signal control	RTSE13 to RTSE10 and RTSE03 to RTSE00	00	00	00
13	RT/X port output control	RTCE, XRHS, XRVS1, XRVS0, HLSEL and OFTS2 to OFTS0	00	00	00
14	analog/ADC/compatibility control	CM99, UPTCV, AOSL1, AOSL0, XTOUTE, AUTO1, APCK1 and APCK0	00	00	00
15	VGATE start, FID change	VSTA7 to VSTA0	11	11	11
16	VGATE stop	VSTO7 to VSTO0	FE	FE	FE
17	miscellaneous, VGATE configuration and MSBs	LLCE, LLC2E, LATY2 to LATY0, VGPS, VSTO8 and VSTA8	C0	C0	C0
18	raw data gain control	RAWG7 to RAWG0	40	40	40
19	raw data offset control	RAWO7 to RAWO0	80	80	80
1A to 1D	reserved	X, X, X, X, X, X, X, X	00	00	00
1E	status byte 1 video decoder	-, HLCK, SLTCA, GLIMT, GLIMB, WIPA, DCSTD1 and DCSTD0	read only		
1F	status byte 2 video decoder	INTL, HVLN, FIDT, -, TYPE3, COLSTR, COPRO and RDCAP	read only		

[1] All X values must be set to logic 0.

11.2 Component video part and interrupt mask

The given values force the following behavior of the SAF7118 component video part:

- The analog inputs AI11, AI21, AI31 and AI41 expect an RGBS signal; analog anti-alias filters and AGC for the sync channel active
- For other settings see decoder part ([Section 11.1](#))

Table 140: Component video part and interrupt mask start setup values

Subaddress (hexadecimal)	Register function	Bit name [1]	Values (hexadecimal)
23	analog input control 5	AOSL2, ADPE, EXCLK, REFA, X, EXMCE, GAI48 and GAI38	00
24	analog input control 6	GAI37 to GAI30	90
25	analog input control 7	GAI47 to GAI40	90
26 to 28	reserved	X, X, X, X, X, X, X, X	00
29	component delay	FSWE, FSWI, FSWDL1, FSWDL0, CMFI, CPDL2 to CPDL0	40
2A	component brightness control	CBRI7 to CBRI0	80

Table 140: Component video part and interrupt mask start setup values...continued

Subaddress (hexadecimal)	Register function	Bit name [1]	Values (hexadecimal)
2B	component contrast control	CCON7 to CCON0	40
2C	component saturation control	CSAT7 to CSAT0	47
2D	interrupt mask 1	X, X, X, MVPSV, MPPV, MCCV, X and MERROF	00
2E	interrupt mask 2	X, MHLCK, X, X, X, X, MDCSTD1 and MDCSTD0	00
2F	interrupt mask 3	MINTL, MHLVLN, MFIDT, X, MTYPE3, MCOLSTR, MCOPRO and MRDCAP	00

[1] All X values must be set to logic 0.

11.3 Audio clock generation part

The given values force the following behavior of the SAF7118 audio clock generation part:

- Used crystal is 24.576 MHz
- Expected field frequency is 59.94 Hz (e.g. NTSC M standard)
- Generated audio master clock frequency at pin AMCLK is $256 \text{ kHz} \times 44.1 \text{ kHz} = 11.2896 \text{ MHz}$
- AMCLK is externally connected to AMXCLK [short-cut between pins P11 (72) and M12 (76)]
- ASCLK = $32 \text{ kHz} \times 44.1 \text{ kHz} = 1.4112 \text{ MHz}$
- ALRCLK is 44.1 kHz

Table 141: Audio clock part setup values

Subaddress (hexadecimal)	Register function	Bit name [1]	Values (binary)								Start (hexadecimal)
			7	6	5	4	3	2	1	0	
30	audio master clock cycles per field; bits D7 to D0	ACPF7 to ACPF0	1	0	1	1	1	1	0	0	BC
31	audio master clock cycles per field; bits D15 to D8	ACPF15 to ACPF8	1	1	0	1	1	1	1	1	DF
32	audio master clock cycles per field; bits D17 and D16	X, X, X, X, X, X, ACPF17 and ACPF16	0	0	0	0	0	0	1	0	02
33	reserved	X, X, X, X, X, X, X, X	0	0	0	0	0	0	0	0	00
34	audio master clock nominal increment; bits D7 to D0	ACNI7 to ACNI0	1	1	0	0	1	1	0	1	CD
35	audio master clock nominal increment; bits D15 to D8	ACNI15 to ACNI8	1	1	0	0	1	1	0	0	CC
36	audio master clock nominal increment; bits D21 to D16	X, X, ACNI21 to ACNI16	0	0	1	1	1	0	1	0	3A
37	reserved	X, X, X, X, X, X, X, X	0	0	0	0	0	0	0	0	00
38	clock ratio AMXCLK to ASCLK	X, X, SDIV5 to SDIV0	0	0	0	0	0	0	1	1	03
39	clock ratio ASCLK to ALRCLK	X, X, LRDIV5 to LRDIV0	0	0	0	1	0	0	0	0	10
3A	audio clock generator basic setup	X, X, X, X, APLL, AMVR, LRPH, SCPH	0	0	0	0	0	0	0	0	00
3B to 3F	reserved	X, X, X, X, X, X, X, X	0	0	0	0	0	0	0	0	00

[1] All X values must be set to logic 0.

11.4 Data slicer and data type control part

The given values force the following behavior of the SAF7118 VBI data slicer part:

- Closed captioning data are expected at line 21 of field 1 (60 Hz/525 line system)
- All other lines are processed as active video
- Sliced data are framed by ITU 656 like SAV/EAV sequence (DID[5:0] = 3Eh ⇒ MSB of SAV/EAV = 1)

Table 142: Data slicer start setup values

Subaddress (hexadecimal)	Register function	Bit name ^[1]	Values (binary)								Start (hexadecimal)	
			7	6	5	4	3	2	1	0		
40	slicer control 1	X, HAM_N, FCE, HUNT_N, X, X, X, X	0	1	0	0	0	0	0	0	0	40
41 to 53	line control register 2 to 20	LCRn_7 to LCRn_0 (n = 2 to 20)	1	1	1	1	1	1	1	1	1	FF
54	line control register 21	LCR21_7 to LCR21_0	0	1	0	1	1	1	1	1	1	5F
55 to 57	line control register 22 to 24	LCRn_7 to LCRn_0 (n = 22 to 24)	1	1	1	1	1	1	1	1	1	FF
58	programmable framing code	FC7 to FC0	0	0	0	0	0	0	0	0	0	00
59	horizontal offset for slicer	HOFF7 to HOFF0	0	1	0	0	0	0	1	1	1	47
5A	vertical offset for slicer	VOFF7 to VOFF0	0	0	0	0	0	0	1	1	0	06 ^[2]
5B	field offset and MSBs for horizontal and vertical offset	FOFF, RECODE, X, VOFF8, X, HOFF10 to HOFF8	1	0	0	0	0	0	0	1	1	83 ^[2]
5C	reserved	X, X, X, X, X, X, X, X	0	0	0	0	0	0	0	0	0	00
5D	header and data identification code control	FVREF, X, DID5 to DID0	0	0	1	1	1	1	1	1	0	3E
5E	sliced data identification code	X, X, SDID5 to SDID0	0	0	0	0	0	0	0	0	0	00
5F	reserved	X, X, X, X, X, X, X, X	0	0	0	0	0	0	0	0	0	00
60	slicer status byte 0	-, FC8V, FC7V, VPSV, PPV, CCV, -, -	read only register									
61	slicer status byte 1	-, -, F21_N, LN8 to LN4	read only register									
62	slicer status byte 2	LN3 to LN0, DT3 to DT0	read only register									

[1] All X values must be set to logic 0.

[2] Changes for 50 Hz/625 line systems: subaddress 5Ah = 03h and subaddress 5Bh = 03h.

11.5 Scaler and interfaces

[Table 143](#) shows some examples for the scaler programming with:

- prsc = prescale ratio
- fisc = fine scale ratio
- vsc = vertical scale ratio

The ratio is defined as: $\frac{\text{number of input pixel}}{\text{number of output pixel}}$

In the following settings the VBI data slicer is inactive. To activate the VBI data slicer, VITX[1:0] 86h[7:6] has to be set to '11'. Depending on the VBI data slicer settings, the sliced VBI data is inserted after the end of the scaled video lines, if the regions of VBI data slicer and scaler overlaps.

To compensate the running-in of the vertical scaler, the vertical input window lengths are extended by 2 lines to 290 lines, respectively 242 lines for XS, but the scaler increment calculations are done with 288 lines, respectively 240 lines.

11.5.1 Trigger condition

For trigger condition STRC[1:0] 90h[1:0] not equal to '00'.

If the value of (YO + YS) is greater than or equal to 262 (NTSC), respectively 312 (PAL) the output field rate is reduced to 30 Hz, respectively 25 Hz.

Horizontal and vertical offsets (XO and YO) have to be used to adjust the displayed video in the display window. As this adjustment is application dependent, the listed values are only dummy values.

11.5.2 Maximum zoom factor

The maximum zoom factor is dependent on the back-end data rate and therefore back-end clock and data format dependent (8-bit or 16-bit output). The maximum horizontal zoom is limited to approximately 3.5, due to internal data path restrictions.

11.5.3 Examples

Table 143: Example of configurations

Example number	Scaler source and reference events	Input window	Output window	Scale ratios
1	analog input to 8-bit I port output, with SAV/EAV codes, 8-bit serial byte stream decoder output at X port; acquisition trigger at falling edge vertical and rising edge horizontal reference signal; H and V gates on IGPH and IGPV, IGP0 = VBI sliced data flag, IGP1 = FIFO almost full, level ≥ 24, IDQ qualifier logic 1 active	720 × 240	720 × 240	prsc = 1; fisc = 1; vsc = 1
2	analog input to 16-bit output, without SAV/EAV codes, Y on I port, C _B -C _R on H port and decoder output at X port; acquisition trigger at falling edge vertical and rising edge horizontal reference signal; H and V-pulses on IGPH and IGPV, output FID on IGP0, IGP1 fixed to logic 1, IDQ qualifier logic 0 active	704 × 288	768 × 288	prsc = 1; fisc = 0.91667; vsc = 1
3	X port input 8-bit with SAV/EAV codes, no reference signals on XRH and XRV, XCLK as gated clock; field detection and acquisition trigger on different events; acquisition triggers at rising edge vertical and rising edge horizontal; I port output 8-bit with SAV/EAV codes like example number 1	720 × 240	352 × 288	prsc = 2; fisc = 1.022; vsc = 0.8333
4	X port and H port for 16-bit Y-C _B -C _R 4 : 2 : 2 input (if no 16-bit output selected); XRH and XRV as references; field detection and acquisition trigger at falling edge vertical and rising edge horizontal; I port output 8-bit with SAV/EAV codes, but Y only output	720 × 288	200 × 80	prsc = 2; fisc = 1.8; vsc = 3.6

Table 144: Scaler and interface configuration example

I ² C-bus address (hex)	Main functionality	Example 1		Example 2		Example 3		Example 4	
		Hex	Dec	Hex	Dec	Hex	Dec	Hex	Dec
Global settings									
80	task enable, IDQ and back-end clock definition	10	-	10	-	10	-	10	-
83	XCLK output phase and X port output enable	01	-	01	-	00	-	00	-
84	IGPH, IGPV, IGP0 and IGP1 output definition	A0	-	C5	-	A0	-	A0	-
85	signal polarity control and I port byte swapping	10	-	09	-	10	-	10	-
86	FIFO flag thresholds and video/text arbitration	45	-	40	-	45	-	45	-
87	ICLK and IDQ output phase and I port enable	01	-	01	-	01	-	01	-
88	power save control and software reset	F0	-	F0	-	F0	-	F0	-
Task A: scaler input configuration and output format settings									
90	task handling	00	-	00	-	00	-	00	-
91	Scaler input source and format definition	08	-	08	-	18	-	38	-
92	reference signal definition at scaler input	10	-	10	-	10	-	10	-
93	I port output formats and configuration	80	-	40	-	80	-	84	-
Input and output window definition									
94	horizontal input offset (XO)	10	16	10	16	10	16	10	16
95		00	-	00	-	00	-	00	-

Table 144: Scaler and interface configuration example...continued

I ² C-bus address (hex)	Main functionality	Example 1		Example 2		Example 3		Example 4	
		Hex	Dec	Hex	Dec	Hex	Dec	Hex	Dec
96	horizontal input (source) window length (XS)	D0	720	C0	704	D0	720	D0	720
97		02	-	02	-	02	-	02	-
98	vertical input offset (YO)	0A	10	0A	10	0A	10	0A	10
99		00	-	00	-	00	-	00	-
9A	vertical input (source) window length (YS)	F2	242	22	290	F2	242	22	290
9B		00	-	01	-	00	-	01	-
9C	horizontal output (destination) window length (XD)	D0	720	00	768	60	352	C8	200
9D		02	-	03	-	01	-	00	-
9E	vertical output (destination) window length (YD)	F0	240	20	288	20	288	50	80
9F		00	-	01	-	01	-	00	-
Prefiltering and prescaling									
A0	integer prescale (value '00' not allowed)	01	-	01	-	02	-	02	-
A1	accumulation length for prescaler	00	-	00	-	02	-	03	-
A2	FIR prefilter and prescaler DC normalization	00	-	00	-	AA	-	F2	-
A4	scaler brightness control	80	128	80	128	80	128	80	128
A5	scaler contrast control	40	64	40	64	40	64	11	17
A6	scaler saturation control	40	64	40	64	40	64	11	17
Horizontal phase scaling									
A8	horizontal scaling increment for luminance	00	1024	AA	938	18	1048	34	1844
A9		04	-	03	-	04	-	07	-
AA	horizontal phase offset luminance	00	-	00	-	00	-	00	-
AC	horizontal scaling increment for chrominance	00	512	D5	469	0C	524	9A	922
AD		02	-	01	-	02	-	03	-
AE	horizontal phase offset chrominance	00	-	00	-	00	-	00	-
Vertical scaling									
B0	vertical scaling increment for luminance	00	1024	00	1024	55	853	66	3686
B1		04	-	04	-	03	-	0E	-
B2	vertical scaling increment for chrominance	00	1024	00	1024	55	853	66	3686
B3		04	-	04	-	03	-	0E	-
B4	vertical scaling mode control	00	-	00	-	00	-	01	-
B8 to BF	vertical phase offsets luminance and chrominance (need to be used for interlace correct scaled output)	start with B8 to BF at 00h, if there are no problems with the interlaced scaled output optimize according to Section 8.4.3.2							

12. Limiting values

Table 145: Limiting values

In accordance with the Absolute Maximum Rating System (IEC 60134). All ground pins connected together and grounded (0 V); all supply pins connected together.

Symbol	Parameter	Conditions	Min	Max	Unit	
V_{DD}	digital supply voltage		-0.5	+4.6	V	
V_{DDA}	analog supply voltage		-0.5	+4.6	V	
$V_{i(A)}$	input voltage at analog inputs		-0.5	+4.6	V	
$V_{i(n)}$	input voltage at pins XTALI, SDA and SCL		-0.5	$V_{DD} + 0.5$	V	
$V_{i(D)}$	input voltage at digital inputs or I/O pins	outputs in 3-state	-0.5	+4.6	V	
		outputs in 3-state	[1]	-0.5	+5.5	V
ΔV_{SS}	voltage difference between $V_{SSA(n)}$ and $V_{SSD(n)}$		-	100	mV	
T_{stg}	storage temperature		-65	+150	°C	
T_{amb}	ambient temperature		-40	+85	°C	
V_{esd}	electrostatic discharge voltage	human body model	[2]	-	±2000	V
		machine model	[3]	-	±200	V

[1] Condition for maximum voltage at digital inputs or I/O pins: $3.0\text{ V} < V_{DD} < 3.6\text{ V}$.

[2] Class 2 according to JESD22-A114-B.

[3] Class B according to EIA/JESD22-A115-A.

13. Thermal characteristics

Table 146: Thermal characteristics

Symbol	Parameter	Conditions	Value	Unit
$R_{th(j-a)}$	thermal resistance from junction to ambient			
	SAF7118EH	in free air	[1] 29	K/W
	SAF7118H	in free air	[1] 25	K/W

[1] The overall $R_{th(j-a)}$ value can vary depending on the board layout. To minimize the effective $R_{th(j-a)}$ all power and ground pins must be connected to the power and ground layers directly. An ample copper area directly under the SAF7118 with a number of through-hole plating, connected to the ground layer (four-layer board: second layer), can also reduce the effective $R_{th(j-a)}$. Please do not use any solder-stop varnish under the chip. In addition the usage of soldering glue with a high thermal conductance after curing is recommended.

14. Characteristics

Table 147: Characteristics

$V_{DDD} = 3.0\text{ V to }3.6\text{ V}$; $V_{DDA} = 3.1\text{ V to }3.5\text{ V}$; $T_{amb} = -40\text{ }^{\circ}\text{C to }+85\text{ }^{\circ}\text{C}$ (typical values measured at $T_{amb} = 25\text{ }^{\circ}\text{C}$); timings and levels refer to drawings and conditions illustrated in [Figure 89](#); unless otherwise specified.

Symbol	Parameter	Conditions	Min	Typ	Max	Unit
Supplies						
V_{DDD}	digital supply voltage		3.0	3.3	3.6	V
I_{DDD}	digital supply current	X port 3-state; 8-bit I port	-	85	-	mA
P_D	power dissipation digital part		-	280	-	mW
V_{DDA}	analog supply voltage		3.1	3.3	3.5	V
I_{DDA}	analog supply current	AOSL1 and AOSL0 = 0				
		CVBS mode	-	75	-	mA
		Y/C mode	-	130	-	mA
		component mode	-	250	-	mA
P_A	power dissipation analog part	CVBS mode	-	248	-	mW
		Y/C mode	-	430	-	mW
		component mode	-	825	-	mW
$P_{\text{tot(A+D)}}$	total power dissipation analog and digital part	CVBS mode	[1] -	533	-	mW
		Y/C mode	[1] -	710	-	mW
		component mode	[1] -	1105	1350	mW
$P_{\text{tot(A+D)(pd)}}$	total power dissipation analog and digital part in Power-down mode	CE pulled down to ground	-	5	-	mW
$P_{\text{tot(A+D)(ps)}}$	total power dissipation analog and digital part in Power-save mode	I ² C-bus controlled via subaddress 88h = 0Fh	-	75	-	mW
Analog part						
I_{clamp}	clamping current	$V_1 = 1\text{ V DC}$	-	±8	-	μA
$V_{i(p-p)}$	input voltage (peak-to-peak value)	for normal video levels 1 V (p-p), -3 dB termination 18/56 Ω and AC coupling required; coupling capacitor is 47 nF	-	0.7	-	V
$ Z_i $	input impedance	clamping current off	200	-	-	kΩ
C_i	input capacitance		-	-	10	pF
α_{cs}	channel crosstalk	$f_i < 5\text{ MHz}$	-	-	-50	dB

Table 147: Characteristics...*continued*

$V_{DD} = 3.0\text{ V to }3.6\text{ V}$; $V_{DDA} = 3.1\text{ V to }3.5\text{ V}$; $T_{amb} = -40\text{ }^{\circ}\text{C to }+85\text{ }^{\circ}\text{C}$ (typical values measured at $T_{amb} = 25\text{ }^{\circ}\text{C}$); timings and levels refer to drawings and conditions illustrated in [Figure 89](#); unless otherwise specified.

Symbol	Parameter	Conditions	Min	Typ	Max	Unit
9-bit analog-to-digital converters						
B	analog bandwidth	at -3 dB	-	7	-	MHz
ϕ_{diff}	differential phase	amplifier plus anti-alias filter bypassed	-	2	-	deg
G_{diff}	differential gain	amplifier plus anti-alias filter bypassed	-	2	-	%
$f_{clk(ADC)}$	ADC clock frequency		25.4		28.6	MHz
$LE_{dc(d)}$	DC differential linearity error		-	0.7	-	LSB
$LE_{dc(i)}$	DC integral linearity error		-	1	-	LSB
ΔG_{ADC}	ADC gain inequality	$\left(\frac{\text{maximum deviation}}{\text{minimum deviation}} - 1\right) \times 100$	[2]	3	-	%
Digital inputs						
$V_{IL(SCL,SDA)}$	LOW-level input voltage pins SDA and SCL		[3] -0.5	-	+0.3 $V_{DD(I2C)}$	V
$V_{IH(SCL,SDA)}$	HIGH-level input voltage pins SDA and SCL		[3] 0.7 $V_{DD(I2C)}$	-	$V_{DD(I2C)} + 0.5$	V
$V_{IL(XTALI)}$	LOW-level CMOS input voltage pin XTALI		-0.3	-	+0.8	V
$V_{IH(XTALI)}$	HIGH-level CMOS input voltage pin XTALI		2.0	-	$V_{DD} + 0.3$	V
$V_{IL(n)}$	LOW-level input voltage all other inputs		-0.3	-	+0.8	V
$V_{IH(n)}$	HIGH-level input voltage all other inputs		2.0	-	5.5	V
I_{LI}	input leakage current		-	-	1	μA
$I_{LI/O}$	I/O leakage current		-	-	10	μA
C_i	input capacitance	I/O at high-impedance	-	-	8	pF
Digital outputs [4]						
$V_{OL(SDA)}$	LOW-level output voltage pin SDA	SDA at 3 mA sink current	-	-	0.4	V
$V_{OL(clk)}$	LOW-level output voltage for clocks		0	-	0.6	V
$V_{OH(clk)}$	HIGH-level output voltage for clocks		2.4	-	$V_{DD} + 0.5$	V

Table 147: Characteristics...continued

$V_{DD} = 3.0\text{ V to }3.6\text{ V}$; $V_{DDA} = 3.1\text{ V to }3.5\text{ V}$; $T_{amb} = -40\text{ }^{\circ}\text{C to }+85\text{ }^{\circ}\text{C}$ (typical values measured at $T_{amb} = 25\text{ }^{\circ}\text{C}$); timings and levels refer to drawings and conditions illustrated in [Figure 89](#); unless otherwise specified.

Symbol	Parameter	Conditions	Min	Typ	Max	Unit
$V_{OL(n)}$	LOW-level output voltage all other digital outputs		0	-	0.4	V
$V_{OH(n)}$	HIGH-level output voltage all other digital outputs		2.4	-	$V_{DD} + 0.5$	V

Clock output timing (LLC and LLC2) [5]

C_L	output load capacitance		15	-	50	pF
T_{cy}	cycle time	pin LLC	35	-	39	ns
		pin LLC2	70	-	78	ns
δ	duty factors for t_{LLCH}/t_{LLC} and t_{LLC2H}/t_{LLC2}	$C_L = 40\text{ pF}$	40	-	60	%
t_r	rise time LLC and LLC2	$0.2\text{ V to }V_{DD} - 0.2\text{ V}$	-	-	5	ns
t_f	fall time LLC and LLC2	$V_{DD} - 0.2\text{ V to }0.2\text{ V}$	-	-	5	ns
$t_{d(LLC-LLC2)}$	delay time between LLC and LLC2 output	measured at 1.5 V ; $C_L = 25\text{ pF}$	-4	-	+8	ns

Horizontal PLL

$f_{hor(nom)}$	nominal line frequency	50 Hz field	-	15625	-	Hz
		60 Hz field	-	15734	-	Hz
$\Delta f_{hor}/f_{hor(nom)}$	permissible static deviation		-	-	5.7	%

Subcarrier PLL

$f_{sc(nom)}$	nominal subcarrier frequency	PAL BGHI	-	4433619	-	Hz
		NTSC M	-	3579545	-	Hz
		PAL M	-	3575612	-	Hz
		PAL N	-	3582056	-	Hz
Δf_{sc}	lock-in range		± 400	-		Hz

Crystal oscillator for 32.11 MHz [6]

$f_{xtal(nom)}$	nominal frequency		-	32.11	-	MHz
$\Delta f_{xtal(nom)}$	permissible nominal frequency deviation		-	-	$\pm 70 \times 10^{-6}$	
$\Delta f_{xtal(nom)(T)}$	permissible nominal frequency deviation with temperature		-	-	$\pm 30 \times 10^{-6}$	

Table 147: Characteristics...*continued*

$V_{DD} = 3.0\text{ V to }3.6\text{ V}$; $V_{DDA} = 3.1\text{ V to }3.5\text{ V}$; $T_{amb} = -40\text{ }^{\circ}\text{C to }+85\text{ }^{\circ}\text{C}$ (typical values measured at $T_{amb} = 25\text{ }^{\circ}\text{C}$); timings and levels refer to drawings and conditions illustrated in [Figure 89](#); unless otherwise specified.

Symbol	Parameter	Conditions	Min	Typ	Max	Unit
Crystal specification (X1)						
$T_{amb(X1)}$	ambient temperature		-40	-	+85	$^{\circ}\text{C}$
C_L	load capacitance		8	-	-	pF
R_s	series resonance resistor		-	40	80	Ω
C_1	motional capacitance		-	$1.5 \pm 20\%$	-	fF
C_0	parallel capacitance		-	$4.3 \pm 20\%$	-	pF
Crystal oscillator for 24.576 MHz [6]						
$f_{xtal(nom)}$	nominal frequency		-	24.576	-	MHz
$\Delta f_{xtal(nom)}$	permissible nominal frequency deviation		-	-	$\pm 50 \times 10^{-6}$	
$\Delta f_{xtal(nom)(T)}$	permissible nominal frequency deviation with temperature		-	-	$\pm 20 \times 10^{-6}$	
Crystal specification (X1)						
$T_{amb(X1)}$	ambient temperature		-40	-	+85	$^{\circ}\text{C}$
C_L	load capacitance		8	-	-	pF
R_s	series resonance resistor		-	40	80	Ω
C_1	motional capacitance		-	$1.5 \pm 20\%$	-	fF
C_0	parallel capacitance		-	$3.5 \pm 20\%$	-	pF
Clock input timing (XCLK)						
T_{cy}	cycle time		31	-	45	ns
δ	duty factors for t_{LLCH}/t_{LLC}		40	50	60	%
t_r	rise time		-	-	5	ns
t_f	fall time		-	-	5	ns
Data and control signal input timing X port, related to XCLK input						
$t_{SU;DAT}$	input data setup time		10	-	-	ns
$t_{HD;DAT}$	input data hold time		6	-	-	ns
Clock output timing						
C_L	output load capacitance		15	-	50	pF
T_{cy}	cycle time		35	-	39	ns

Table 147: Characteristics...*continued*

$V_{DD} = 3.0\text{ V to }3.6\text{ V}$; $V_{DDA} = 3.1\text{ V to }3.5\text{ V}$; $T_{amb} = -40\text{ }^{\circ}\text{C to }+85\text{ }^{\circ}\text{C}$ (typical values measured at $T_{amb} = 25\text{ }^{\circ}\text{C}$); timings and levels refer to drawings and conditions illustrated in [Figure 89](#); unless otherwise specified.

Symbol	Parameter	Conditions	Min	Typ	Max	Unit
δ	duty factors for t_{XCLKH}/t_{XCLKL}		35	-	65	%
t_r	rise time	0.6 V to 2.6 V	-	-	5	ns
t_f	fall time	2.6 V to 0.6 V	-	-	5	ns
Data and control signal output timing X port, related to XCLK output (for XPCK[1:0]83h[5:4] = 00 is default) [5]						
C_L	output load capacitance		15	-	50	pF
$t_{OHD;DAT}$	output data hold time	$C_L = 15\text{ pF}$	4	-	-	ns
t_{PD}	propagation delay from positive edge of XCLK output	$C_L = 15\text{ pF}$	-	-	19	ns
Control signal output timing RT port, related to LLC output						
C_L	output load capacitance		15	-	50	pF
$t_{OHD;DAT}$	output hold time	$C_L = 15\text{ pF}$	4	-	-	ns
t_{PD}	propagation delay from positive edge of LLC output	$C_L = 15\text{ pF}$	-	-	19	ns
ICLK output timing						
C_L	output load capacitance		15	-	50	pF
T_{cy}	cycle time		31	-	45	ns
δ	duty factors for t_{ICLKH}/t_{ICLKL}		35	-	65	%
t_r	rise time	0.6 V to 2.6 V	-	-	5	ns
t_f	fall time	2.6 V to 0.6 V	-	-	5	ns
Data and control signal output timing I port, related to ICLK output (for IPCK[1:0] 87h[5:4] = 00 is default)						
C_L	output load capacitance at all outputs		15	-	50	pF
$t_{OHD;DAT}$	output data hold time	$C_L = 15\text{ pF}$	4	-	-	ns
$t_{o(d)}$	output delay time	$C_L = 15\text{ pF}$	-	-	19	ns
ICLK input timing						
T_{cy}	cycle time		31	-	100	ns

[1] 8-bit image port output mode, expansion port is 3-stated.

[2] ADC1 is not taken into account, since component video is always converted by ADC2, ADC3 and ADC4.

[3] $V_{DD(I2C)}$ is the supply voltage of the I²C-bus. For $V_{DD(I2C)} = 3.3\text{ V}$ then $V_{IL(SCL,SDA)(max)} = 1\text{ V}$; for $V_{DD(I2C)} = 5\text{ V}$ then $V_{IL(SCL,SDA)(max)} = 1.5\text{ V}$. For $V_{DD(I2C)} = 3.3\text{ V}$ then $V_{IH(SCL,SDA)(min)} = 2.3\text{ V}$; for $V_{DD(I2C)} = 5\text{ V}$ then $V_{IH(SCL,SDA)(min)} = 3.5\text{ V}$.

[4] The levels must be measured with load circuits; 1.2 k Ω at 3 V (TTL load); $C_L = 50\text{ pF}$.

[5] The effects of rise and fall times are included in the calculation of $t_{OHD;DAT}$ and t_{PD} . Timings and levels refer to drawings and conditions illustrated in [Figure 89](#).

[6] The crystal oscillator drive level is typical 0.28 mW.

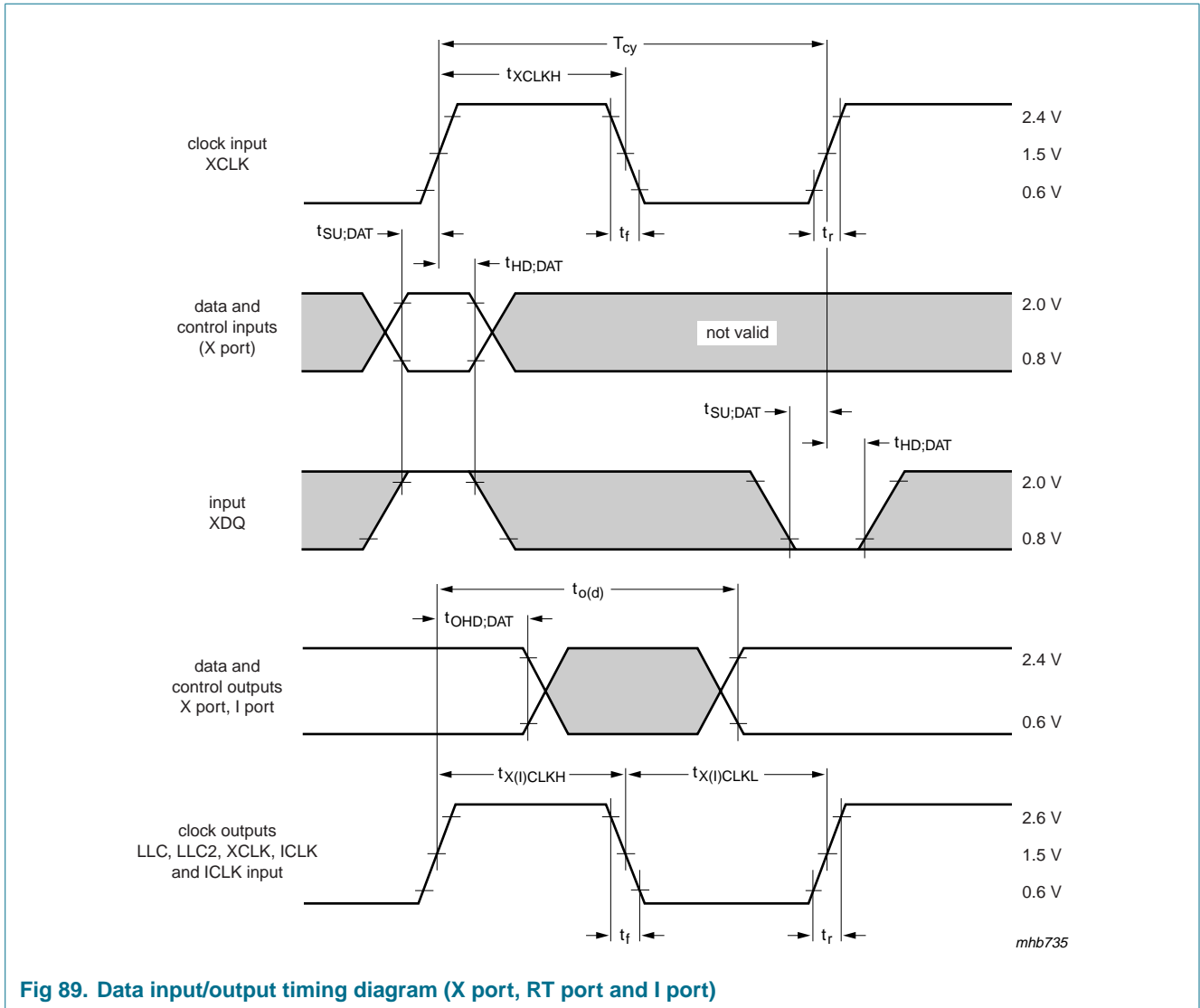
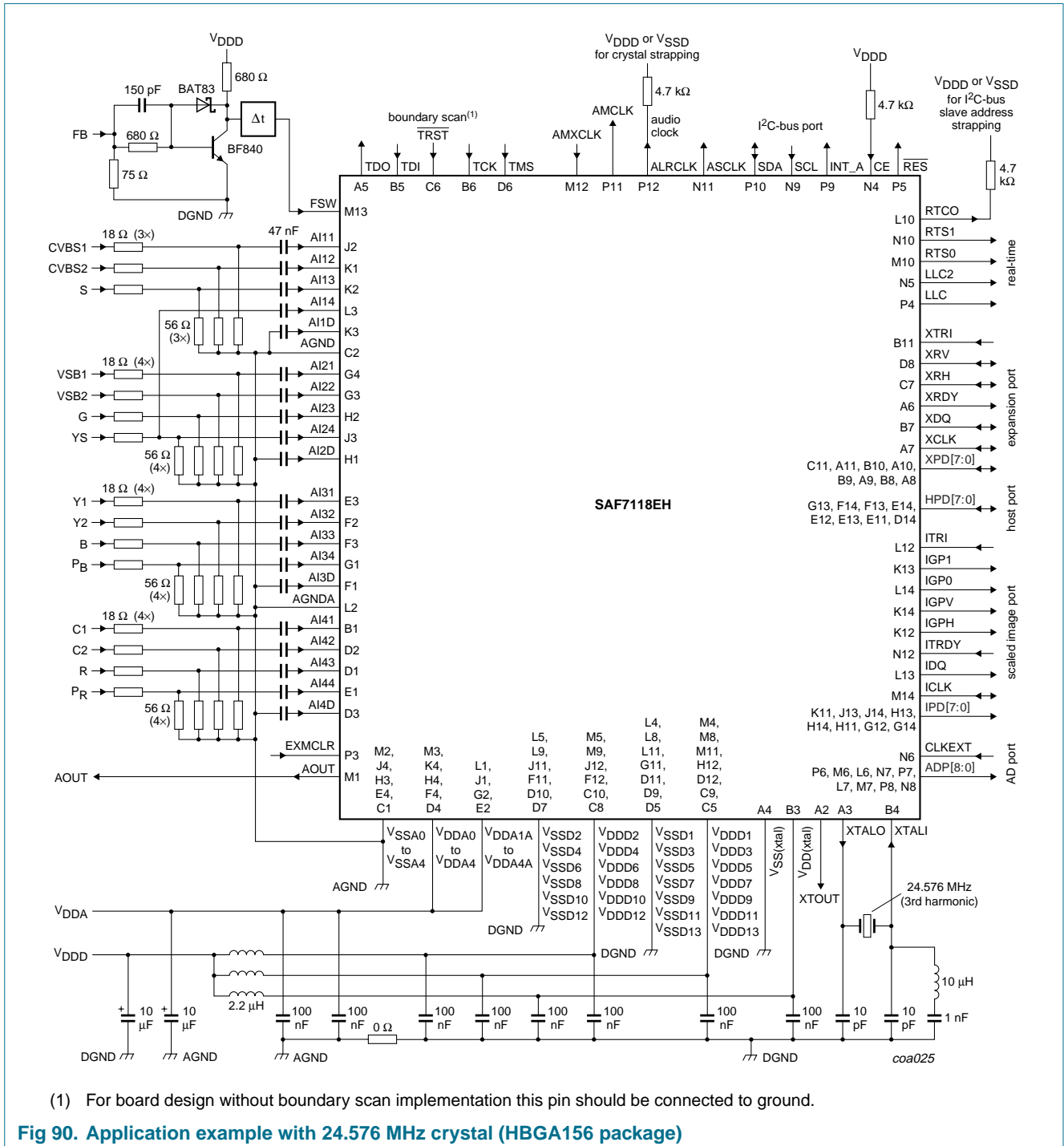
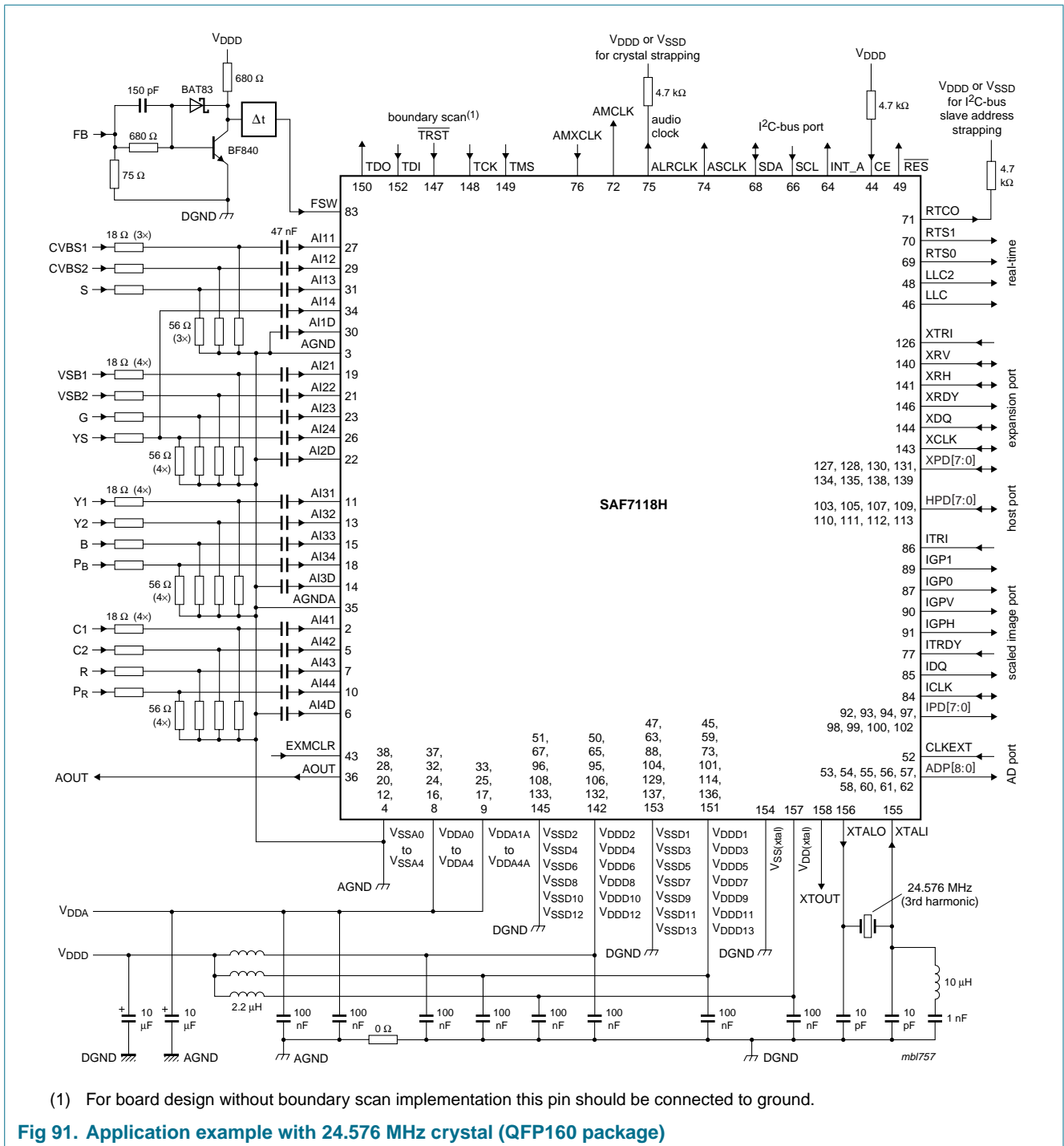
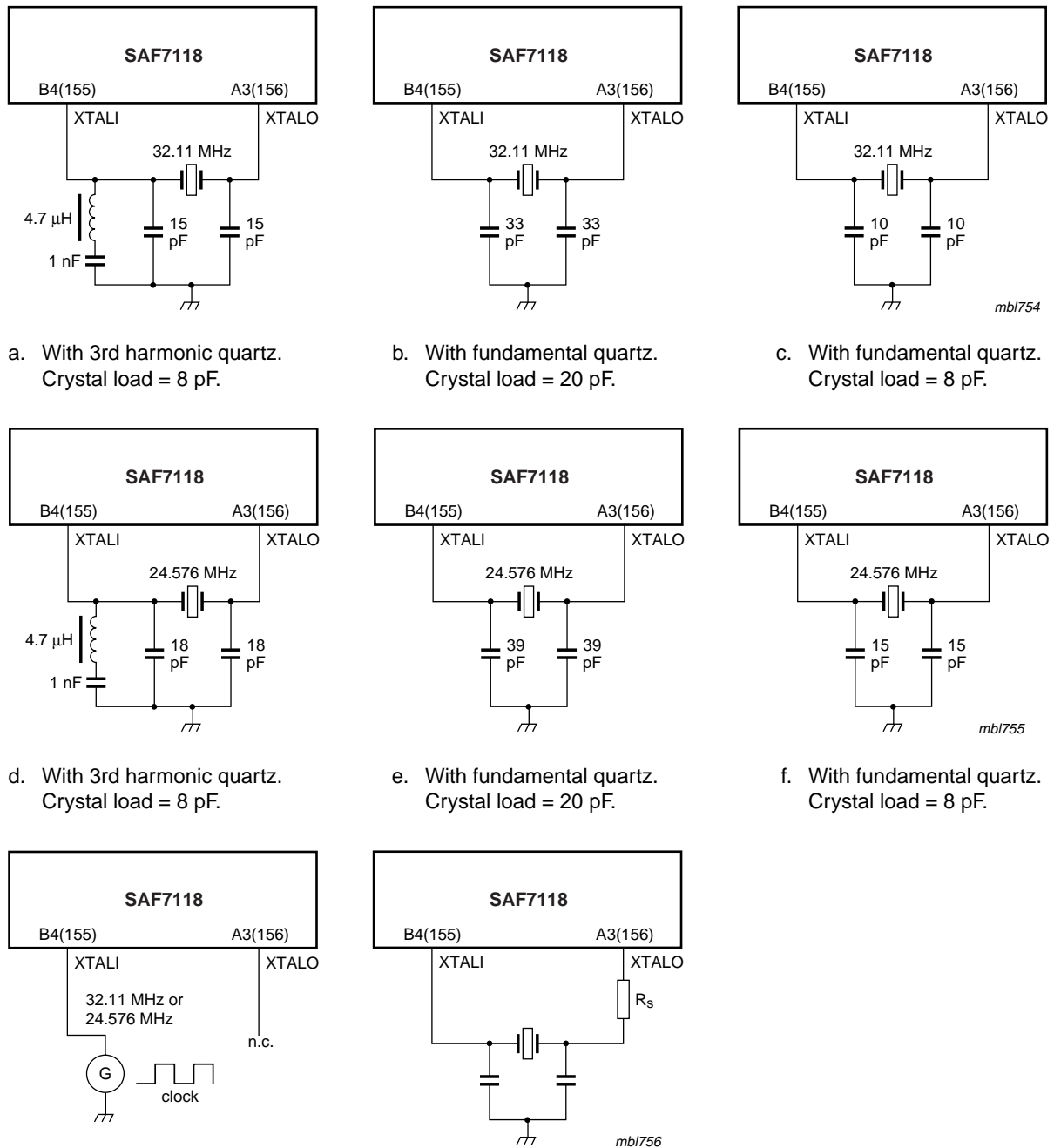

Fig 89. Data input/output timing diagram (X port, RT port and I port)

15. Application information







a. With 3rd harmonic quartz.
Crystal load = 8 pF.

b. With fundamental quartz.
Crystal load = 20 pF.

c. With fundamental quartz.
Crystal load = 8 pF.

d. With 3rd harmonic quartz.
Crystal load = 8 pF.

e. With fundamental quartz.
Crystal load = 20 pF.

f. With fundamental quartz.
Crystal load = 8 pF.

g. With direct clock.

h. With fundamental quartz and restricted drive level. When P_{drive} of the internal oscillator is too high a resistance R_s can be placed in series with the output of the oscillator XTALO.

Note: The decreased crystal amplitude results in a lower drive level but on the other hand the jitter performance will decrease.

Fig 92. Oscillator application (pin numbers for QFP160 in parenthesis)

16. Test information

16.1 Boundary scan test

The SAF7118 has built-in logic and 5 dedicated pins to support boundary scan testing which allows board testing without special hardware (nails). The SAF7118 follows the “*IEEE Std. 1149.1 - Standard Test Access Port and Boundary-Scan Architecture*” set by the Joint Test Action Group (JTAG) chaired by Philips.

The 5 special pins are Test Mode Select (TMS), Test Clock (TCK), Test Reset ($\overline{\text{TRST}}$), Test Data Input (TDI) and Test Data Output (TDO).

The Boundary Scan Test (BST) functions BYPASS, EXTEST, SAMPLE, CLAMP and IDCODE are all supported; see [Table 148](#). Details about the JTAG BST-TEST can be found in specification “*IEEE Std. 1149.1*”. A file containing the detailed Boundary Scan Description Language (BSDL) description of the SAF7118 is available on request.

Table 148: BST instructions supported by the SAF7118

Instruction	Description
BYPASS	This mandatory instruction provides a minimum length serial path (1 bit) between TDI and TDO when no test operation of the component is required.
EXTEST	This mandatory instruction allows testing of off-chip circuitry and board level interconnections.
SAMPLE	This mandatory instruction can be used to take a sample of the inputs during normal operation of the component. It can also be used to preload data values into the latched outputs of the boundary scan register.
CLAMP	This optional instruction is useful for testing when not all ICs have BST. This instruction addresses the bypass register while the boundary scan register is in external test mode.
IDCODE	This optional instruction will provide information on the components manufacturer, part number and version number.

16.1.1 Initialization of boundary scan circuit

The Test Access Port (TAP) controller of an IC should be in the reset state (TEST_LOGIC_RESET) when the IC is in functional mode. This reset state also forces the instruction register into a functional instruction such as IDCODE or BYPASS.

To solve the power-up reset, the standard specifies that the TAP controller will be forced asynchronously to the TEST_LOGIC_RESET state by setting the $\overline{\text{TRST}}$ pin LOW.

16.1.2 Device identification codes

A device identification register is specified in “*IEEE Std. 1149.1b-1994*”. It is a 32-bit register which contains fields for the specification of the IC manufacturer, the IC part number and the IC version number. Its biggest advantage is the possibility to check for the correct ICs mounted after production and determination of the version number of ICs during field service.

When the IDCODE instruction is loaded into the BST instruction register, the identification register will be connected between pins TDI and TDO of the IC. The identification register will load a component specific code during the CAPTURE_DATA_REGISTER state of the TAP controller and this code can subsequently be shifted out. At board level this code can be used to verify component manufacturer, type and version number. The device identification register contains 32 bits, numbered 31 to 0, where bit D31 is the most significant bit (nearest to TDI) and bit D0 is the least significant bit (nearest to TDO); see [Figure 93](#).

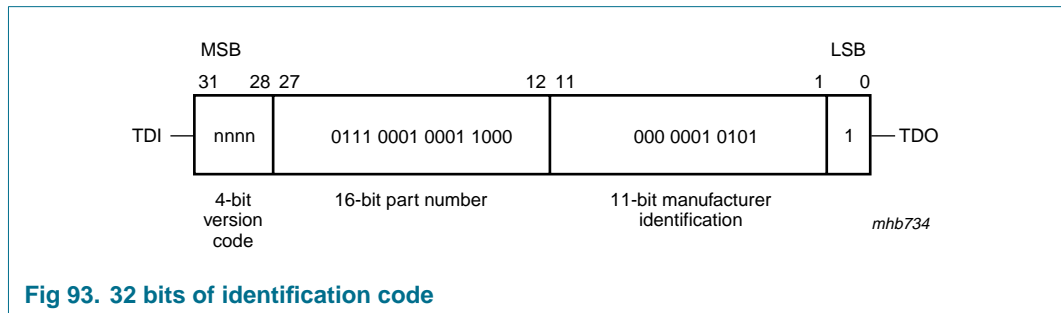

17. Package outline

HBGA156: plastic thermal enhanced ball grid array package; 156 balls;
body 15 x 15 x 1.15 mm; heatsink

SOT807-1

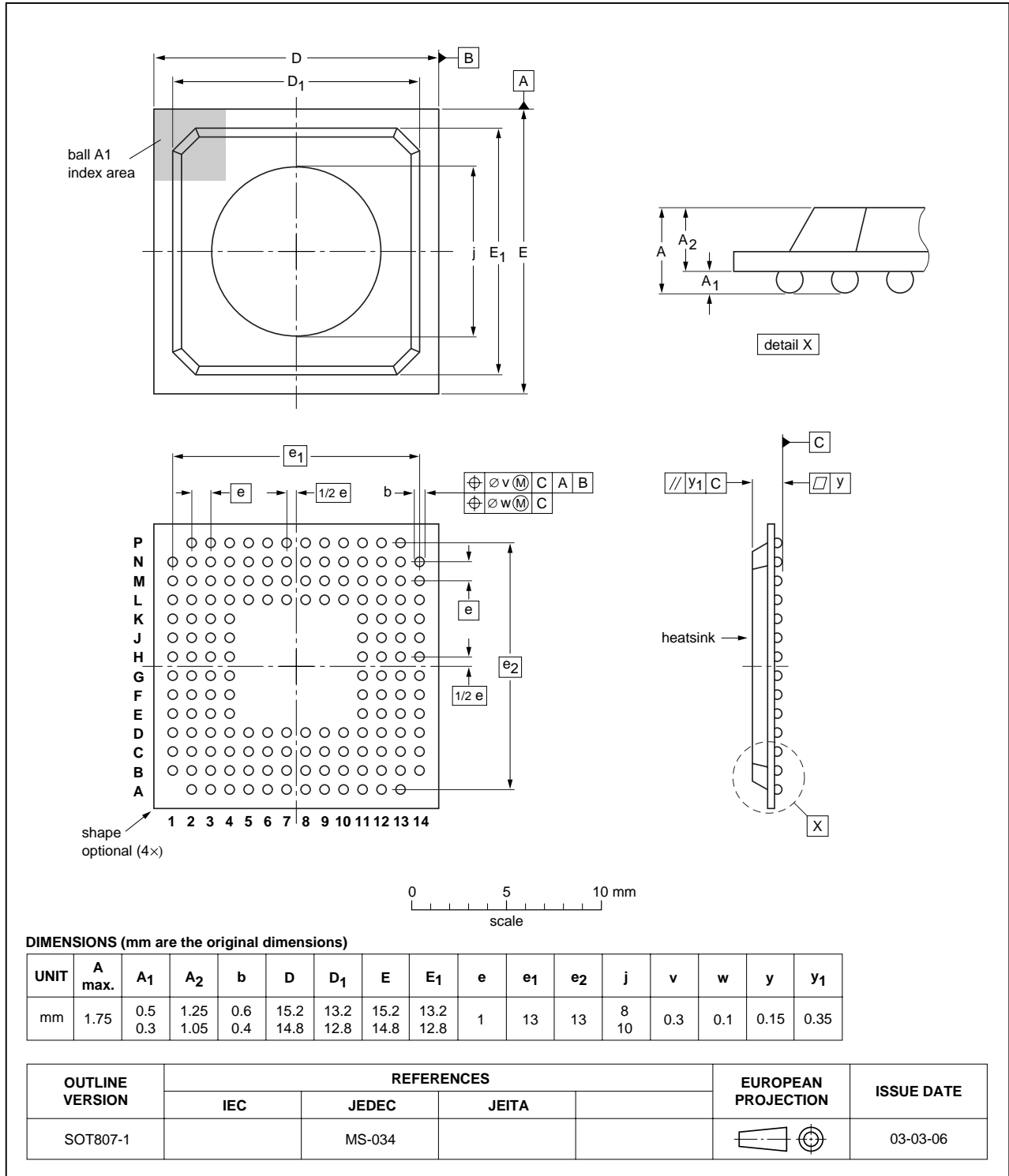

Fig 94. Package outline SOT807-1 (HBGA156)

QFP160: plastic quad flat package;
160 leads (lead length 1.6 mm); body 28 x 28 x 3.4 mm; high stand-off height

SOT322-2

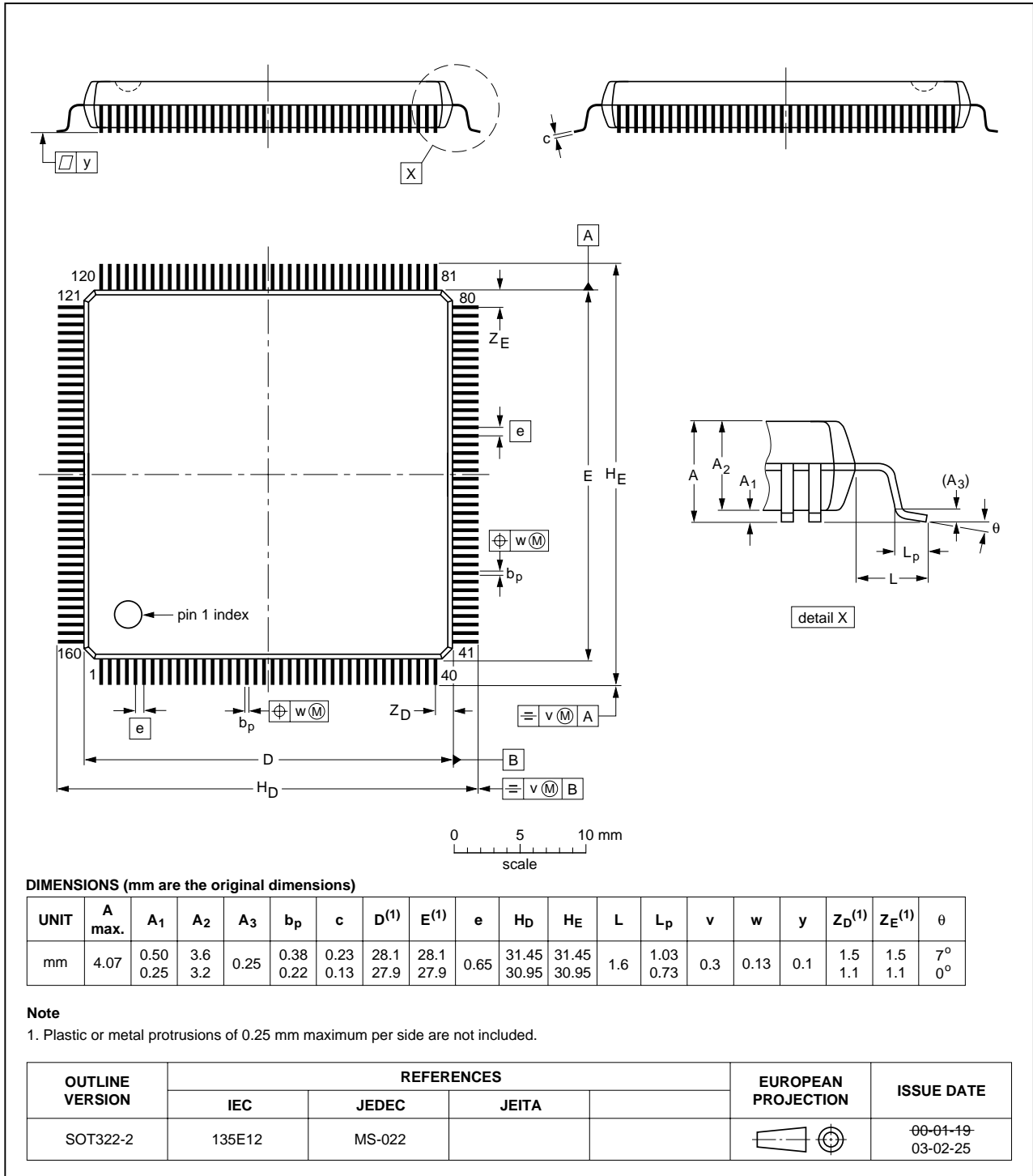

Fig 95. Package outline SOT322-2 (QFP160)

18. Soldering

18.1 Introduction to soldering surface mount packages

This text gives a very brief insight to a complex technology. A more in-depth account of soldering ICs can be found in our *Data Handbook IC26; Integrated Circuit Packages* (document order number 9398 652 90011).

There is no soldering method that is ideal for all surface mount IC packages. Wave soldering can still be used for certain surface mount ICs, but it is not suitable for fine pitch SMDs. In these situations reflow soldering is recommended.

18.2 Reflow soldering

Reflow soldering requires solder paste (a suspension of fine solder particles, flux and binding agent) to be applied to the printed-circuit board by screen printing, stencilling or pressure-syringe dispensing before package placement. Driven by legislation and environmental forces the worldwide use of lead-free solder pastes is increasing.

Several methods exist for reflowing; for example, convection or convection/infrared heating in a conveyor type oven. Throughput times (preheating, soldering and cooling) vary between 100 seconds and 200 seconds depending on heating method.

Typical reflow peak temperatures range from 215 °C to 270 °C depending on solder paste material. The top-surface temperature of the packages should preferably be kept:

- below 225 °C (SnPb process) or below 245 °C (Pb-free process)
 - for all BGA, HTSSON..T and SSOP..T packages
 - for packages with a thickness ≥ 2.5 mm
 - for packages with a thickness < 2.5 mm and a volume ≥ 350 mm³ so called thick/large packages.
- below 240 °C (SnPb process) or below 260 °C (Pb-free process) for packages with a thickness < 2.5 mm and a volume < 350 mm³ so called small/thin packages.

Moisture sensitivity precautions, as indicated on packing, must be respected at all times.

18.3 Wave soldering

Conventional single wave soldering is not recommended for surface mount devices (SMDs) or printed-circuit boards with a high component density, as solder bridging and non-wetting can present major problems.

To overcome these problems the double-wave soldering method was specifically developed.

If wave soldering is used the following conditions must be observed for optimal results:

- Use a double-wave soldering method comprising a turbulent wave with high upward pressure followed by a smooth laminar wave.
- For packages with leads on two sides and a pitch (e):
 - larger than or equal to 1.27 mm, the footprint longitudinal axis is **preferred** to be parallel to the transport direction of the printed-circuit board;

- smaller than 1.27 mm, the footprint longitudinal axis **must** be parallel to the transport direction of the printed-circuit board.

The footprint must incorporate solder thieves at the downstream end.

- For packages with leads on four sides, the footprint must be placed at a 45° angle to the transport direction of the printed-circuit board. The footprint must incorporate solder thieves downstream and at the side corners.

During placement and before soldering, the package must be fixed with a droplet of adhesive. The adhesive can be applied by screen printing, pin transfer or syringe dispensing. The package can be soldered after the adhesive is cured.

Typical dwell time of the leads in the wave ranges from 3 seconds to 4 seconds at 250 °C or 265 °C, depending on solder material applied, SnPb or Pb-free respectively.

A mildly-activated flux will eliminate the need for removal of corrosive residues in most applications.

18.4 Manual soldering

Fix the component by first soldering two diagonally-opposite end leads. Use a low voltage (24 V or less) soldering iron applied to the flat part of the lead. Contact time must be limited to 10 seconds at up to 300 °C.

When using a dedicated tool, all other leads can be soldered in one operation within 2 seconds to 5 seconds between 270 °C and 320 °C.

18.5 Package related soldering information

Table 149: Suitability of surface mount IC packages for wave and reflow soldering methods

Package [1]	Soldering method	
	Wave	Reflow [2]
BGA, HTSSON..T [3], LBGA, LFBGA, SQFP, SSOP..T [3], TFBGA, VFBGA, XSON	not suitable	suitable
DHVQFN, HBCC, HBGA, HLQFP, HSO, HSOP, HSQFP, HSSON, HTQFP, HTSSOP, HVQFN, HVSON, SMS	not suitable [4]	suitable
PLCC [5], SO, SOJ	suitable	suitable
LQFP, QFP, TQFP	not recommended [5] [6]	suitable
SSOP, TSSOP, VSO, VSSOP	not recommended [7]	suitable
CWQCCN..L [8], PMFP [9], WQCCN..L [8]	not suitable	not suitable

[1] For more detailed information on the BGA packages refer to the (LF)BGA Application Note (AN01026); order a copy from your Philips Semiconductors sales office.

[2] All surface mount (SMD) packages are moisture sensitive. Depending upon the moisture content, the maximum temperature (with respect to time) and body size of the package, there is a risk that internal or external package cracks may occur due to vaporization of the moisture in them (the so called popcorn effect). For details, refer to the Drypack information in the Data Handbook IC26; Integrated Circuit Packages; Section: Packing Methods.

[3] These transparent plastic packages are extremely sensitive to reflow soldering conditions and must on no account be processed through more than one soldering cycle or subjected to infrared reflow soldering with peak temperature exceeding 217 °C ± 10 °C measured in the atmosphere of the reflow oven. The package body peak temperature must be kept as low as possible.

- [4] These packages are not suitable for wave soldering. On versions with the heatsink on the bottom side, the solder cannot penetrate between the printed-circuit board and the heatsink. On versions with the heatsink on the top side, the solder might be deposited on the heatsink surface.
- [5] If wave soldering is considered, then the package must be placed at a 45° angle to the solder wave direction. The package footprint must incorporate solder thieves downstream and at the side corners.
- [6] Wave soldering is suitable for LQFP, QFP and TQFP packages with a pitch (e) larger than 0.8 mm; it is definitely not suitable for packages with a pitch (e) equal to or smaller than 0.65 mm.
- [7] Wave soldering is suitable for SSOP, TSSOP, VSO and VSSOP packages with a pitch (e) equal to or larger than 0.65 mm; it is definitely not suitable for packages with a pitch (e) equal to or smaller than 0.5 mm.
- [8] Image sensor packages in principle should not be soldered. They are mounted in sockets or delivered pre-mounted on flex foil. However, the image sensor package can be mounted by the client on a flex foil by using a hot bar soldering process. The appropriate soldering profile can be provided on request.
- [9] Hot bar soldering or manual soldering is suitable for PMFP packages.

19. Revision history

Table 150: Revision history

Document ID	Release date	Data sheet status	Change notice	Doc. number	Supersedes
SAF7118_3	20060216	Product data sheet	-	-	SAF7118_2
Modifications:					
			<ul style="list-style-type: none">• The format of this data sheet has been redesigned to comply with the new presentation and information standard of Philips Semiconductors• Table 4: pin AI3D corrected from I/O to I• Table 4: pin SCL corrected from I to I(/O)		
SAF7118_2	20040722	Product specification	-	9397 750 13496	SAF7118H_1
SAF7118H_1	20030103	Product specification	-	9397 750 10473	-

20. Data sheet status

Level	Data sheet status ^[1]	Product status ^{[2] [3]}	Definition
I	Objective data	Development	This data sheet contains data from the objective specification for product development. Philips Semiconductors reserves the right to change the specification in any manner without notice.
II	Preliminary data	Qualification	This data sheet contains data from the preliminary specification. Supplementary data will be published at a later date. Philips Semiconductors reserves the right to change the specification without notice, in order to improve the design and supply the best possible product.
III	Product data	Production	This data sheet contains data from the product specification. Philips Semiconductors reserves the right to make changes at any time in order to improve the design, manufacturing and supply. Relevant changes will be communicated via a Customer Product/Process Change Notification (CPCN).

[1] Please consult the most recently issued data sheet before initiating or completing a design.

[2] The product status of the device(s) described in this data sheet may have changed since this data sheet was published. The latest information is available on the Internet at URL <http://www.semiconductors.philips.com>.

[3] For data sheets describing multiple type numbers, the highest-level product status determines the data sheet status.

21. Definitions

Short-form specification — The data in a short-form specification is extracted from a full data sheet with the same type number and title. For detailed information see the relevant data sheet or data handbook.

Limiting values definition — Limiting values given are in accordance with the Absolute Maximum Rating System (IEC 60134). Stress above one or more of the limiting values may cause permanent damage to the device. These are stress ratings only and operation of the device at these or at any other conditions above those given in the Characteristics sections of the specification is not implied. Exposure to limiting values for extended periods may affect device reliability.

Application information — Applications that are described herein for any of these products are for illustrative purposes only. Philips Semiconductors makes no representation or warranty that such applications will be suitable for the specified use without further testing or modification.

22. Disclaimers

Life support — These products are not designed for use in life support appliances, devices, or systems where malfunction of these products can reasonably be expected to result in personal injury. Philips Semiconductors

24. Contact information

For additional information, please visit: <http://www.semiconductors.philips.com>

For sales office addresses, send an email to: sales.addresses@www.semiconductors.philips.com

customers using or selling these products for use in such applications do so at their own risk and agree to fully indemnify Philips Semiconductors for any damages resulting from such application.

Right to make changes — Philips Semiconductors reserves the right to make changes in the products - including circuits, standard cells, and/or software - described or contained herein in order to improve design and/or performance. When the product is in full production (status 'Production'), relevant changes will be communicated via a Customer Product/Process Change Notification (CPCN). Philips Semiconductors assumes no responsibility or liability for the use of any of these products, conveys no license or title under any patent, copyright, or mask work right to these products, and makes no representations or warranties that these products are free from patent, copyright, or mask work right infringement, unless otherwise specified.

23. Trademarks

Notice — All referenced brands, product names, service names and trademarks are the property of their respective owners.

I²C-bus — logo is a trademark of Koninklijke Philips Electronics N.V.

25. Contents

1	General description	1	8.4.2.2	Horizontal fine scaling (variable phase delay filter; subaddresses A8h to AFh and D8h to DFh)	55
2	Features	2	8.4.3	Vertical scaling	56
2.1	Video acquisition/clock	2	8.4.3.1	Line FIFO buffer (subaddresses 91h, B4h and C1h, E4h)	56
2.2	Video decoder	2	8.4.3.2	Vertical scaler (subaddresses B0h to BFh and E0h to EFh)	57
2.3	Component video processing	3	8.4.3.3	Use of the vertical phase offsets	58
2.4	Video scaler	3	8.5	VBI data decoder and capture (subaddresses 40h to 7Fh)	61
2.5	VBI data decoder and slicer	3	8.6	Image port output formatter (subaddresses 84h to 87h)	62
2.6	Audio clock generation	3	8.6.1	Scaler output formatter (subaddresses 93h and C3h)	63
2.7	Digital I/O interfaces	3	8.6.2	Video FIFO (subaddress 86h)	63
2.8	Miscellaneous	4	8.6.3	Text FIFO	64
3	Applications	4	8.6.4	Video and text arbitration (subaddress 86h)	64
4	Quick reference data	5	8.6.5	Data stream coding and reference signal generation (subaddresses 84h, 85h and 93h)	65
5	Ordering information	5	8.7	Audio clock generation (subaddresses 30h to 3Fh)	67
6	Block diagram	6	8.7.1	Master audio clock	68
7	Pinning information	7	8.7.2	Signals ASCLK and ALRCLK	69
7.1	Pinning	7	8.7.3	Other control signals	69
7.2	Pin description	8	9	Input/output interfaces and ports	70
8	Functional description	16	9.1	Analog terminals	70
8.1	Decoder	16	9.2	Audio clock signals	71
8.1.1	Analog input processing	16	9.3	Clock and real-time synchronization signals	71
8.1.1.1	Clamping	17	9.4	Interrupt handling	72
8.1.1.2	Gain control	18	9.4.1	Interrupt flags	72
8.1.2	Chrominance and luminance processing	21	9.4.1.1	Power state	72
8.1.2.1	Chrominance path	22	9.4.1.2	Video decoder	72
8.1.2.2	Luminance path	26	9.4.1.3	VBI data slicer	73
8.1.2.3	Brightness Contrast Saturation (BCS) control and decoder output levels	32	9.4.1.4	Scaler	73
8.1.3	Synchronization	33	9.4.2	Status reading conditions	73
8.1.4	Clock generation circuit	33	9.4.3	Erasing conditions	73
8.1.5	Power-on reset and CE input	34	9.5	Video expansion port (X port)	73
8.2	Component video processing	36	9.5.1	X port configured as output	74
8.2.1	RGB-to-(Y-C _B -C _R) matrix	36	9.5.2	X port configured as input	77
8.2.2	Downformatter	36	9.6	Image port (I port)	77
8.2.3	Component video BCS control	38	9.7	Host port for 16-bit extension of video data I/O (H port)	79
8.3	Decoder output formatter	39	9.8	Basic input and output timing diagrams I port and X port	80
8.4	Scaler	44	9.8.1	I port output timing	80
8.4.1	Acquisition control and task handling (subaddresses 80h, 90h, 91h, 94h to 9Fh and C4h to CFh)	46	9.8.2	X port input timing	80
8.4.1.1	Input field processing	47	10	I²C-bus description	83
8.4.1.2	Task handling	48			
8.4.1.3	Output field processing	49			
8.4.2	Horizontal scaling	51			
8.4.2.1	Horizontal prescaler (subaddresses A0h to A7h and D0h to D7h)	51			

continued >>

10.1	I ² C-bus format	83	10.6.2	Subaddresses 41h to 57h	125
10.2	I ² C-bus details	92	10.6.3	Subaddress 58h	125
10.2.1	Subaddress 00h	92	10.6.4	Subaddress 59h	126
10.2.2	Subaddress 01h	92	10.6.5	Subaddress 5Ah	126
10.2.3	Subaddress 02h	93	10.6.6	Subaddress 5Bh	126
10.2.4	Subaddress 03h	107	10.6.7	Subaddress 5Dh	126
10.2.5	Subaddress 04h	108	10.6.8	Subaddress 5Eh	126
10.2.6	Subaddress 05h	108	10.6.9	Subaddress 60h	127
10.2.7	Subaddress 06h	108	10.6.10	Subaddresses 61h and 62h	127
10.2.8	Subaddress 07h	109	10.7	Programming register interfaces and scaler part	127
10.2.9	Subaddress 08h	109	10.7.1	Subaddress 80h	127
10.2.10	Subaddress 09h	110	10.7.2	Subaddresses 83h to 87h	128
10.2.11	Subaddress 0Ah	110	10.7.3	Subaddress 88h	132
10.2.12	Subaddress 0Bh	111	10.7.4	Subaddress 8Fh	132
10.2.13	Subaddress 0Ch	111	10.7.5	Subaddresses 90h and C0h	133
10.2.14	Subaddress 0Dh	111	10.7.6	Subaddresses 91h to 93h	134
10.2.15	Subaddress 0Eh	111	10.7.7	Subaddresses 94h to 9Bh	136
10.2.16	Subaddress 0Fh	113	10.7.8	Subaddresses 9Ch to 9Fh	137
10.2.17	Subaddress 10h	113	10.7.9	Subaddresses A0h to A2h	138
10.2.18	Subaddress 11h	113	10.7.10	Subaddresses A4h to A6h	139
10.2.19	Subaddress 12h	114	10.7.11	Subaddresses A8h to AEh	140
10.2.20	Subaddress 13h	116	10.7.12	Subaddresses B0h to BFh	141
10.2.21	Subaddress 14h	117	11	Programming start setup	142
10.2.22	Subaddress 15h	117	11.1	Decoder part	142
10.2.23	Subaddress 16h	118	11.2	Component video part and interrupt mask	143
10.2.24	Subaddress 17h	118	11.3	Audio clock generation part	144
10.2.25	Subaddress 18h	119	11.4	Data slicer and data type control part	145
10.2.26	Subaddress 19h	119	11.5	Scaler and interfaces	146
10.2.27	Subaddress 1Eh	119	11.5.1	Trigger condition	146
10.2.28	Subaddress 1Fh	120	11.5.2	Maximum zoom factor	146
10.3	Programming register RGB/Y-P _B -P _R component input processing	120	11.5.3	Examples	147
10.3.1	Subaddress 23h	120	12	Limiting values	149
10.3.2	Subaddress 24h	121	13	Thermal characteristics	149
10.3.3	Subaddress 25h	121	14	Characteristics	150
10.3.4	Subaddress 29h	121	15	Application information	156
10.3.5	Subaddress 2Ah	122	16	Test information	159
10.3.6	Subaddress 2Bh	122	16.1	Boundary scan test	159
10.3.7	Subaddress 2Ch	122	16.1.1	Initialization of boundary scan circuit	159
10.4	Interrupt mask registers	123	16.1.2	Device identification codes	159
10.4.1	Subaddress 2Dh	123	17	Package outline	161
10.4.2	Subaddress 2Eh	123	18	Soldering	163
10.4.3	Subaddress 2Fh	123	18.1	Introduction to soldering surface mount packages	163
10.5	Programming register audio clock generation	124	18.2	Reflow soldering	163
10.5.1	Subaddresses 30h to 32h	124	18.3	Wave soldering	163
10.5.2	Subaddresses 34h to 36h	124	18.4	Manual soldering	164
10.5.3	Subaddress 38h	124	18.5	Package related soldering information	164
10.5.4	Subaddress 39h	124	19	Revision history	166
10.5.5	Subaddress 3Ah	124			
10.6	Programming register VBI data slicer	125			
10.6.1	Subaddress 40h	125			

continued >>

20	Data sheet status	167
21	Definitions	167
22	Disclaimers	167
23	Trademarks	167
24	Contact information	167



© Koninklijke Philips Electronics N.V. 2006

All rights are reserved. Reproduction in whole or in part is prohibited without the prior written consent of the copyright owner. The information presented in this document does not form part of any quotation or contract, is believed to be accurate and reliable and may be changed without notice. No liability will be accepted by the publisher for any consequence of its use. Publication thereof does not convey nor imply any license under patent- or other industrial or intellectual property rights.

Date of release: 16 February 2006
Document number: SAF7118_3

Published in The Netherlands